

LEAD INSPECTOR CERTIFICATION TRAINING

U.S. ENVIRONMENTAL PROTECTION AGENCY
ACCREDITED LEAD TRAINING PROVIDER

STUDENT MANUAL



ENVIRONMENTAL EDUCATION ASSOCIATES
888 4 ENV EDU *environmentaleducation.com*

**INSPECTING FOR LEAD-BASED PAINT
STUDENT MANUAL**

EPA MODEL LEAD-BASED PAINT INSPECTOR CURRICULUM

**Produced under cooperative agreement (#CE-823710)
between the Georgia Tech Research Institute and the
U.S. Environmental Protection Agency
Office of Prevention, Pesticides and Toxic Substances**

May 2000 edition

EPA Project Officer—Georgene Cooper
Office of Prevention, Pesticides and Toxics
U.S. Environmental Protection Agency
Washington, DC 20460

Georgia Tech Research Institute
Safety, Health and Environmental Technology Division
151 6th Street, O'Keefe Building
Atlanta, Georgia 30332-0837
404-894-3806
Fax 404-894-8275

Material contained in this publication is in the public domain.

It may be reproduced without permission of the federal government. Information contained in this curriculum may be reprinted in full or in part, or freely quoted, if this page is included as a means of crediting resources. This manual is not intended as an interpretation of EPA or OSHA regulations.

Acknowledgements

Georgia Tech Research Institute would like to acknowledge the principal author of the first edition of this model curriculum: David Cox of Quantech, Inc.

This revised edition was prepared by the staff of the Safety, Health and Environmental Technology Division of the Georgia Tech Research Institute:

Project Director

Vicki Hanrahan Ainslie

Student Manual

Vicki Hanrahan Ainslie

Myrtle I. Turner

Eliesh O'Neil Lane

Contributing Authors:

Salvatore Cali, Stellar Environmental, Inc.

John Pesce, Niton Corporation

Instructor Manual and Visual Aids

Vicki Hanrahan Ainslie

Myrtle I. Turner

Sheree Collins

Eliesh O'Neil Lane

Additional art work for this edition:

Sheree Collins

Vicki Hanrahan Ainslie

Layout and copy editing by:

Vicki Hanrahan Ainslie

Dara O'Neil

Rae Adams

Lydia Griffin

Leigh Fitzpatrick

Nancy Davis

Peer Reviewers

We wish to thank the following peer reviewers for their expertise and significant comments:

Richard Baker, Baker Environmental Consulting, Inc.

Scott Balfour, LeadTest, Inc.

Scott Clark, University of Cincinnati

Lorne Garrettson, Emory University/Georgia Poison Control Center

Charles Gilbert, Consultant

Judy Jarrell, University of Cincinnati

Bill Menrath, University of Cincinnati

Amy Mortimer, ICF Consulting

Andrea Rimer, Troutman Sanders LLP

Ron Short, Consultant

Ellen Tohn, Alliance to End Childhood Lead Poisoning

Johnathan Wilson, National Center for Lead-Safe Housing

John Zilka, Applied Systems, Inc.

The following peer reviewers deserve a special thank you for putting forth an extraordinary effort to ensure the high quality, accuracy, and completeness of this curriculum:

Salvatore Cali, Stellar Environmental, Inc.

John Pesce, Niton Corporation

Alex Fischburg, Applied Science, Inc.

David Jacobs, HUD

Warren Friedman, HUD

EPA Reviewers

Headquarters staff:

Ellie Clark, OPPT

Eckerson Dayton, OPPT

Mark Henshall, NPCD/LHMIB

Karen Hoffman, CCD

Ben Lim, NPCD/TB

Dan Reinhart, NPCD/TB

John Scalera, NPCD/TB

Brad Schultz, NPCD/TB

John Schwemberger, NPCD/TB

Dave Topping, NPCD/LHMIB

Darlene Watford, NPCD/TB

Mike Wilson, NPCD/NPCAB

EPA Regional Staff:

Jim Bryson, Region I

Jeff Robinson, Region VI

Mazzie Talley, Region VII

**Additionally, Georgia Tech would like to thank the following for their assistance
in the cooperative agreement as project officers:**

Karen Hoffman, CCD

Mark Henshall, NPCD/LHMIB

Georgene Cooper, NPCD/NPCAB

)

)

)

INSPECTING FOR LEAD-BASED PAINT

TABLE OF CONTENTS

<u>Title</u>	<u>Chapter</u>
Course Overview	1
Background Information for Lead Inspectors	2
Health Effects of Lead Exposure	3
Regulatory Background.....	4
Theory and Use of X-ray Fluorescence Analyzers	5
Liability and Insurance Issues	6
Lead-based Paint Testing Operations	7
Visual Inspection.....	8
Dust Sampling for Lead Contamination	9
Soil Sampling for Lead Contamination	10
Sample Analysis and Laboratory Accreditation	11
Field Trip.....	12
Data Evaluation and Report Preparation	13
Glossary.....	14



CHAPTER 1

COURSE OVERVIEW

Course Purpose 1-3

The Importance of Trained and Certified Inspectors 1-4

How Common Is Lead Pollution? 1-6

Title X 1-7

HUD *Guidelines* 1-9

Section 302 of the Lead-based Paint Poisoning Prevention Act (LBPPPA)..... 1-10

Abbreviations 1-11

Units of Measure 1-12



Inspecting for Lead-based Paint



Course Overview

Course Purpose

This course is designed to train inspectors to identify the presence of lead in housing in order to protect children, and focuses specifically on the presence of lead in paint (paint inspections) and in dust and soil (clearance inspections). The course is based in large part on two documents:¹

- *Guidelines for the Evaluation and Control of Lead-based Paint Hazards in Housing*, Department of Housing and Urban Development (HUD), 1995 (revised September 1997).
- *Lead; Requirements for Lead-based Paint Activities in Target Housing and Child-Occupied Facilities: Final Rule*, (40 CFR Part 745), U.S. Environmental Protection Agency (EPA), 29 August 1996.

This course is one of six model training courses. The other courses are for lead abatement supervisors, abatement project designers, risk assessors, abatement workers, and operations and maintenance workers. This intensive course's focus is primarily on inspecting for lead-based paint, although other sources of lead—such as lead-contaminated dust, soil, and water—are also discussed.

A major goal of this course is to train inspectors to identify lead-based paint (LBP) in housing. However, the basic principles of the course also apply to other buildings or structures painted with lead-based paint. Although testing dust, soil, and drinking water is not required as part of a lead-based paint inspection, these sources, examined in the risk assessment process, may also present lead exposure hazards in the residential setting. The risk assessment training is designed as a follow-on to this three-day curriculum. The lead inspector may, however, test soil and dust for lead contamination as part of a clearance inspection conducted after a lead hazard control activity is completed.

With the passage of the Residential Lead Hazard Reduction Act (Title X of the Community Development and Housing Act of 1992), the federal government began to focus on primary prevention of lead poisoning through identifying and reducing lead hazards. An important part of lead poisoning prevention, lead-based paint inspections

- focus attention on the sources of lead that could poison children; and
- reduce the cost of lead hazard control by identifying which surfaces are coated with lead-based paint.

¹Many lead-related publications can be obtained from HUD USER at 800-245-2691; the National Lead Information Center at 800-424-LEAD or via the internet at www.epa.gov/lead/nlic; EPA's home page at www.epa.gov/lead; and from HUD's home page at www.hud.gov/lea.



Inspectors identify the presence of lead-based paint in housing in order to protect children.

The focus of this course is inspecting for LBP.

The inspector also tests soil and dust for lead-contamination as part of a clearance inspection.



The Importance of Trained and Certified Inspectors

Trained and certified inspectors are essential to the lead-poisoning prevention effort. Certified lead inspectors

- identify the lead-based painted surfaces in housing;
- certify the results of an inspection in writing;
- conduct post-hazard control clearance sampling to determine if
 - the specified hazard control strategy was conducted
 - the area is safe for unprotected workers to enter
 - the area is a safe place for residents and young children to live.

An inspector must be

- knowledgeable about the performance and limitations of all lead-testing techniques and the methods to conduct them;
- familiar with all lead testing methods and sample collection techniques and standards;
- able to perform needed mathematical calculations;
- skilled in interpreting test results;
- capable of making objective decisions;
- able to implement and interpret quality control procedures.

An inspector must contact each state/Indian tribe before conducting inspections there.

EPA or state regulations (effective in all states in March 2000) *require* that all lead-based paint inspections conducted in target housing and child-occupied facilities must be performed by certified lead inspectors. Many states and Indian tribes have already implemented these regulations. Successful completion of this course is the first step in becoming a certified inspector. Additional steps include successful completion of a third party examination and applying either to the state, Indian tribe, or to EPA for certification in the regions of the country in which the inspector works. When in effect, new HUD regulations will require that virtually all paint testing carried out in HUD-associated housing be performed by certified lead inspectors or their equivalent.

Under section 404 of Title X (see the section on Title X on page 1-7), EPA has developed a model state program that provides a basis from which states and Indian nations can develop lead training, certification/licensing, and work-practices regulations. Before conducting a lead inspection, an inspector should contact each state or Indian nation in which he/she works to determine their requirements. (A listing of the states' and Indian tribes' lead certification programs in effect or in progress is included as an appendix in the Regulatory Background chapter [Chapter 4].) A few localities (i.e., cities or counties) have their

Course Overview

own requirements. The federal, state, and Indian tribe programs include specific work practices which must be followed when conducting lead-based paint activities.

Because lead inspection is a developing field and techniques are changing rapidly, lead certification regulations require inspectors to complete a refresher course and post-course examination at least every three years. Some states require annual or biannual refresher training. These refresher courses will help inspectors stay informed of new technologies, regulations, testing and sampling methods, and inspection procedures.

In late 1996, a regulation took effect that directly affects the need for trained and certified lead inspectors. The joint EPA/HUD Residential Lead-based Paint Disclosure rule (covered in more detail in Chapter 4) allows prospective purchasers of housing built before 1978 to have a lead-based paint inspection or risk assessment conducted to determine whether lead-based paint or lead-based paint hazards exist in the housing.



EPA requires refresher training every three years; however, some states and Indian tribes require training more frequently.

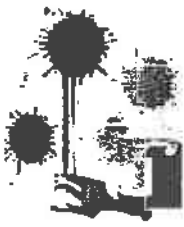

HUD estimates that 64 million housing units contain lead-based paint.

Lead-based paint is most common in pre-1950 housing.

Childhood lead poisoning remains a major environmental disease.

How Common Is Lead Pollution?

Our society faces many severe health and environmental problems as a result of lead pollution. Surveys have been conducted by HUD and EPA to better estimate the extent of lead-paint hazards in the nation's housing stock. These surveys found that lead-based paint, the major contributor to childhood lead poisoning, is widespread in housing built before 1980. Lead-based paint is present in roughly 83 percent of all housing stock in the private sector and in roughly 86 percent of family housing units in the nation's housing authorities.² HUD estimates that 64 million private housing units contain lead-based paint and that 20 million have lead-based paint hazards. About four million of those units have children under six living in them.

Lead-based paint is found more often in pre-1950 housing units, although housing constructed prior to 1978 may contain lead-based paint. It is found as often in the homes of the more affluent as in lower-income housing, and in both rural and urban housing. These findings are somewhat unexpected, because studies of blood-lead levels in children have found that elevated blood lead levels are more common among children of color from lower income families who live in urban areas. The higher blood lead levels among lower income children may result from

- worse physical condition and older age of the housing;
- more lead-contaminated dust in the housing;
- high lead levels in urban soil.

The high blood-lead levels may also stem from poorer nutrition of the children (which increases how much lead the body absorbs) and from greater exposure to lead in drinking water.

Childhood lead poisoning remains a major environmental disease, despite considerable progress in lead-hazard control. In the late 1970s, the Centers for Disease Control and Prevention (CDC) found that 4.5 million children had excessive levels of lead in their blood. Data from studies from 1988-91 indicated that number had dropped to 1.7 million; new data now show that between 1991-94, almost one million children had blood lead levels above CDC's level of concern (10 micrograms of lead/deciliter of whole blood—10 µg/dL). The major remaining source of exposure for these children is lead-based paint and the contaminated dust and soil it generates. (Units of measure used here and throughout this curriculum are defined on page 1-12 of this chapter and in the Glossary—Chapter 14.)

²*Report on the National Survey of Lead-based Paint in Housing, Base Report, EPA-747-R95-003, USEPA, April 1995.*

Course Overview



Title X

In 1992 Congress passed Title X—legislation that represented a new strategy to reduce lead hazards. This law affects how some federal agencies deal with lead-based paint and lead-based hazards. The Residential Lead-based Paint Hazard Reduction Act (Title X) of the Community Development and Housing Act of 1992 shifted the focus of federal legislation from acting only on existing lead-based paint hazards to preventing new hazards from occurring. The end of Chapter 4 in this manual contains a summary of the sections of Title X, the agencies responsible for implementing Title X, and the actions required. The HUD *Guidelines* are based on the requirements set forth by Section 1017 of Title X. The training and certification requirements implemented by EPA are based on requirements set forth by Section 402 of the Toxic Substances Control Act (TSCA). Section 404 of TSCA establishes the criteria by which state or tribal programs are authorized by EPA to administer and enforce the standards, regulations or other requirements established under TSCA sections 402 (training and certification) and 406 (lead hazard information pamphlet and renovation regulations). More discussion of Title X is included in Chapter 4 of this manual, including a complete listing of the sections of Title X and the agencies responsible for implementation.

Title X introduced key terms and definitions that have been incorporated into the regulations governing the lead-based paint detection and control industry. Some of these terms and their definitions include the following:

lead-based paint: paint, varnish, shellac, or other coating on surfaces that contain 1.0 mg/cm² or more of lead or 0.5 percent or more lead by weight;

lead-based paint hazards: any condition that causes exposure to lead-contaminated dust, lead-contaminated soil, or lead-contaminated paint that is deteriorated or present in accessible surfaces, friction surfaces, or impact surfaces that would result in adverse human health effects as identified by the EPA Administrator under TSCA section 403.³

lead-based paint inspection: a surface-by-surface investigation to determine the presence of lead-based paint. A report is then issued that identifies if there is lead-based paint present and where it is located.

Title X shifted the focus of federal legislation to preventing lead-based paint hazards from occurring.

**Lead-based paint:
≥ 1.0 mg/cm² or
≥ 0.5% by weight**

³ EPA has issued interim guidance on levels of lead in paint, dust, and soil and has issued proposed health-based standards for lead-based paint hazards, lead-contaminated soil and lead-contaminated dust. Until the final standards are issued, inspectors should follow the information in the interim guidance—*Guidance on Identification of Lead-based Paint Hazards*. Notice. *Federal Register*, pp 47248-47257, 11 September 1995.

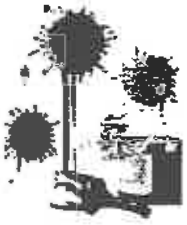

Deteriorated LBP is considered a hazard.

Inspecting for Lead-based Paint

deteriorated paint: any interior or exterior paint that is peeling, chipping, chalking, or cracking, or is located on an interior or exterior surface or fixture that is damaged or deteriorated;

accessible surface: surface that protrudes from the surrounding area to the extent that a child can chew the surface and is within three feet of the floor or ground (e.g., window sills, railing, and the edges of stair treads);

friction surface: an interior or exterior surface that is subject to abrasion or friction (e.g., certain window, floor, and stair surfaces);

impact surface: an interior or exterior surface that is subject to damage from repeated impacts (e.g., certain parts of door frames).

Course Overview

HUD Guidelines

Lead-based paint inspection is a critical first step in solving the lead problem in housing throughout the United States. While EPA and many states and Indian tribes have established training and certification requirements for lead-based paint inspectors, HUD has developed a protocol to follow when testing housing for lead-based paint. This protocol is included in the *HUD Guidelines*. These guidelines were designed to assist property owners, private contractors, and government agencies to reduce sharply children's exposure to lead without unduly disrupting the housing market and the nation's supply of affordable housing. The *Guidelines for the Evaluation and Control of Lead-based Paint Hazards in Housing* are detailed, technical, and comprehensive. The primary purpose of the *Guidelines* is to guide people involved in identifying and controlling lead-based paint hazards in housing. The *Guidelines* include a chapter with detailed steps for conducting a thorough lead-based paint inspection. A major portion of this three-day course is based the 1997 revision of that chapter.

The *Guidelines* include 17 additional chapters covering topics such as: risk assessment, deciding whether to abate, abatement methods, interim controls, worker protection, occupant protection, cleanup, clearance, waste disposal, and ongoing monitoring. The *Guidelines* can be used by state and local governments and the private sector as a source of standards and procedures for testing and abating lead-based paint in public and privately owned housing, day-care centers, and public buildings that exhibit conditions similar to those in residential structures.

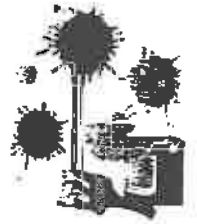

The HUD Guidelines are designed to assist in identifying and controlling lead-based paint hazards in housing.

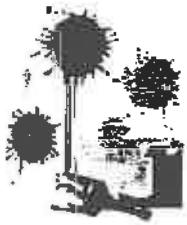

Section 302 of the Lead-based Paint Poisoning Prevention Act (LBPPPA)

Section 302 of the Lead-based Paint Poisoning Prevention Act (LBPPPA), as amended (1987, 1988), requires public housing authorities (PHAs) and Indian housing authorities (IHAs) to

- inspect all intact and non-intact interior and exterior painted surfaces in a random sample of dwellings and common areas in pre-1978 family developments;
- complete all inspections by 6 December 1994;
- abate lead-based paint equal to or greater than 1 milligram per square centimeter (1.0 mg/cm²) using the XRF analyzer or 0.5% (or 5000 parts per million) using laboratory analysis methods.

These amendments to the LBPPPA began an intensive period of lead-based paint inspections in public and Indian housing. Based on the data generated from these inspections, HUD was able to evaluate and refine the inspection process for incorporation into the 1995 HUD *Guidelines*. After two years of use, HUD again revised the inspection protocol in 1997. The paint testing portion of this course is based on this 1997 protocol.

There is no fixed date for abatement of lead-based paint in PHAs and IHAs. However, all lead-based paint must be abated when the housing is modernized.

On 15 September 1999 HUD published final regulations to implement sections 1012 and 1013 of Title X, which set forth specific policies on lead-based paint hazard reduction in federally assisted and federally owned housing (24 CFR Part 35—*Requirements for Notification, Evaluation and Reduction of Lead-based Paint Hazards in Housing Receiving Federal Assistance and Federally-owned Residential Property Being Sold*). This rule is a comprehensive amendment of previous federal housing lead-based paint regulations and consolidates the many dispersed HUD lead-based paint requirements into one part of the Code of Federal Regulations. More information on the requirements of this rule can be found in Chapter 4, *Regulatory Background*.

PHAs and IHAs must abate lead-based paint in pre-1978 family developments.

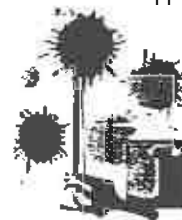

Course Overview

Abbreviations

There are many abbreviations and acronyms used throughout this manual. This reference guide serves as a reminder of what these abbreviations and acronyms mean. All of the abbreviations and acronyms on this page are defined in the glossary.

A2LA	American Association for Laboratory Accreditation
AAS	atomic absorption spectrometry
AIHA	American Industrial Hygiene Association
ASTM	American Society for Testing and Materials
ASV	anodic stripping voltametry
CDC	Centers for Disease Control and Prevention
CFR	Code of Federal Regulations
ELPAT	Environmental Laboratory Proficiency Analytical Testing
EPA	Environmental Protection Agency
HEPA	high efficiency particulate air
HUD	Department of Housing and Urban Development
ICP-AES	inductively coupled plasma atomic emission spectrometry
LBP	lead-based paint
MSDS	material safety data sheet
NIOSH	National Institute for Occupational Safety and Health
NIST	National Institute of Standards and Technology
NLLAP	National Lead Laboratory Accreditation Program
OSHA	Occupational Safety and Health Administration
PCS	performance characteristics sheet
Pb	The chemical symbol for lead
PEL	permissible exposure limit
poly	polyethylene sheet plastic
RCRA	Resource Conservation and Recovery Act
TCLP	toxic characteristic leaching procedure
TSP	trisodium phosphate
XRF	X-ray fluorescence
ZPP	zinc protoporphyrin



Units of Measure

These units will be explained and defined during this course.

cm	<i>centimeter</i> —1/100 of a meter; 0.3937 of an inch
cm ²	<i>square centimeter</i> —0.1550 square inch; unit of measure for lead in paint (mg/cm ²)
dL	<i>deciliter</i> —A <i>deciliter</i> (dL) is a measure of volume; the unit of measure for blood lead levels. The prefix “ <i>deci-</i> ” means “one-tenth.” One deciliter is roughly the same as about one-tenth of a quart, or about 3.4 fluid ounces. 1 dL = about 1/2 cup
ft	<i>foot</i> —12 inches; 30.48 centimeters
ft ²	<i>square foot</i> —144 square inches; 929 square centimeters; the unit of measure most often used for dust wipe samples (µg/ft ²).
m	<i>meter</i> —39.37 inches; 1.0936 yards
m ³	<i>cubic meter</i> —35.314 cubic feet; the unit of measure for lead in the air that workers breathe
g	<i>gram</i> —a measure of weight; 0.035 ounces
mg	<i>milligram</i> —1/1000 of a gram; unit of measure for lead in paint
µg	<i>microgram</i> —a measure of weight; used for lead levels in dust and soil; one millionth of a gram: µg; the prefix “ <i>micro-</i> ” means “1/1,000,000 of” (one millionth of)
ppm	<i>parts per million</i> — meaning the weight of one part per weight of the total amount of material; used when measuring lead in paint chips, water samples, and hazardous waste lead level results. For example, a lead concentration of 1 ppm expresses the ratio of one gram of lead dissolved into one million (1,000,000) grams of water. Therefore, one percent equals 10,000 ppm.; also, 0.6% equals 600 ppm.



Understanding Units

A *milligram* is a measure of weight. There are 1,000 milligrams in a gram. The abbreviation for milligram is *mg*.

A *centimeter* is one one-hundredth of a meter or 0.3937 of an inch. The square shown to the right represents one square centimeter (cm^2). Lead-based paint is defined as 1.0 milligram of lead per square centimeter of paint or coating.



A *microgram* is a measure of weight. There are 1 million micrograms in a gram. The abbreviation for microgram is μg . Since there are 453 grams in one pound and 16 ounces in one pound, one gram equals 0.035 ounces. A microgram is equal to about 35/1,000,000,000 (thirty-five billionths) of an ounce.



A penny weighs about two grams. Imagine cutting a penny into 2 million pieces. A microgram would weigh the same as one of those 2 million pieces.

A *deciliter* is a measure of volume. It is equal to a little less than half a cup. A person weighing 165 pounds has about 60 deciliters of blood. The abbreviation for deciliter is *dL*.



A *cubic meter* is a measure of volume.

Air measurements for lead are calculated in cubic meters. A cubic meter is a slightly larger volume than the cubic yard. A cubic meter is about the volume of a desk.





Inspecting for Lead-based Paint





CHAPTER 2

BACKGROUND INFORMATION FOR LEAD INSPECTORS

Objectives	2-3
Learning Tasks	2-4
History of Lead Use	2-5
Sources of Environmental Lead Contamination	2-8
Lead in Paint	2-9
Lead in Surface Dust and Soil	2-12
Lead in Water	2-14
Lead in Air	2-16
Lead in Food	2-18
Other Sources	2-20
Lead Concerns Date Back to the Days of Ben Franklin	2-22



Inspecting for Lead Hazards



Background Information for Lead Inspectors



Objectives

The objectives of this chapter are to

- provide inspectors with an understanding of the history of lead poisoning;
- acquaint inspectors with the uses of lead;
- describe the sources of lead exposure;
- help inspectors to recognize the extent of the lead hazard.



Learning Tasks

After completing this chapter, inspectors should be able to

- explain the history and uses of lead;
- recognize the presence of lead-based paint and lead hazards in a dwelling.

As an inspector, this section is important because

- understanding lead and its uses will allow an inspector to inspect the dwelling unit for the presence of lead-based paint and lead-contaminated soil and dust, as required; and
- residents of dwellings being inspected may question an inspector involved in the lead-based paint inspection or clearance-testing process about what they are doing and why.

Background Information for Lead Inspectors



History of Lead Use

Elemental lead is a heavy, soft, easily worked, bluish metal. Lead deposits are often found in the form of galena, a lead-sulfide mineral associated with zinc sulfides and silver. In fact, lead was recovered in early times as a by-product of the smelting of silver.

Nearly all of the lead in the human environment results from human activities. Once lead is mined, processed, and introduced into the human environment (i.e., the lead that people encounter in their environment), it is a potential problem forever. No current technology will destroy it or make it permanently harmless. However, exposures to lead can be controlled.

Lead has been mined, smelted, and made into products for thousands of years. The oldest known lead object is an 8,500 year old statue that was excavated in Turkey. Lead objects also have been found in ancient Egyptian tombs that are approximately 8,000 years old. In ancient Syria, lead was fashioned into rods and pieces that were used as money.

World production of lead 4,000 years ago has been estimated at 160 tons per year; 2,700 years ago, production was 10,000 tons per year; and, during the Roman Empire, lead production increased to 80,000 tons per year.

Romans were responsible for developing practical uses for lead; for instance, around 2,300 years ago, the first Roman aqueduct was built to supply the city of Rome with water from a source about seven miles away. Incoming water was distributed through a system of lead pipes. During the Roman Empire, lead was used extensively in many other objects, such as lining vessels that stored water and wine; making utensils; and, in combined form, as glazing on pottery. Some researchers think that the decline of the Roman Empire can be attributed partly to lowered birth rates and increased mental problems caused by lead poisoning.

After the industrial age began in the 1800s, the use of lead increased, and with it, the potential for occupational exposures. Lead's versatility, as well as its favorable physical and chemical properties, accounted for its popularity. Much of lead's usefulness is because it is soft, the softest of all common metals, and easily worked. It can be rolled into sheets that can then be made into rods and pipes. It can be molded into containers and combined with other metals. Consequently, lead has been used in building construction, especially for roofing, cornices, electrical conduits, water pipes, and sewer pipes. Centuries of mining, smelting, and use of lead have released millions of tons of the metal into the environment.

Lead is a heavy metal that is mined from the earth.

The use of lead increased in the industrial age of the 1800s.

Lead is a soft metal.



Lead Poisoning

Although the ancient Greeks were the first to write about lead poisoning, unfortunately lead has not been recognized as a hazard for most of its long history. In fact, doctors over the years have used lead as a "treatment" for various diseases. A medical dictionary printed in 1745 suggests that lead dissolved in a mild acid such as vinegar could be used to cure sores or skin diseases. Others have claimed that lead therapy could cure consumption, diabetes, dysentery, and epilepsy.

The occupational hazards of lead were first reported in 1713 by Bernardo Ramazzini, who described lead intoxication in potters working with lead glazes. In the later part of the 1700s, Benjamin Franklin (who was a printer and handled lead type) described the toxic effects of lead on workers who used lead in their jobs. These workers included printers, plumbers, and painters. In a now famous letter to his friend Ben Vaughan, Franklin wrote of his concern that no one seemed to be doing anything to protect people from the known poisonous nature of lead (see page 2-22). In 1913, Dr. Alice Hamilton, an American occupational health doctor, wrote about painters and the hazards of their work. She documented their exposure to lead and their health problems.

Lead Pigments

Lead compounds (chemicals consisting of lead in combination with other elements, for example oxygen or chromium), such as white lead and lead chromate, have been widely used as pigments in paint. Table 2-1 contains a list of lead pigments and their corresponding color. Lead is also present in varnishes, stains, shellacs, and primers. Lead has been used in paint for three main reasons:

- as a pigment;
- to add durability and corrosion control;
- as a drying agent.



The use of lead in paint declined in the United States

during the 1950s as titanium dioxide and latex paints became popular. Additionally, the lead paint industry established a voluntary industry standard for residential lead-based paint of one percent (1.0%) in 1955. This limit was adopted as a federal limit by Congress as part of the Lead-based Paint Poisoning Prevention Act (LBPPPA) in 1971, and was revised downward to 0.06 percent (0.06%) in 1978. This level of lead in paint is still in effect for use on interior and exterior residential surfaces, toys, and furniture. Although the use of lead-based paint, in particular on interior surfaces, has declined over the years, most housing units built before 1980 contain some lead-based paint.

Lead compounds were put in paint as a pigment, for durability, and as a drying agent.



Background Information for Lead Inspectors

Table 2-1 Lead Pigments

Pigment	Color
Lead acetate	White
Dry white lead, basic carbonate	White
Dry white lead, basic sulfate	White
White lead in oil	White
Litharge (lead oxides)	Yellow, black, black red
Red lead	Orange
Blue lead	Blue
Orange mineral	Orange
Grinder's lead in oil	White
Pig lead	Gray
Lead chromate/oxide	Orange
Basic lead chromate	Red
Lead chromate	Yellow
Lead chromate (green)	Green
Basic lead silico-chromate	Red orange
Basic silicate white lead	White

(Source: Gooch, J., *Lead-Based Paint Handbook*, Plenum Press: New York, 1993)



Sources of Environmental Lead Contamination

Although lead occurs naturally in small quantities in the earth's crust, by far the greatest risk of exposure to lead that people face comes from man-made processes and products. The use of large quantities of lead over many years has resulted in extensive environmental contamination.

Currently, the principal industrial use of lead is in the manufacture of electrical storage batteries. Other uses include the production of ammunition, various chemicals, and sinkers for fishing. Although the use of lead in paint additives, gasoline additives, solder, and pipes has been reduced or eliminated, the old products and their remains can still be found in the environment.

Most adults are exposed to lead in the workplace.

Most children are exposed to lead in surface dust and soil contaminated with lead.



The major exposure to lead for most adults comes from the work place. Surface dust and soil contaminated with lead are the major sources of lead exposure for infants and young children. Young children frequently play on floors and in outside areas, and they may put lead-contaminated fingers, toys, and other objects in their mouths. Lead also can be found in airborne dust during refinishing or renovation activities or because of windblown surface dust, but air is a less important source of lead exposure for children. Children are also often exposed to lead that is brought into the house on their parents' work clothes.

A person may become poisoned through exposure to a single high-level source of lead or through the cumulative effect of repeated exposures to several low-level sources of lead. High-level exposures can occur on the job or from the environment, such as from deteriorating paint in the home. High-level or acute lead exposures can result in severe health problems, including convulsions, coma, and even death. Although deaths are now rare, a young boy in Wisconsin died in the early 1990s from lead-based paint poisoning.

Experts agree childhood lead poisoning can be attributed to

- lead-based paint in housing;
- lead in interior and exterior surface dust (through hand-to-mouth transmission);
- urban soil (contaminated from lead-based paint, gasoline, and industrial sources);
- drinking water (primarily from leaded solder; brass fittings and fixtures; and service lines).

These sources are considered major sources of lead exposure because they generally expose many people. Other sources can result in high exposures to lead in individual cases. Contributions from these other sources add to the problem and are, therefore, of potential concern.



Lead in Paint

Lead in Residential Paint and Housing

Lead-based paint was used inside homes on woodwork, walls, floors, windows, doors, and stairs because it resisted wear and tear. It was also used on the outside of homes, porches, windows, and doors because it can withstand extreme weather changes.

Lead-based paint kills mold and mildew. Because mold and mildew typically grow in high moisture areas, lead-based paint was often used in places where moisture is found (such as kitchen and bathroom walls and on windows and doors). White lead (lead carbonate) was used extensively in white and light-colored paints, but it has been replaced by titanium dioxide, which is cheaper, easier to use, and a brighter white.

The amount of lead-based paint in housing is significant—approximately 64 million private U.S. residences contain at least some lead-based paint.¹ An estimated 14 million of the pre-1980 private dwellings contain deteriorating lead-based paint; children under six live in approximately four million of these dwellings. Research studies have shown an association between the presence of lead-based paint and the presence of excessive levels of lead in dust and soil (Clark, 1991; Bellinger, 1991; Roberts, 1991; Chisolm, 1985; Farfel, 1990; Farfel, 1994; National Academy of Sciences, 1993).



Children living in homes with lead-based paint can become exposed to that lead by directly eating chips of lead-based paint or chewing on protruding surfaces painted with lead-based paint. However, the more common route of exposure is by ingesting lead-bearing dust that is formed by the paint when it deteriorates, chinks, or is disturbed through renovation or even abrasion from the opening and closing of windows and other friction and impact surfaces. Even in this less direct way, lead-based paint can be a source of severe lead poisoning.

Often, children ingest lead-based paint by normal hand-to-mouth activity. Infants and young children commonly put nonfood objects covered with lead-containing dust or paint into their mouths, while toddlers frequently handle toys and are exposed to accessible surfaces such as window sills. Young children absorb a significantly higher

LBP was used on interior and exterior surfaces because it was durable.

Approximately 64 million private U.S. homes contain some lead-based paint.

Lead dust is generated when paint deteriorates or is disturbed.

Children ingest lead dust by normal hand-to-mouth contact.

¹ Report on the National Survey of Lead-Based Paint in Housing, April 1995, USEPA.



percentage of ingested lead than adults. Lead absorption is increased by malnutrition and poor diet.

Child-occupied facilities such as day-care facilities present a potential source of lead exposure to children. The day-care facility can have the same problems as an individual house (i.e., deteriorating paint inside and chalking of paint outside the facility, and dust, soil, or water contaminated with lead).

Lead-Based Paint Hazards in Housing

- Approximately 64 million pre-1978 housing units contain some lead-based paint.
- An estimated 13.8 million housing units contain deteriorating lead-based paint.
- Roughly 6 million pre-1979 housing units are reported to be in poor physical condition.
- Approximately 400,000 pre-1979 housing units are economically distressed, in poor physical condition, and occupied by a child under age 6.

Sources: *Report on the National Survey of Lead-based Paint in Housing Base Report*, EPA-747-R95-003, USEPA, April 1995.

Putting the Pieces Together: Controlling Lead Hazards in the Nation's Housing, National Lead-based Paint Hazard Reduction and Financing Task Force Report, 1995.



Background Information for Lead Inspectors

Although more than 60 percent of houses built between 1940 and 1979 contain some lead-based paint, the greatest risk is in housing built before 1940.² Older dwellings tend to contain paint with higher concentrations of lead (up to 50 percent by dry weight) as well as more coats of paint.³ Therefore, older dwellings are generally a higher priority for lead-hazard controls.

Lead in Industrial Paints

A number of lead compounds are very brightly colored and thus can be used in pigments to provide different colors in paints. For example, lead chromate is the pigment typically used in yellow road-marking paint. Red lead is used as a corrosion-resistant pigment in paints used to protect steel exposed to severe corrosion conditions (bridges and marine use). Lead-based paint is still used on bridges and on the inside and outside of steel structures to prevent rust and corrosion. These are "industrial uses" of lead-based paint. There are no federal restrictions on the use of lead-based paint for industrial purposes.

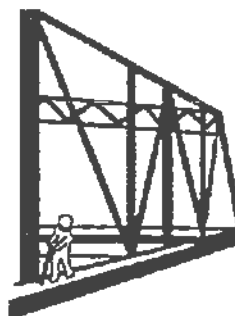

Industrial paints still contain high levels of lead.

Blasting or grinding lead-based paint off steel structures and even performing routine repairs creates huge amounts of lead dust. Doing this type of work can be harmful to workers and the surrounding community as the lead dust gets into the air and nearby soil, plants, and water.

² *Report on the National Survey of Lead-based Paint in Housing, Base Report, EPA-747-R95-003, USEPA, April 1995.*

³ *Putting the Pieces Together: Controlling Lead Hazards in the Nation's Housing, National LBP Hazard Reduction and Financing Task Force Report, 1995.*



Lead In Surface Dust and Soil

Research has confirmed the association between dust lead and children's blood lead levels.

Several studies published during the past two decades by the United States Environmental Protection Agency (EPA), the Agency for Toxic Substances and Disease Registry (ATSDR), and investigators at the University of Cincinnati and University of Rochester have confirmed the association between dust lead and childhood blood lead. The size of the lead particles and the chemical form of the lead affect how much of the lead in dust and soil may eventually accumulate in the body. The relationship between soil/dust lead and blood lead levels in children is also affected by access to soil, behavior patterns, presence of ground cover, and a variety of other factors.

Surface dust includes house dust and street dust. Soil may be divided into the very top layer of soil with which people are in contact and soil below the very top layer. Lead in surface dust and soil of all types can come from

- weathering and chipping of lead-based paint;
- scraping and sanding of lead-based paint in preparation for refinishing;
- renovations that break surfaces painted with lead-based paint;
- abrasion and/or impact on doors and windows;
- atmospheric fallout from the combustion of leaded gasoline that was deposited prior to the phase-down in use;
- factory emissions;
- dust and dirt that is carried into the home on shoes and clothing, especially from factories or construction sites or by pets.

EPA has established lead dust levels for interior surfaces.

The chance of a house having excessive dust lead is about twice as great if the house has high levels of interior lead-based paint than if it does not. However, most of the interior lead dust is only on the window sills or in the window troughs. About one million housing units (out of 20 million) have excessive lead dust exclusively on the floors. (EPA's interim guidance on lead-contaminated dust established the following levels for interior surfaces: 100 $\mu\text{g}/\text{ft}^2$ on floors, 500 $\mu\text{g}/\text{ft}^2$ on interior sills (stools), and 800 $\mu\text{g}/\text{ft}^2$ on window troughs.)

Dust and soil contaminated with lead are direct sources of exposure to children.

Soil outside the building is another direct source of childhood lead exposure, and a potential source of lead in house dust since soil can be tracked into the dwelling or blown in. If the house has exterior lead-based paint, there is a higher likelihood that the soil lead levels will be greater than EPA's level of concern (currently 400 parts per million). Lead contamination is most likely to be found around the outside of the house at the roof drip line. Dwellings close to major roadways may also have lead in soil because of deposits from leaded gasoline.



Background Information for Lead Inspectors

EPA has published interim guidance addressing lead levels in interior dust and exterior soil. These levels and the recommended actions they trigger are discussed in depth in Chapter 4 (Regulatory Background) and in Chapters 8 and 9 (Soil Sampling for Lead Contamination and Dust Sampling for Lead Contamination, respectively).





Lead In Water

Lead-contaminated drinking water also contributes to the overall level of exposure—from as little as 5 percent to more than 50 percent of a child's total lead exposure. Infants who are fed formula may receive as much as 85 percent of their lead exposure from drinking water. The percentage of exposure to lead attributable to drinking water varies with the levels of lead in the water and with the amount of other lead exposures.

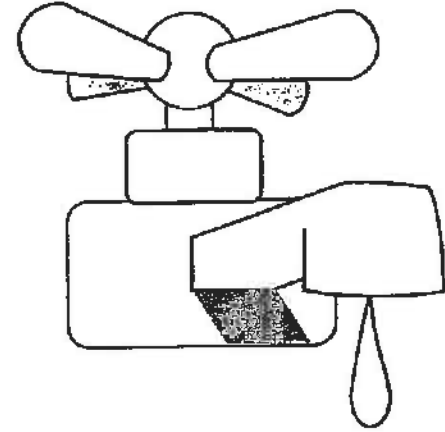

The main cause of lead contamination in drinking water is corrosion of lead-containing plumbing.

The main cause of lead contamination in drinking water is corrosion of lead-containing materials in household plumbing. In particular, poorly soldered joints where the solder contains lead and a lot of brass fittings may produce high lead levels in the water. Potential sources of lead in drinking water systems may include

- lead plumbing goosenecks or pigtails;
- lead service lines and interior household plumbing, especially where lead solder was used;
- lead-containing alloys, such as faucets or valves made of brass or bronze;
- private water wells and/or plumbing equipment;
- water service mains (rarely).

The amount of lead in drinking water attributable to corrosion depends on a number of factors, including

- the amount and age of lead-containing materials susceptible to corrosion;
- the amount of time the water is in contact with these materials;
- the corrosiveness of the water.

All naturally occurring water contains dissolved gases (oxygen and carbon dioxide) and dissolved solids (silicates, carbonates, sulfates, chlorides, and others) which can attack lead and cause it to corrode. Water's corrosiveness is determined by the water's acidity, temperature, and total dissolved solids. Hot, acidic, "soft" (low in dissolved solids) water is the most corrosive towards lead; cold, alkaline, "hard" water is least corrosive. New solder and brass fittings will release more lead into the water than older ones. However, as time passes, mineral deposits form a coating on the surface of materials in contact with the water that insulates the water from the lead and decreases the rate of corrosion.

Hot, acidic, and soft water is the most corrosive towards lead.



Background Information for Lead Inspectors

Long contact time between the water and lead-containing materials results in more dissolved lead in the water. Thus, water that remains in the plumbing overnight typically has higher lead levels than flushed water.

In 1986 Congress banned the use of lead-containing materials above specific percentages in public water supply systems and in any plumbing providing drinking water connected to public water systems. Therefore, the level of lead in drinking water should be decreasing.

In order to avoid duplication of effort, Title X does not define lead contamination in water as a lead-based paint hazard. Also, in many cases, it is beyond the control of the owner to effect any corrective measures. Additionally, under the EPA training and certification rules, (Section 402 of TSCA), water sampling is included as a part of a risk assessment, *not* an inspection. Therefore, lead-based paint inspectors cannot collect water samples or recommend corrective measures.



The phase-down of leaded gasoline use has significantly reduced the level of lead in the air in the U.S.

Lead In Air

Because of the EPA-mandated phase-down in the use of leaded gasoline, lead contamination in air has significantly reduced over the past 20 years. EPA reports that total atmospheric lead emissions dropped 94 percent between 1978 and 1987 because of its phase-down of leaded gasoline, the introduction of unleaded gasoline in new cars, and a decrease in the number of vehicles that burn leaded gasoline. This reduction of lead in air correlates very well with declines in childhood blood lead levels between 1976 and 1991, as documented by the second and third National Health and Nutrition Examination Surveys (NHANES II and III) (see Figure 2-1).

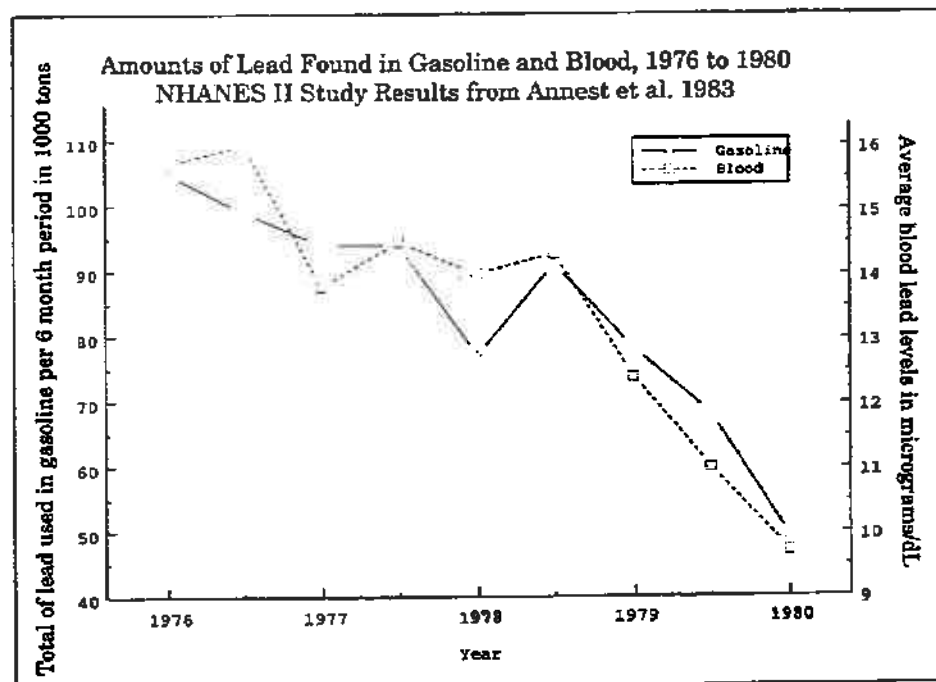

Figure 2-1. Comparison of reduction of lead in gasoline and blood lead levels in the U.S. 1976-1980.

Industrial sources and demolition also contribute to lead levels in the air.

However, leaded gasoline is not the only source of lead contamination in air. Air can also be contaminated by emissions from stationary sources, such as smelters and battery factories, and from the combustion of oil, coal, waste oil, and municipal wastes. Windblown dust is another source of air contamination. Studies in Ohio (University of Cincinnati and Case-Western Reserve University) have demonstrated that dust from the demolition of old buildings is a major contributor to neighborhood dust and soil lead levels. Lead emissions from industrial and other stationary sources have declined because of compliance with state plans and regulations aimed at achieving national air quality standards.

Background Information for Lead Inspectors



Lead contamination in air remains a significant problem at many worksites, especially where renovation, lead abatement, and recoating of bridges or other steel structures are conducted. The National Institute of Occupational Safety and Health (NIOSH) reports that workers are frequently poisoned by lead while working on bridges (a high percentage of bridges are painted with lead-based paint). Operations such as abrasive blasting, sanding, burning, or welding on steel structures coated with lead-containing paints may produce very high concentrations of lead dust and fumes. If these activities are not properly contained, the dusts and fumes generated can drift and contaminate waterways and adjacent neighborhoods.

Abrasive blasting, sanding, and burning on steel structures may produce very high concentrations of lead dust and fumes.



Imported canned foods may still contain lead solder.

Lead In Food

Food can be contaminated with lead

- from containers with lead solder, lead glaze, or other materials with lead, especially if contents are acidic in nature (for example acidic fruit juices, beer, wine);
- by airborne lead from industrial or automobile emissions deposited onto crops or water;
- by uptake into food crops from lead in soil or pesticide applications;
- during transportation or processing.

In food processing, the primary source of lead has been solder in the seams of cans. A phase-out of lead solder in cans began in the late 1970s, resulting in a significant reduction in lead in canned food. The Food and Drug Administration (FDA) has developed a comprehensive plan to address lead exposure through food and food-contact surfaces in the United States. However, imported canned foods may still contain lead solder.

Food Containers

Lead oxide is sometimes used to manufacture glazes for protecting ceramics and as a component in enamels for coating cast iron, glass, and aluminum. The lead in the glazing can leach into food or beverages that come in contact with the glaze. This leaching is most dependent upon the temperature at which the ceramics are "fired" in a kiln. Ceramics fired in a low temperature kiln are much more likely to leach lead when in contact with food or beverages than ceramics fired in a high temperature kiln. This leaching is also more likely with foods or beverages that are hot (e.g., hot cocoa or coffee) or acidic (e.g., tomato-based products, orange juice, coffee).

Beginning around the 15th century, the English began manufacturing some glass and crystal with large amounts of lead oxide to give the glass a more brilliant appearance; other countries soon followed suit. Thus, pottery, ceramic cookware, plates (especially imported pieces), and crystal may contain high levels of lead. Food or beverages stored in these items can become highly contaminated with lead.

The lead in glazing on ceramics fired at a low temperature can leach into food or beverages.





Background Information for Lead Inspectors

Cosmetics and Home Remedies

Finally, some home remedies ("folk medicines") used by some minority communities for intestinal disorders or skin rashes contain high levels of lead. Table 2-2 lists some of these home remedies.

Table 2-2 Dangerous Home Remedies

Name	Appearance	Use	Misc.
Azarcon (Also known as <i>Rueda, Coral,</i> <i>Maria Luisa,</i> <i>Alarcon, Ligo</i>)	Bright orange powder	Given for "empacho" (intestinal illness)	Almost 100% lead. Any amount is poisonous to children and adults.
Greta	Yellow powder	Given for "empacho" (intestinal illness)	Almost 100% lead. Any amount is poisonous to children and adults.
Pay-loo-ah	Red powder	Given for rash or fever	Hmong community
Ghasard	Brown powder	Given as an aid to digestion	Asian Indian community
Bala Goli	Round, flat, black bean dissolved in "gripe water"	Used for stomachache	Asian Indian community
Kandu	Red powder	Used to treat stomachache	Asian Indian community
Kohl (Alkohl)	Powder	Used both as a cosmetic eye make- up and applied to skin infections and the navel of a newborn child	Arab American community

Some home remedies contain high levels of lead.

Source: *Lead in Home Remedies*, California Department of Health Services, April 1994.



Proper decontamination can prevent adults from bringing lead home on their work clothes, shoes, and hair.

Other Sources

Although discussions concerning lead poisoning are often focused on children, adults also are affected by lead. Probably the greatest use of lead is in the manufacture of electrical batteries.⁴ Solders that require low melting points but rapid solidification are used in electronic parts and the manufacture of printed circuits; these solders typically contain large amounts of lead.

Adults who work in certain industries, such as smelting, auto body repair shops, painting shops, scrap metal works, electrical work, demolition, and construction (including lead abatement, renovation, and remodeling) can be at risk to lead poisoning. Moreover, if care and precautions are not taken, they may carry lead-contaminated dust into their homes on work clothes, shoes, and hair. Proper personal hygiene and work-practice precautions must be followed by workers in all of these industries to prevent bringing lead dust home on their clothing. Also, hobbyists working with stained glass or pottery and sportsmen who make their own bullets or fishing weights should exercise caution to minimize lead exposure.



⁴ Bureau of Mines, 1992.



Background Information for Lead Inspectors

Vinyl miniblinds are another potential source of lead in a residence. In June 1996, the Consumer Product Safety Commission (CPSC) issued an alert warning of the possible dangers presented by imported vinyl miniblinds. After testing and analyzing vinyl miniblinds, the CPSC determined that some brands present a lead poisoning hazard for young children. Twenty-five million non-glossy, vinyl miniblinds that had lead added to stabilize the plastic were imported each year from China, Taiwan, Mexico, and Indonesia. CPSC found that over time the plastic deteriorates from exposure to sunlight and heat to form lead dust on the surface of the blind. The amount of lead dust that formed varied depending on the manufacturer. Based on these findings and at the request of CPSC, the vinyl miniblind industry began using a different formulation for the miniblinds. These new lead-free miniblinds became available to consumers in July/August 1996. CPSC and CDC recommend that parents with young children remove old vinyl miniblinds from their houses and replace the miniblinds with alternative window coverings or with new miniblinds made without added lead.

The CDC, CPSC, and the public health community have identified the following products as sources of lead exposure, especially for children:

- crayons (imported from China),
- painted metal playground equipment,
- pool cue chalk,
- calcium supplements (made from bone or oyster shell),
- some hair dyes (lead acetate).*

(*The lead in some hair dyes is a potential risk to children if they assist in applying the dye to a parents' hair or if the parent doesn't wash their hands after application and residue contaminates fixtures and counter tops.)

**Many products
can contain lead.**



Lead Concerns Date Back to the Days of Ben Franklin

In 1786, Benjamin Franklin wrote a lengthy letter to his friend, Benjamin Vaughan, describing the effects of lead exposure he had personally observed. Included is the following excerpt which describes exposures from paint and water sources. Benjamin Vaughan was a youthful admirer and close friend of Franklin, who was 80 years old when he wrote to Vaughan. The letter press copy of Franklin's communication is in the Library of Congress.

The letter is reproduced here with the original capitalization and spelling.

Phil July 31. 1786

Dear Friend,

I recollect that when I had the great Pleasure of seeing you at Southampton, now a 12 month since, we had some Conversation on the bad Effects of Lead takin inwardly; and that at your Request I promis'd to send you in writing a particular Account of several Facts I then mention'd to you, of which you thought some good Use might be made. I now sit down to fulfil that Promise.

The first thing I remember of this kind, was a general Discourse in Boston when I was a Boy, of a Complaint from North Carolina against New England Rum, that it poison'd their People, given them the Dry Bellyach, with a Loss of the Use of their Limbs. The Distilleries being examin'd on the Occasion, it was found that several of them used leaden Still-heads and Worms, and the Physicians were of Opinion that the Mischief was occasion'd by that Use of Lead. The Legislature of the Massachusetts thereupon pass'd an Act prohibiting under severe Penalties the Use of such Still-heads and Worms thereafter. Inclos'd I send you a Copy of the Act, taken from my printed Law books.

In 1724, being in London, I went to work in the Printing-House of M Palmer, Bartholomew Close as a Compositor. I there found a Practice I had never seen before, of drying a Case of Types, (which are wet in Distribution) by placing it sloping before the Fire. I found this had the additional Advantage, when the Types were not only dry'd but heated, of being comfortable to the Hands working over them in cold weather. I therefore sometimes heated my Case when the Types did not want drying. But an old workman observing it, advis'd me not to do so, telling me I might lose the Use of my Hands by it, as two of our Companions had nearly done, one of whom that us'd to earn his Guinea a Week could not then make more than ten Shillings and the other, who had the Dangles, but Seven and sixpense. This, with a kind of obscure Pain that I had sometimes felt as it were in the Bones of my hand when working over the Types made very hot, induc'd me to omit the Practice. But talking afterwards with M James, a Letter-



Background Information for Lead Inspectors

founder in the same Close, and asking him if his people, who work'd over the little Furnaces of melted Metal, were not subject to that Disorder; he made light of any Danger from the Effluvia, but ascrib'd it to Particles of the Metal swallow'd with their Food by slovenly Workmen, who went to their Meals after handling the Metal, without well-washing their Fingers, so that some of the metalline Particles were taken off by their Bread and eaten with it. This appear'd to have some Reason in it. But the Pain I had experienc'd made me still afraid of those Effluvia.

Being in Derbshire at some of the Furnaces for Smelting Lead Ore, I was told that the Smoke of those Furnaces was pernicious to the neighboring Grass and other Vegetables. But I do not recollect to have heard any thing of the Effects of such Vegetables eaten by Animals. It may be well to make the Enquiry.

In America I have often observ'd that on the Roofs of our shingled Houses where Moss is apt to grow in northern Exposures, if there be any thing on the Roof painted with white Lead, such as Balusters, or Frames of dormant Windows, etc. there is constantly a streak on the Shingles from such paint down to the Eaves, on which no Moss will grow, but the Wood remains constantly clean and free from it. We seldom drink Rain Water that falls on our Houses; and if we did, perhaps the small Quantity of Lead descending from such Paint, might not be sufficient to produce any sensible ill Effect on our Bodies. But I have been told of a Case in Europe, I forgot the Place, where a whole Family was afflicted with what we call the Dry-Bellyach, or Colica Pictonum, by drinking Rain Water. It was at a Country Seat, which being situated so high to have the Advantage of a Well, was supply'd with Water from a Tank which receiv'd the Water from the leaded Roofs. This had been drank several Years without Mischief; but some young Trees planted near the House, growing up above the Roof, and shedding their Leaves upon it, it was suppos'd that an Acid in those Leaves had corroded the Lead they cover'd, and furnish'd the Water of that Year with its baneful Particles and Qualities.

When I was in Paris with Sir John Pringle in 1767, he visited La Charite, a Hospital particularly famous for the Cure of that Malady, and brought hence a Pamphlet, containing a List of the Names of Persons, specifying their Professions or Trades, who had been cured there. I had the Curiosity to examine that List, and found that all the Patients were of Trades that some way or other use or work in Lead; such as Plumbers, Glasiers, Painters, etc. excepting only two kinds, Stonecutters and Soldiers. There I could not reconcile to my Notion that Lead was the Cause of that Disorder. But on my mentioning this Difficulty to a Physician of that Hospital, he inform'd me that the Stonecutters are continually using melted lead to fix the End of Iron



Inspecting for Lead Hazards

Balustrades in Stone; and that the Soldiers had been employ'd by Painters-Labourers in Grinding of Colours.

This, my dear Friend, is all I can at present recollect on the Subject. You will see by it, that the Opinion of this mischievous Effect from Lead, is at least above Sixty Years old; and you will observe with Concern how long useful Truth may be known, and exists before it is generally receiv'd and practis'd on.

I am, ever,
Yours most affectionately
B. Franklin

Background Information for Lead Inspectors





CHAPTER 3

HEALTH EFFECTS OF LEAD EXPOSURE

Objectives	3-3
Learning Tasks	3-4
Introduction	3-5
How Lead Enters the Body	3-7
What Happens to Lead in the Body	3-9
Symptoms of Lead Poisoning	3-10
Acute Lead Poisoning	3-10
Chronic Lead Poisoning	3-10
Biological Evaluation	3-13
The Level of Concern	3-14
Treatment	3-17
Summary	3-18



Inspecting for Lead-based Paint





Health Effects of Lead Exposure

Objectives

The objectives of this chapter are to

- provide a basic understanding of the symptoms from acute and chronic lead poisoning;
- explain how lead enters and affects the body;
- explain why lead is especially dangerous to children;
- provide inspectors with an understanding of the health hazards associated with exposure to lead and the “level of concern” for lead in blood.



Learning Tasks

After completing this chapter, inspectors should be able to

- describe the health effects of lead;
- recognize the symptoms of lead poisoning;
- explain the routes of entry of lead into the human body.

As an inspector, this section is important because

- the extent of the problem should be understood in order to fulfill effectively your role in the testing process.



Health Effects of Lead Exposure

Introduction

The severity of the health effects of lead contamination is only now being fully realized. Lead in the body can cause serious damage to almost all systems within the body. The three systems where the effects are most dangerous are

- the central and peripheral nervous systems
- the cardiovascular system, including the blood forming system
- the kidneys

Exposure to high concentrations of lead can cause

- retardation
- convulsions
- coma
- death (sometimes)

Children are especially vulnerable to and susceptible to lead poisoning. High levels of lead in the blood of young children can produce permanent nervous-system damage. Even at low levels, lead exposure continuing during childhood is known to slow a child's normal development, causing learning and behavioral problems. Often, low blood lead levels do not have obvious symptoms. The Agency for Toxic Substances and Disease Registry (ATSDR), as well as numerous other investigators, reports long-lasting affects on intelligence, motor control, hearing, and emotional development of children who have levels of lead in the body that are not associated with obvious symptoms.

From 1976 to 1991 the National Health and Nutrition Examination Surveys (NHANES), an ongoing series of national examinations of the health and nutritional status of the general public, reported a significant decrease in the blood lead levels of children. Lead gasoline, soldered cans, and lead-based paint are considered major sources of lead during the period of the NHANES surveys. According to data from NHANES II and III, mean blood lead levels in children decreased 77 percent, from 13.7 $\mu\text{g}/\text{dL}$ to 3.2 $\mu\text{g}/\text{dL}$. Lead source reduction is attributed to removing 99.8 percent of lead in gasoline (current regulations allow only 0.05 grams/gallon), banning lead-soldered food containers, and reducing lead in paint to 0.06 percent by weight.¹

Data collected during the second phase of NHANES III indicated that blood lead levels in the U.S. population continued to decrease (down to 2.3 $\mu\text{g}/\text{dL}$). Despite these declines, about *one million children* aged one to five years have blood lead levels greater or equal to 10 $\mu\text{g}/\text{dL}$. The risk for

Lead in the body can cause serious damage.

Children under six are especially vulnerable to lead poisoning.

Many of the effects of lead poisoning cannot be reversed.

Almost one million children aged one to six have too much lead in their blood.

¹ *Journal of the American Medical Association*, Vol. 272, No. 4:284-291, 27 July 1994.



lead exposures remains disproportionately high for some groups, including children who are

- poor;
- Mexican American;
- non-Hispanic black;
- living in a large metropolitan area;
- living in older housing.²

Several studies evaluating the effects of lead on adults and children were published in 1996. One study evaluated the association between body lead burden and social adjustment in a population of first-grade boys. The researchers concluded that lead exposure in childhood is associated with increased risk for antisocial and delinquent behavior.³

Two studies evaluating the effects of lead on adults reported a link between lead and hypertension (high blood pressure) and lead and impaired kidney function. Researchers at Harvard Medical School, Harvard School of Public Health, and the Veterans Administration studied the relationship between long-term lead accumulation and the development of hypertension. The study subjects were participants in a study of aging previously established by the Veterans Administration (now Department of Veterans Affairs) in 1961. Both blood lead levels and bone lead measurements were evaluated. The results indicate that long-term lead accumulation may be a significant risk factor for the development of hypertension in men.⁴

Studies to determine whether low-level lead exposure may be associated with impaired kidney function were conducted by researchers at Harvard Medical School, Harvard School of Public Health, and the Department of Veterans Affairs Outpatient Clinic. Results of this research suggest that even low-level lead exposure may impair kidney function in middle-aged and older men.⁵

² *Morbidity and Mortality Weekly Report*, Vol. 46, No. 7:141-146, 21 Feb 1997.

³ Needleman, et al., *Journal of the American Medical Association*, Vol. 275, No. 5, 7 Feb 1996.

⁴ Hu, et al., *Journal of the American Medical Association*, Vol. 275, No. 15, 17 April 1996.

⁵ Kim, et al., *Journal of the American Medical Association*, Vol. 275, No. 15, 17 April 1996.

Children who are poor and live in poorly maintained housing are most at risk of lead poisoning.

Lead exposure can permanently damage the kidneys.



Health Effects of Lead Exposure

How Lead Enters the Body

When exposed to an environment that contains lead, a person can take lead into body tissues through eating (ingesting) or breathing (inhaling) fine particles of lead compounds. Inhalation and ingestion are the routes of exposure for both children and adults.

Children are more likely to ingest lead-contaminated dust through normal hand-to-mouth activity as they explore their environment. Activities such as thumb-sucking, putting nonfood items into their mouths, crawling on surfaces contaminated with lead dust, or mouthing lead-painted surfaces such as window sills are routes of exposure for young children



Many jobs or occupations can expose adults to lead. Workers can ingest and/or inhale lead particles if they do not use appropriate personal protective measures and good personal decontamination practices. They may also contaminate their cars and houses with lead dust on their clothes, shoes, hair, or skin. There have been many documented cases of entire families being lead poisoned from "take-home lead."

Inspectors run a risk of lead exposure both during paint inspections and when conducting clearance inspections. Inspectors should use good personal hygiene practices during and after an inspection. Inspectors should never eat, drink, or smoke on the worksite and should thoroughly clean their faces and hands before doing so after leaving the worksite. Additionally, inspectors should use appropriate personal protective equipment (gloves, respirator, protective clothing, etc.) if they are likely to come in contact with lead-contaminated dust. OSHA requires the use of some or all of these items depending on what activities are involved and/or what the airborne levels of lead are. (For more information on the OSHA lead regulations, see Chapter 4.)

Some jobs that have a high risk of lead exposure include:

Construction trades

- Lead abatement workers
- Carpenters
- Remodelers/renovators

Lead enters the body through eating or breathing fine particles of lead.

Children are most likely to ingest lead-contaminated dust through normal hand-to-mouth activity.

Most adults are exposed to lead at work.

Inspectors should never eat, drink, or smoke on the worksite.



Many occupations
expose adults to
lead.

Inspecting for Lead-based Paint

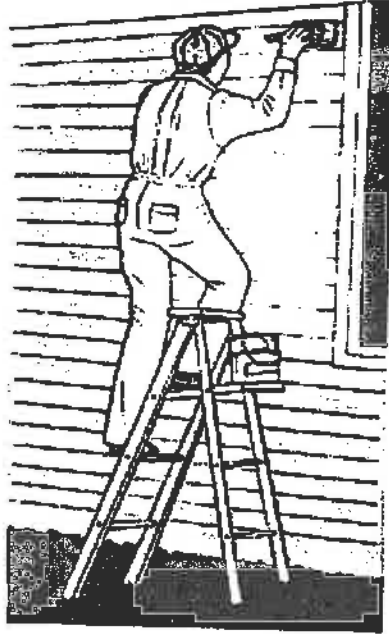

- Demolition workers
- Ironworkers
- Steel welders and cutters
- Sheet metal workers
- Painters
- Plumbers and pipe fitters
- Cable splicers

Industry

- Lead miners
- Lead smelter workers
- Lead refinery workers
- Lead crystal makers
- Ceramic glaze manufacturers
- Plastic manufacturers
- Wire and cable manufacturers
- Electronics makers



Others

- Firing range employees
- Police officers
- Artists
- Radiator repair workers
- Car mechanics
- Auto body repair
- Printers
- Scrap yard workers and recyclers



Health Effects of Lead Exposure

What Happens to Lead in the Body

Once in the body, lead is distributed by the bloodstream to red blood cells, soft tissue, and bone. Lead is eliminated very slowly from the body by the kidneys and gastrointestinal tract; very tiny amounts of lead are lost through perspiration.

Lead serves no useful purpose in the body. It is a poison that binds with the enzymes and other chemicals that aid biological reactions throughout the body—particularly in the blood-forming system; the brain and nerves; and the kidneys—interfering with the formation and breakdown of many body chemicals. Significant lead exposure may result in lead-induced anemia. Once lead enters the body, it may adversely affect many of the organ systems. Lead is stored in bone for decades, causing long-term internal exposure. Exposure prevention is essential because damage from lead poisoning may be permanent and, in some cases, fatal.

Lead serves no useful purpose in the body.

Where Lead is Stored in the Body

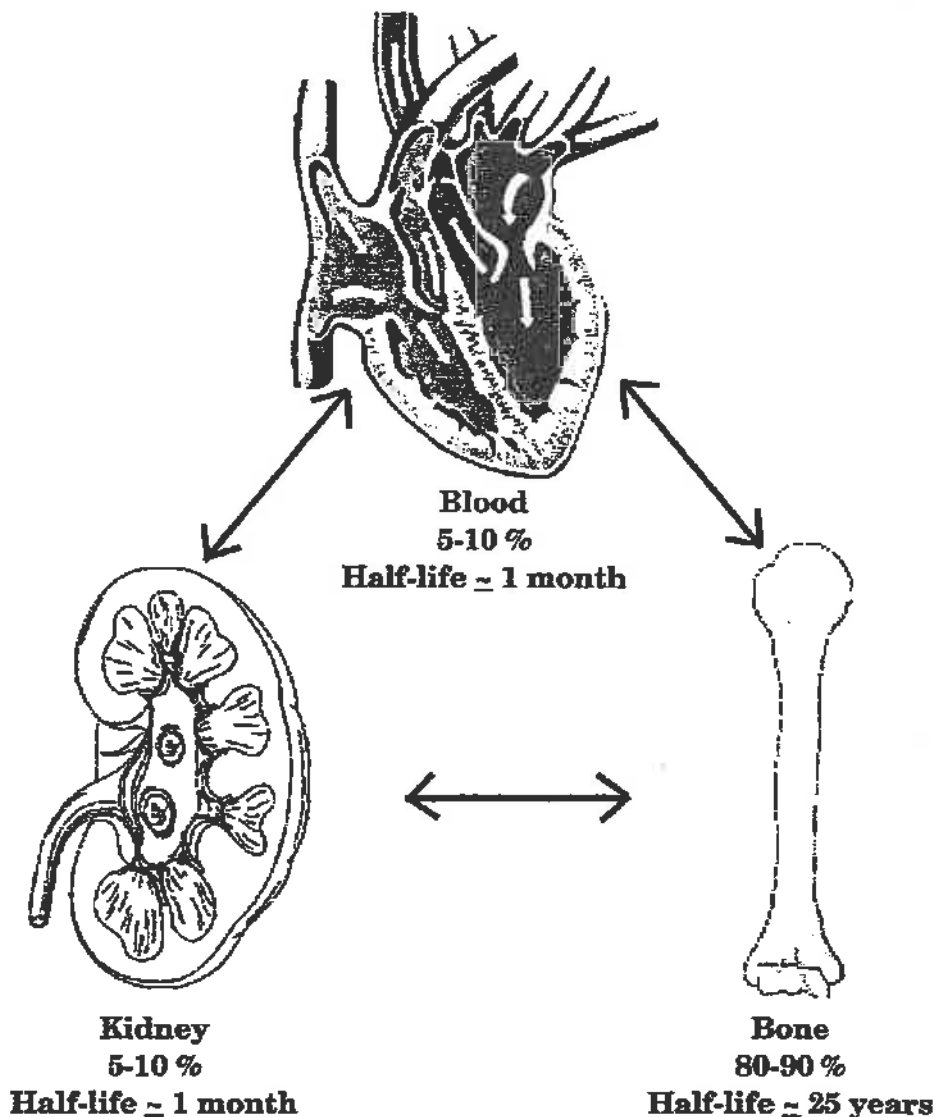

Lead is stored in the bone for decades.



Symptoms of Lead Poisoning

Since lead can affect almost all systems within the body, the symptoms of lead exposure are many. Some of these symptoms can occur with acute and/or chronic exposure to lead.

Acute Lead Poisoning

Acute exposure to lead generally means exposure for a short time, but at high levels.

The most common symptom in acute lead poisoning is colicky abdominal pain, evolving over days to weeks. Constipation or diarrhea may also occur. The abdominal pain may be severe enough to suggest an abdominal emergency such as a gall bladder attack or appendicitis.

The other major problems of acute lead poisoning are damage to the brain and central nervous system. This may lead to additional, nonspecific complaints including irritability, fatigue, weakness, and muscle pain. In more severe cases, warning symptoms of acute, serious brain swelling include vomiting, irritability, restlessness, tremors, and progressive drowsiness. These symptoms may herald the onset of seizures, coma, and possibly death. Rapid development of severe lead poisoning to this degree is uncommon, except in situations where there is massive, uncontrolled exposure to lead.

Some cases of acute lead poisoning may be associated with the interruption of the formation of red blood cells. This disruption causes anemia, which is one symptom of lead poisoning.

Chronic Lead Poisoning

Chronic lead exposure generally means exposure to low to moderate levels of lead over a long period of time.

Chronic lead poisoning may result after lead has accumulated over time in the body, mostly in the bone. Long after exposure has ceased, some event such as illness or pregnancy may release this stored lead from the bone and produce adverse health effects such as

- impaired blood formation;
- alteration in the central and peripheral nervous systems;
- high blood pressure;
- effects on the male and female reproductive systems (including no sex drive and deformed sperm);

The most common symptom of acute lead poisoning is colicky abdominal pain.

Lead can permanently damage the central nervous system.



Health Effects of Lead Exposure

- damage to the developing fetus (lead freely crosses the placenta).

Effects such as coughing, nausea, skin rashes, and liver and kidney disorders may result from both acute and chronic lead exposure.

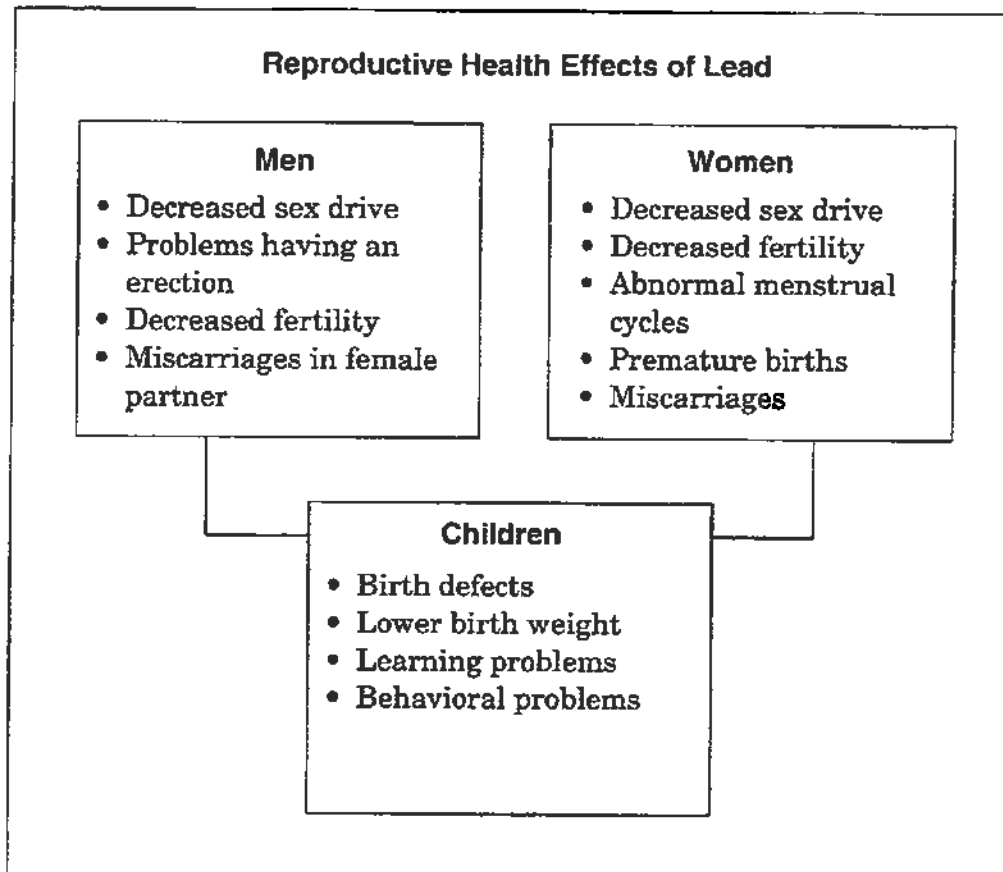

Lead affects the reproductive system of both men and women.



**You may not
know that lead is
harming you.**

Inspecting for Lead-based Paint

ADULT REACTIONS TO LEAD

Blood Lead Level	Possible Health Effects
15 $\mu\text{g/dL}$	Increase in blood pressure; harmful effects on fetus; joint and muscle aches
25 $\mu\text{g/dL}$	Reproductive problems
40 $\mu\text{g/dL}$	Kidney damage; damage to blood formation
60 $\mu\text{g/dL}$	Anemia; nerve damage; constipation; stomach pains; irritability and fatigue; memory and concentration problems; clumsiness; drowsiness and sleep problems
80 $\mu\text{g/dL}$ and above	Blue line on gums; uncontrollable shaking of hands; wrist and foot drop; hallucinations; brain damage; coma; death

ATSDR 1989; California Health Department 1993



Health Effects of Lead Exposure

Biological Evaluation

Exposure to lead is measured either by the concentration of lead in the material (air, water, food, dust, soil, or paint) to which people are exposed in the environment or by the concentration of lead in whole blood, usually expressed in micrograms of lead per deciliter of blood ($\mu\text{g/dL}$). Although there are some other clinical procedures to test for lead in the body, the blood lead level is the best initial measurement for evaluating lead exposure. It indicates the amount of lead circulating in the bloodstream, often a measure of recent exposure to lead. However, as noted above, lead absorbed in the bone in the past can be mobilized during pregnancy, wasting illness (such as cancer or AIDS), injury, or osteoporosis. Therefore, blood lead level is not always an indication of recent exposure.

A blood lead level is the best initial measurement for evaluating lead exposure in the body.



The Level of Concern

Over the past 30 years the Centers for Disease Control and Prevention (CDC) has responded to emerging knowledge about the effects of low-level lead exposure in children by progressively lowering the blood-lead level said to warrant medical intervention. In 1970 the level was 60 $\mu\text{g/dL}$. Shortly after the Lead-based Paint Poisoning Prevention Act was enacted in 1971, the level was lowered to 40 $\mu\text{g/dL}$. In 1975 the level was reduced to 30 $\mu\text{g/dL}$. In 1985 it was reduced still further to 25 $\mu\text{g/dL}$.

In October 1991 the intervention level was revised downwards to 10 $\mu\text{g/dL}$ (see Figure 3-1), and the single, all-purpose definition of childhood lead poisoning was replaced by a multitier approach to follow-up (see Table 3-1). The multitier approach emphasizes implementing primary prevention activities—eliminating lead hazards before children are poisoned—as blood-lead levels of concern are lowered. The CDC now states that the goal of all lead-poisoning prevention activities should be to reduce children's blood lead levels below 10 $\mu\text{g/dL}$. The CDC recommends that community prevention activities be undertaken if a significant number of children in the community have blood lead levels greater than or equal to 10 $\mu\text{g/dL}$. Medical evaluation, environmental investigation, and lead hazard controls should be implemented for all children whose blood lead levels are greater than or equal to 20 $\mu\text{g/dL}$. All children with blood lead levels greater than or equal to 15 $\mu\text{g/dL}$ should receive individual case management, including nutritional and educational interventions and more frequent screening. Furthermore, depending on the availability of resources, environmental investigation (including a dwelling inspection) and remediation should be done for

Figure 3-1. CDC blood lead levels of concern

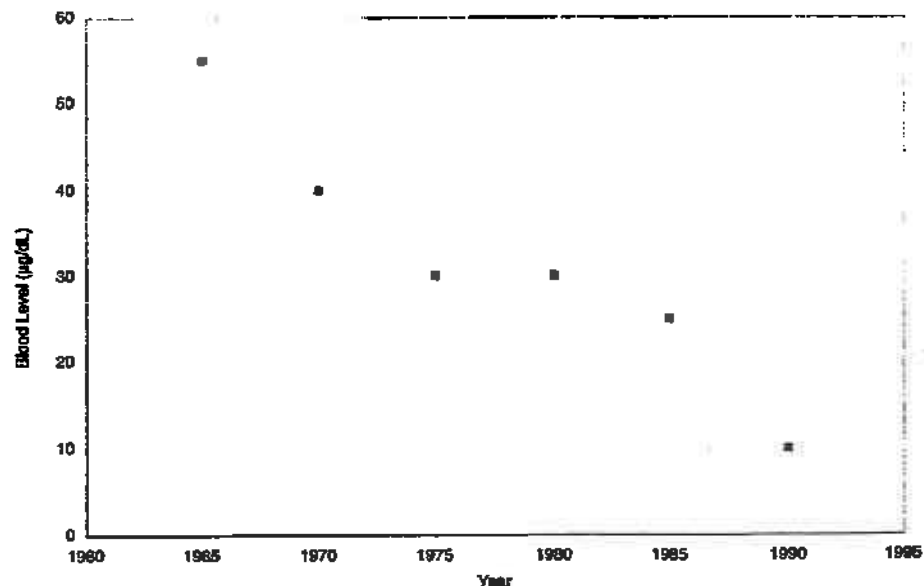

The level of concern for lead in children's blood is 10 $\mu\text{g/dL}$



Health Effects of Lead Exposure

children with blood lead levels of 15 to 19 $\mu\text{g}/\text{dL}$, if such levels persist. However, the highest priority should continue to be children with the highest blood lead levels.

Although intervention levels have been revised downwards, under no circumstances should 10 $\mu\text{g}/\text{dL}$ be regarded as a harmless level of blood lead. The present level of concern, 10 $\mu\text{g}/\text{dL}$, is far above the "natural background" blood lead level. In preindustrial humans, the blood lead level was on the order of 0.1 $\mu\text{g}/\text{dL}$, a factor of 100 lower than the present intervention level. Lead has no beneficial effects on humans. Moreover, the fatal dose to a young child is 100 to 150 $\mu\text{g}/\text{dL}$, only about 10 times the level of concern. Thus, the "safety factor" for lead is only about 10. The EPA and other agencies routinely require much higher safety factors for other environmental contaminants.

The Occupational Safety and Health Administration (OSHA) regulates adult's exposure to lead in the workplace. OSHA has established an allowable blood lead level of 40 $\mu\text{g}/\text{dL}$, while a blood lead level of 50 $\mu\text{g}/\text{dL}$ requires that the worker be removed from the lead exposed workplace. Healthy People 2000, a goal-oriented initiative of NIOSH and CDC, has established 25 $\mu\text{g}/\text{dL}$ as the highest lead level in adults.

Figure 3-2 illustrates the known health effects of lead poisoning in both adults and children.

Table 3-2. How to interpret lead levels in children

Venous Confirmed Blood Lead Level ($\mu\text{g}/\text{dL}$)	Interpretation for Children Under Age 6	Action
Below 10	Child is not lead-poisoned.	No action
10-14	Child has some exposure to lead.	Community intervention activities
15-19	Child has an elevated blood lead level.	Level confirmed with second blood lead level test. Individual case management, including nutritional and educational interventions and more frequent screening. If level persists, conduct an environmental inspection and remediation.
20-44	Child is considered to be lead-poisoned.	Environmental investigation and remediation as well as items for above. Medical checkup.
Above 45	Child is seriously lead poisoned.	Medical checkup and treatment.

Based on a child's blood lead level, the public health response will differ.

Source: CDC



Figure 3-2. The effects of lead poisoning on children and adults

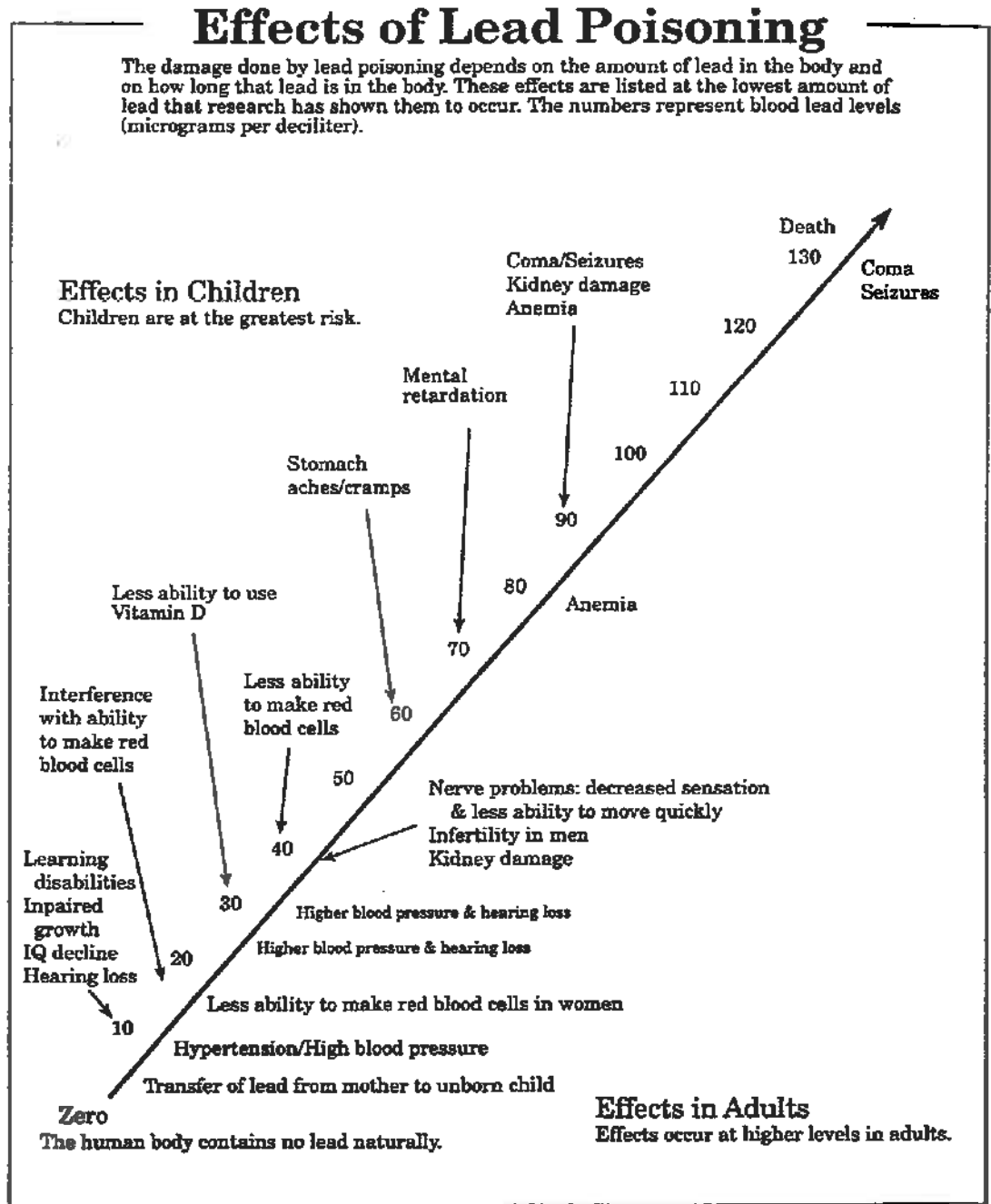

Source: Lead Elimination Action Drive, 2125 West North Avenue, Chicago, Illinois 60647



Treatment

The first step in the treatment of suspected lead poisoning is to remove the person from further exposure. Depending on the level of lead in the blood, the treatment will include some or all of the following:

- parent education
- nutrition counseling
- child evaluation
- medication.

The medications used for treating lead poisoning are known as “chelating agents.” Chelation is the process by which lead is removed from a person’s body by the use of medication. Chelating agents irreversibly bind the lead circulating in the bloodstream so that the lead is excreted through the person’s urinary system or liver and gastrointestinal tract. Chelation is used only in cases of high levels of blood lead under the care of a medical specialist, since there are serious side effects of this treatment, such as anemia. Because of these side effects, chelation should never be used as a preventive measure and is prohibited in adults by OSHA [1926.62(j)(4)(i)].

**Chelating agents
have serious side
effects.**



The first step in treating lead poisoning is to remove the person from further exposure!

Summary

The many adverse health effects of lead, the widespread opportunities for exposure, and the low levels of absorption of lead that may cause serious harm underscore the importance of workers and health-care providers being aware of the hazards of lead exposure. They can help prevent lead poisoning by understanding the hazards of lead and ensuring careful implementation of control measures. Understanding the health hazards of lead will also encourage inspectors to protect themselves and their families from excessive exposure and will enable them to answer questions from property owners or residents on the need for lead-based paint inspections.



CHAPTER 4

REGULATORY BACKGROUND

Objectives	4-3
Learning Tasks	4-4
Introduction	4-5
Legislative and Regulatory History	4-7
Differences in Regulations	4-9
Residential Lead-Based Paint Hazard Reduction Act (Title X)	4-10
Requirements for Federally Owned or Assisted Housing	4-11
Requirements for Disclosure of Known LBP and/or LBP Hazards in Housing	4-14
Training and Certification	4-17
Pre-Renovation Lead Hazard Education Rule	4-21
Health-Based Standards	4-23
Guidelines for the Evaluation and Control of Lead-Based Paint Hazards in Housing	4-24
Regulation by the Occupational Safety and Health Administration (OSHA)	4-25
Waste Disposal Under the Resource Conservation and Recovery Act (RCRA)	4-28
EPA's Drinking Water Regulations	4-30
For More Information	4-32
Appendix A: List of Sections within Title X	4-35
Appendix B: Summary of HUD's Federal Housing Regulations	4-39
Appendix C: Protect Your Family from Lead in Your Home Pamphlet	4-41



Inspecting for Lead-based Paint

A vertical line on the left side of the page, likely serving as a margin or a placeholder for a table of contents.



Regulatory Background

Objectives

The objectives of this chapter are to

- provide lead-based paint inspectors with a regulatory history and a summary of current lead regulations and guidance;
- explain how to comply with the laws regulating lead inspections and environmental sampling.



Learning Tasks

After completing this chapter, inspectors should be able to

- describe the regulatory history of lead-based paint (LBP) testing and abatement;
- explain the focus of Title X and the different regulations stemming from it;
- describe the training and certification requirements applicable to a lead-based paint inspection.

As an inspector, this section is important because

- you should have a general understanding of the regulatory requirements for testing and abatement.



Regulatory Background

Introduction

Over the last two decades the federal government has taken a number of key actions to reduce risks associated with lead exposures. The government has

- banned the use of lead in house paint;
- banned the use of lead in the solder and pipes used in public drinking water systems;
- banned the use of leaded solder in food cans (both imported and domestic);
- virtually removed lead from gasoline;
- issued new standards for drinking water;
- issued interim guidance on hazardous levels of lead in soil and household dust;
- established training and certification regulations;
- established work practice standards for lead inspections, risk assessments, interim controls, and abatement;
- implemented a lead in construction standard;
- issued guidelines for the control of lead-based paint hazards in housing.

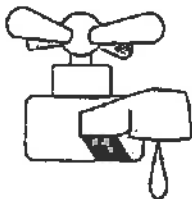
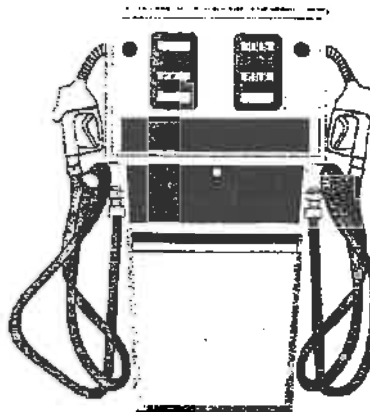

Over the last two decades the federal government has reduced the risk of lead exposure.



Inspecting for Lead-based Paint

These actions have been very effective in reducing major sources of lead exposure. Deaths from lead poisoning, which up to 20 years ago were not uncommon, have been almost eliminated. However, old lead-based paint and the associated contaminated dust and soil remain largely unchanged as environmental sources of lead. Moreover, continuing scientific research has demonstrated that harmful effects from lead may occur at lead levels previously considered safe. Experts agree that a large number of children are still at unacceptable levels of risk.



Regulatory Background

Legislative and Regulatory History

Although many cases of severe lead poisoning were reported in the United States during the first half of this century, it was not until the 1950s that public health officials in some of the larger cities began to trace the cause of many of the cases to old housing with deteriorating lead-based paint.

Below is a summary of the regulatory history of lead from the 1950s to present.

- 1950s U.S. public health officials begin to trace cases of lead poisoning to lead-based paint
- 1955 paint industry adopted a voluntary standard limiting the use of lead in interior paints to no more than one percent by weight of nonvolatile solids
- 1970 Occupational Safety and Health Act (OSHA) enacted
- 1971 Federal government enacted the Lead-based Paint Poisoning Prevention Act (LBPPPA), Public Law 91-695; Amended in 1973, 1976, 1987, and 1988 (McKinney Act). Lead-based paint was defined as paint containing more than 1.0 percent lead by weight.
- 1972 U.S. Department of Housing and Urban Development (HUD) issued regulations prohibiting the use of lead-based paint in HUD-associated housing.
- 1973 LBPPPA was amended to lower the lead content allowed in paint to 0.5 percent until 31 December 1974 and 0.06 percent after that date unless the Consumer Product Safety Commission (CPSC) found that a higher percentage was safe.
- 1974 CPSC reported to Congress that it considered 0.5 percent lead to be a safe level.
- 1976 additional amendments to LBPPPA lowered the paint lead limit to 0.06 percent unless CPSC again determined that a higher limit not exceeding 0.5 percent was safe.
- 1977 CPSC declined to make such a finding; thus, lead-based paint became defined as paint containing more than 0.06 percent as of 23 June 1977.
- 1978 CPSC, acting under the authority of the Consumer Product Safety Act, banned the sale of lead-based paint to consumers and the use of lead-based paint in residences, on other areas where consumers have direct access to painted surfaces, and on toys and furniture;
OSHA promulgated 29 CFR 1910.1025—Lead in General Industry Standard

In the 1950s the U.S. began to trace the cause of lead poisoning to old housing with deteriorating lead-based paint.

In 1978, the CPSC banned to sale of lead-based paint to consumers. They defined LBP as 0.06% by weight.



HUD required lead-based paint inspections of PHAs and IHAs by December 1994.

Congress enacted Title X in 1992.

Inspecting for Lead-based Paint

- 1986 HUD issued new regulations for all HUD housing programs that redefined "immediate hazard" and changed the construction cutoff date from 1950 to 1973 in most cases.
- 1987 Congress amended LBPPPA to require: inclusion of intact paint in the definition of immediate hazard and a construction cut off date of 1978; the inspection of a random sample of dwellings in pre-1978 family public and Indian housing developments, to be completed by 6 December 1994, and the abatement of lead hazards exceeding 1.0 mg/cm²; and an extensive research and demonstration program
- 1988 LBPPPA amendments required a comprehensive and workable plan for abatement in public housing. HUD issued new regulations in June 1988 pertaining primarily to the public housing program but also making 1978 the construction cutoff date for all programs and defining "applicable surface" to include intact paint for all programs in accordance with the act.
- 1989 a number of federal agencies, including HUD, EPA, and HHS, formed a lead task force to ensure that the regulatory efforts conducted under different statutory authorities produce a unified and coherent approach to lead pollution problems, based on a common understanding of the health data.
- 1990 HUD Interim Guidelines for Indian and Public Housing
- 1992 Title X of the 1992 Housing and Community Development Act (The Residential Lead-based Paint Hazard Reduction Act)
- 1993 OSHA promulgated 29 CFR 1926.62—Interim Final Lead in Construction Industry Standard
- 1994 EPA Guidance on Residential Lead-based Paint, Lead-contaminated Dust, and Lead-contaminated Soil
- 1995 HUD Guidelines—*Guidelines for the Evaluation and Control of Lead-based Paint Hazards in Housing*
- 1996 HUD/EPA Disclosure Rule
EPA Requirements for Lead-based Paint Activities in Target Housing and Child-occupied Facilities
- 1998 EPA Pre-renovation Lead Hazard Education Rule
- 1997 Revision to chapter 7 of the *Guidelines for the Evaluation and Control of Lead-based Paint Hazards in Housing*
- 1999 HUD 24 CFR Part 35—Requirements for Notification, Evaluation and Reduction of Lead-based Paint Hazards in Housing Receiving Federal Assistance and Federally-owned Residential Property Being Sold



Regulatory Background

Differences in Regulations

This chapter is based upon federal lead-based paint regulations and guidance. Inspectors must determine whether or not state, tribal, or local regulations conflict with federal regulations. If regulations conflict, the most stringent applicable requirements from each of the regulations must be complied with. For example, the City of Savannah, Georgia defines lead-based paint as lead concentrations, as measured by a portable X-ray fluorescence analyzer (XRF), exceeding 0.7 mg/cm^2 . This is lower than the Federal standard of $\geq 1.0 \text{ mg/cm}^2$. In this case, the inspector would follow the Savannah standard, as it is more stringent. However, the Commonwealth of Massachusetts' Lead Paint Law requires abatement of LBP only if the concentration exceeds 1.2 mg/cm^2 . In this case, an inspector engaged in housing inspections of federally assisted or associated housing would follow the federal standard of $\geq 1.0 \text{ mg/cm}^2$, as it is more stringent.



Title X switched the federal government's focus from LBP to LBP hazards.

Residential Lead-Based Paint Hazard Reduction Act (Title X)

In 1992, Congress enacted into law the Housing and Community Development Act of 1992 (Public Law 102-550). Title X ("Title Ten") of that Act, the Residential Lead-based Paint Hazard Reduction Act of 1992, is comprehensive lead-poisoning prevention legislation. It switches the focus from the presence of lead-based paint to lead-based paint *hazards*. Title X defines lead-based paint hazards as "any condition that causes exposure to lead from lead-contaminated dust, lead-contaminated soil, or lead-contaminated paint that is deteriorated or present on accessible surfaces, friction surfaces, or impact surfaces that would result in adverse human health effects as established by the appropriate Federal agency."

One section of Title X (Section 1015) mandated the formation of a task force—the Task Force on Lead-Based Paint Hazard Reduction and Financing. The task force's purpose was to develop a series of recommendations to harness private market forces and better target public resources to finance and control lead-based paint hazards in the nation's housing stock before children are poisoned.¹ Based on the recommendations from this report, EPA and HUD continued moving forward with regulations and guidance addressing the specific sections of Title X. (A list of the main components and sections of Title X is included as Appendix A of this chapter.)

Title X mandated action by many branches of the federal government to reduce lead hazards in housing.

Title X affects a number of other federal laws by amending their statutory language. As a result, the Toxic Substances Control Act (TSCA) was amended to include a new title, Title IV. Under the Toxic Substances Control Act (TSCA), Title X mandated

- training and certification of lead-based paint abatement contractors, inspectors, risk assessors, abatement workers, and project designers;
- training-provider accreditation;
- establishment of health-based standards for dust, soil, and lead-based paint;
- notification to buyers and renters of pre-1978 housing of the hazards of lead-based paint and disclosure of known LBP or LBP hazards.
- laboratory accreditation;
- performance standards for testing and abatement products;
- action to reduce the risks of creating new LBP hazards during renovation and remodeling projects.

¹"Moving Toward a Lead-Safe America: A Report to the Congress of the United States," U.S. Department of Housing And Urban Development, Office of Lead Hazard Control, February 1997.



Regulatory Background

Requirements for Federally Owned or Assisted Housing (Sections 1012 & 1013)

Title X of the 1992 Housing and Community Development Act established specific requirements for action in federally owned or associated housing (pre-1978 housing units).

On 15 September 1999 HUD published final regulations to implement sections 1012 and 1013 of Title X, which set forth specific policies on lead-based paint hazard reduction in federally assisted and federally owned housing (24 CFR Part 35—Requirements for Notification, Evaluation and Reduction of Lead-based Paint Hazards in Housing Receiving Federal Assistance and Federally-owned Residential Property Being Sold). This rule is a comprehensive amendment of previous federal housing lead-based paint regulations and consolidates the many dispersed HUD lead-based paint requirements into one part of the Code of Federal Regulations. Most of the requirements of this regulation take effect on 15 September 2000; however, the prohibitions against using dangerous methods of removing paint take effect on 15 November 1999 (see Table 4-1).

The new regulation has different requirements for different types of housing activities. These requirements vary depending on the

- nature of activity and
- the extent of federal involvement in the property.

Generally, the requirements include some form of assessment of the unit or a lead hazard evaluation (e.g., a visual assessment, limited paint testing, a paint inspection, or a risk assessment) followed by lead hazard reduction (paint stabilization, interim controls, or abatement) and clearance. For example,

- in housing receiving tenant based rental assistance, a visual assessment and paint stabilization is required
- in properties receiving project-based assistance, a risk assessment followed by interim controls is required.

When residential units are sold by the federal government, Title X mandates an inspection and abatement of lead-based paint hazards in residential properties constructed prior to 1960 and an inspection and disclosure of lead-based paint hazards for properties constructed between 1960 and 1978. (See Appendix B for a summary of all requirements organized by activity.)

In all cases where work is performed in a unit, safe work practices are required.





Table 4-1. Methods of paint removal prohibited by HUD (24 CFR 35.140)

Prohibited Methods of Paint Removal

- ⇒ open flame burning or torching
- ⇒ machine sanding or grinding without a high-efficiency particulate air (HEPA) local exhaust control
- ⇒ abrasive blasting or sandblasting without HEPA local exhaust control
- ⇒ heat guns operating above 1,100 degrees Fahrenheit, or those that operate high enough to char the paint
- ⇒ dry sanding or dry scraping*
- ⇒ paint stripping in a poorly ventilated space using a volatile stripper that is a hazardous substance or chemical

* Four exceptions to this prohibition are: (1) dry scraping in conjunction with heat guns; (2) dry scraping within 1.0 foot (0.20 meters) of electrical outlets; (3) treating deteriorated paint spots that total no more than two square feet (0.2 square meters) in any one interior room or space; or (4) treating deteriorated paint spots that total no more than 20 square feet (two square meters) on exterior surfaces.



Regulatory Background

Safe work practices are defined in the rule (Sec. 35.1350) as:

- **prohibited methods**—methods of paint removal listed in Sec. 35.140 (see Table 4-1) shall not be used.
- **occupant protection and worksite preparation**—occupants and their belongings shall be protected, and the worksite prepared, in accordance with Sec. 35.1345.
- **specialized cleaning**—after hazard reduction activities have been completed, the worksite shall be cleaned using cleaning methods, products, and devices that are successful in cleaning up dust-lead hazards, such as a HEPA vacuum or other method of equivalent efficacy, and lead-specific detergents or equivalent.
- **de minimis levels**—“safe work practices” (that is, occupant protection, worksite preparation, and specialized cleaning) must be used during stabilization or abatement only when the area of paint being disturbed is greater than:
 - ◆ 20 square feet on exterior surfaces; or
 - ◆ 2 square feet in an interior room; or
 - ◆ 10 percent of a building component with a small surface area (examples include window sills, baseboards, and trim).

Appendix B provides an expanded summary of the requirements of this regulation.



The disclosure rule was jointly issued by EPA and HUD.

The disclosure applies to sales and rentals of most pre-1978 housing.

Requirements for Disclosure of Known LBP and/or LBP Hazards in Housing

One provision of Title X directly imposes requirements on owners of private housing. The joint EPA and HUD regulation was published 6 March 1996 and is titled *Requirements for Disclosure of Known Lead-Based Paint and/or Lead-Based Paint Hazards in Housing* (40 CFR Part 745 and 24 CFR Part 35). The rule became fully effective on 6 December 1996. The rule requires the following before a purchaser or lessee of housing built before 1978 (i.e., target housing²) is obligated under any contract:

- the seller or lessor (landlord) shall provide the purchaser or lessee an EPA-approved lead hazard information pamphlet (*Protect Your Family from Lead in Your Home* [see Appendix C]);
- the seller or lessor (landlord) shall disclose to the purchaser or lessee *and* each agent the presence of any known lead-based paint or lead-based paint hazards in the target housing being sold or leased. Additionally, the seller or lessor must provide a copy of any records or reports and disclose any additional information available concerning the LBP or LBP hazards (e.g., basis for the determination that LBP or LBP hazards exist, location of LBP or LBP hazards, condition of the painted surfaces). This requirement includes common areas.;
- the sales/rental contract shall include a lead warning statement and a statement signed by the purchaser or lessee, the seller and lessor, and agents (the language that must be used is shown on the following pages);
- the purchaser shall be given at least 10 days (unless the parties mutually agree, in writing, upon a different period of time) to conduct a risk assessment or inspection (this last item applies *only* to sales of target housing).

Housing exempted from the disclosure rule

Some types of pre-1978 housing units are exempted from the disclosure rule. These exemptions include:

- target housing sold at foreclosure;
- zero-bedroom units (e.g., barracks, dormitories, studio apartments, lofts);²
- short-term rentals (100 days or less);

²Target housing is defined as "any housing constructed prior to 1978, except housing for the elderly or persons with disabilities (unless any one or more children age 6 years or under resides or is expected to reside in such housing for the elderly or persons with disabilities) or any 0-bedroom dwelling.



Regulatory Background

- housing specifically for the elderly or handicapped, unless any one or more children age 6 years or under resides or is expected to reside in such housing;
- housing for lease that has been inspected and found to be LBP-free by a certified inspector or risk assessor.

Whenever a seller or lessor enters into a contract with an agent, the agent shall ensure that this regulation is complied with.

This regulation introduces the term "lead-based paint free." For the purposes of this rule, EPA and HUD have defined lead-based paint free housing as target housing that has been found to be free of paint or other surface coatings that contain lead equal to or in excess of 1.0 milligram per square centimeter or 0.5 percent by weight. Owners of rental properties that are found to be LBP-free are exempted from the lead disclosure requirements. This LBP-free exemption is applicable only to rental of target housing and not to the sale. If a LBP-free rental dwelling is subsequently sold, all the provisions of this rule would again apply.

The lead-based paint free exemption applies only to rental properties.



Required Lead Warning Statements

Target Housing Sales Contracts

Lead Warning Statement

Every purchaser of any interest in residential real property on which a residential dwelling was built prior to 1978 is notified that such property may present exposure to lead from lead-based paint that may place young children at risk of developing lead poisoning. Lead poisoning in young children may produce permanent neurological damage, including learning disabilities, reduced intelligence quotient, behavioral problems, and impaired memory. Lead poisoning also poses a particular risk to pregnant women. The seller of any interest in residential real property is required to provide the buyer with any information on lead-based paint hazards from risk assessments or inspections in the seller's possession and notify the buyer of any known lead-based paint hazards. A risk assessment or inspection for possible lead-based paint hazards is recommended prior to purchase.

Target Housing Lease Contracts

Lead Warning Statement

Housing built before 1978 may contain lead-based paint. Lead from paint, paint chips, and dust can pose health hazards if not managed properly. Lead exposure is especially harmful to young children and pregnant women. Before renting pre-1978 housing, lessors must disclose the presence of known lead-based paint and/or lead-based paint hazards in the dwelling. Lessees must also receive a federally approved pamphlet on lead poisoning prevention.



Regulatory Background

Training and Certification (Section 402 and 404 of Title X)

EPA has issued regulations governing the training and certification of lead professionals (*Requirements for Lead-Based Paint Activities in Target Housing and Child-Occupied Facilities*, 40 CFR Part 745, 29 August 1996). The rule establishes work practice standards and specific criteria for certifying lead professionals and accrediting training providers, including prerequisites and minimum training required for the certified disciplines involved in evaluating and controlling residential lead-based paint hazards. This regulation applies to target housing and child-occupied facilities. Child-occupied facilities are defined as

a building, or portion of a building, constructed prior to 1978, visited by the same child, six years of age or under, on at least two different days within any week, provided that each day's visit lasts at least three hours, the combined weekly visit lasts at least six hours, and the combined annual visits last at least 60 hours. Child-occupied facilities may include, but are not limited to, day-care centers, preschools, and kindergarten classrooms.

The federal regulations do not require LBP inspections, risk assessments, or abatement in target housing or child-occupied facilities; rather, should the owners/operators of these facilities conduct these activities, the companies and individuals involved must be trained and certified, and follow prescribed work practices. These requirements went into effect in all states and Indian Nations that have not already enacted similar legislation on 1 March 2000.

Certification of individuals

The rule covers a contractor who offers to abate a home of lead-based paint hazards, or an inspector who offers to conduct a lead-based paint inspection in a residential dwelling. The work practice standards are not intended to regulate all activities that involve or disturb lead-based paint, but only those that are described as an inspection, risk assessment or abatement by an individual who offers these services. This rule does not regulate a renovation contractor that incidentally disturbs lead-based paint (See Pre-renovation Notification Rule later in this chapter) or an individual who samples paint on a kitchen cabinet to determine if the paint contains lead.

The rule recognizes five work disciplines:

- inspector
- risk assessor
- supervisor



EPA issued training, certification, and work practice standards rules for lead professionals.

Both individuals and firms must be certified or licensed.



abatement worker

project designer

Table 4-2 illustrates the differences between the disciplines and the lead-based paint activities each discipline may perform under the Federal program.

For information regarding state or tribal authorization status, contact the National Lead Information Clearinghouse (see *For More Information* section on page 4-31). While many state and tribal programs were modelled after the federal program, some have significant differences including the disciplines requiring certification/licensing; the education and experience prerequisites; recertification requirements; and others. Inspectors should contact each state or Indian tribe in which they plan to work to determine the requirements for obtaining certification or licensing.

Certification of firms

The rule requires firms that perform or offer to perform any of the LBP paint activities included in Table 4-2 to also be certified. The firm must submit to either the state, Indian tribe, or EPA a letter attesting that the firm will only employ appropriately certified employees to conduct LBP activities and that the firm and its employees will follow the work practice standards in Sec. 745.227 for conducting LBP activities.

Recertification

To maintain certification in a particular discipline, a certified individual must apply to the state, Indian tribe, or EPA and successfully complete a one-day training course (project designers must complete a half-day training course) and exam from an accredited training provider. The federal regulation includes two time frames for fulfilling this requirement:

- every three years if the individual completed a training course with a course test and hands-on assessment (most training courses meet this definition);
- every five years if the individual completed a training course with a proficiency test (a course that relies on testing the student's ability to conduct the activities related to the discipline [e.g. having inspector students do an inspection of a dwelling and determine how close to the real lead levels they came]).

Refresher training must be completed every three years, or more often if required by the state or Indian tribe.

Regulatory Background

Table 4-2. Training and Certification Requirements based on 40 CFR Subpart L

Discipline	Definition	Education/Experience Prerequisites
Inspector	trained by an accredited training program and certified to conduct LBP inspections and collect samples for the presence of lead in dust and soil for the purposes of abatement clearance testing.	none*
Abatement Worker	trained by an accredited training program and certified to perform abatements	none
Project Designer	trained by an accredited training program and certified to prepare abatement project designs, occupant protection plans, and abatement reports	successful completion of supervisor's course and <i>one</i> of the following: <ul style="list-style-type: none"> • BS or BA in engineering, architecture, or related profession, and one year experience in building construction and design or a related field • four years of experience in building construction and design or a related field
Risk Assessor	trained by an accredited training program and certified to conduct risk assessments. A risk assessor also samples for the presence of lead in dust and soil for the purposes of abatement clearance testing.	successful completion of an inspector's course and <i>one</i> of the following: <ul style="list-style-type: none"> • BS or BA plus one year experience in a related field** • an Associates degree and two years experience in a related field** • certification as an industrial hygienist, professional engineer, registered architect and/or certification in a related engineering/ health environmental field (e.g. safety professional, environmental scientist) • high school diploma or equivalent and at least three years of experience in a related field**
Supervisor	trained by an accredited training program and certified to supervise and conduct abatement projects, and to prepare occupant protection plans and abatement reports.	one of the following: <ul style="list-style-type: none"> • one year of experience as a certified LBP abatement worker • at least two years of experience in a related field** or in building trades

* to become certified, must pass a third party exam administered by the state, Indian tribe, or EPA.

**e.g., lead, asbestos, environmental remediation work, or construction



All LBP activities in target housing and child-occupied facilities must follow the work practice standards.

Inspectors must follow documented methodologies when conducting a LBP inspection.

Inspectors must check with their state or Indian tribe to determine if the requirements differ from EPA.

Work practice standards

Effective in all states and Indian nations that do not have their own regulations by 1 March 2000, all lead-based paint activities in target housing and child-occupied facilities must be performed according to the work practice standards outlined below:

- must use certified individuals for all LBP activities;
- must follow documented methodologies found in
 - HUD *Guidelines*
 - EPA Guidance on Residential LBP, Dust, and Soil
 - EPA Residential Sampling for Lead: Protocols for Dust and Soil Sampling (EPA report number 7474-R-95-001)
 - regulations, guidance, methods or protocols issued by States and Indian tribes that have been authorized by EPA
 - other equivalent methods and guidelines (e.g., ASTM);
- clearance levels, when referenced, found in the EPA guidance on residential LBP, dust, and soil or in other equivalent guidelines.

These standards provide specific requirements for conducting inspections (discussed in detail in Chapter 7), risk assessments, abatement projects (including soil), and postabatement clearance sampling. Within the abatement section there are requirements for

- notification to the appropriate state or Indian tribe agency, or EPA prior to beginning the project;
- a written occupant protection plan
 - unique to each residential dwelling or child-occupied facility, and
 - written by a certified supervisor or project designer;
- restricted abatement practices (e.g., open-flame burning, sanding or abrasive blasting without HEPA exhaust control);
- an abatement report, which is prepared by a certified supervisor or project designer;
- collection and analysis of environmental samples.



Regulatory Background

Pre-Renovation Lead Hazard Education Rule

Through Title IV of TSCA, Congress directed EPA to address the public's risk of exposure to lead-based paint hazards through regulations, education, and other activities. Of particular concern to Congress were potential lead exposure risks that could occur during renovations of housing containing lead-based paint. Therefore, EPA issued the Lead-based Paint Pre-Renovation Education Rule (40 CFR Part 745). This rule, which went into effect on 1 June 1999, requires renovators to distribute the pamphlet *Protect Your Family From Lead in Your Home* to owners and occupants of most pre-1978 residential housing before beginning renovations. The goal of this rule is to raise consumer awareness of risks posed by renovation of homes with lead-based paint. Specifically, the rule requires pamphlet distribution if



- the renovation job is for compensation (e.g., money, goods, or services);
- the renovation activity will disturb more than 2 ft² of painted surfaces.

This rule applies to all renovation activities in target housing, including activities by contractors who may not consider themselves "renovation contractors," e.g., plumbers, drywallers, painters, electricians. If these professionals disturb more than 2 ft² of paint, they must comply with this rule. Work that is performed for free (i.e., no exchange of money, goods, or services) or work performed by do-it-yourselfers in their own home is not covered by this rule. Work that is performed during an emergency is also excluded from this rule.

Pamphlets must be delivered using one of the following procedures. For owner-occupied units:

- provide pamphlet to the owner and get written acknowledgment of receipt; or
- mail pamphlet to the owner seven days prior to renovation; document with certificate of mailing (i.e., written verification from the US Postal Service).



The pre-renovation education rule raises consumer awareness of risks of disturbing lead-based paint.

This rule applies if more than 2 ft² of paint will be disturbed in target housing.



Inspecting for Lead-based Paint

For tenant-occupied units:

- provide pamphlet to both owner and an adult occupant using one of the methods listed above for owner-occupied units;
- get signature of both the owner and an adult occupant documenting receipt.

If an adult occupant is unavailable to sign an acknowledgment of receipt, or refuses to sign the acknowledgment form, the renovation contractor may leave the pamphlet at the unit and prepare certification describing delivery attempts.

If renovation activities are to occur in a common area (e.g., laundry room, hallway, playground) of housing with more than four separate dwelling units, the contractor must provide *all* units of the building with a notice containing *information on the timing and extent of the renovations slated to occur*. When renovation activities will only occur in common areas, individual acknowledgment of receipt of renovation notices is not required. The contractor need only document renovation notice distribution procedures for his/her files.

EPA has developed both a question and answer document (June 1998) and interpretative guidance for contractors, property managers, and maintenance personnel on how to comply with this rule. Both documents are available on EPA's web page (www.epa.gov/lead).



Regulatory Background

Health-Based Standards

Under section 403 of TSCA, EPA is developing a rule that will identify conditions of lead-based paint and lead levels and conditions in residential dust and soil that may result in a hazard to building occupants, especially children age 6 and under. In combination with the work-practice standards described previously, the levels and conditions identified in the TSCA section 403 rule should provide clear direction on how to identify, prioritize, and respond to hazards from lead in and around target housing.

In the interim, EPA has published guidance to assist the public in identifying LBP hazards, sources of lead exposure, and the need for control actions in environments where children may be present.

EPA originally issued this guidance in a 14 July 1994 memorandum entitled "Guidance on Residential Lead-based Paint, Lead-contaminated Dust, and Lead-contaminated Soil" and subsequently published it in the *Federal Register* (60 FR 47248). More information on this guidance is included in Chapter 8, *Soil Sampling for Lead Contamination*, and Chapter 9, *Dust Sampling for Lead Contamination*.

Title X requires EPA to issue health-based standards for lead in dust, soil and deteriorated paint.



Guidelines for the Evaluation and Control of Lead-Based Paint Hazards in Housing

The 1990 *Interim Guidelines for Public and Indian Housing* were revised substantially and replaced in June 1995 by the HUD *Guidelines for the Evaluation and Control of Lead-Based Paint Hazards in Housing*. The 1995 *Guidelines* consist of 18 chapters and 16 technical appendices. These *Guidelines* supersede and replace the *Interim Guidelines*. They cover a broad spectrum of housing types and categories of ownership.

The 1995 *Guidelines* address the full range of activities involved in evaluating and controlling lead-based paint hazards, as introduced in 1992 by Title X. The *Guidelines* provide detailed, comprehensive technical information on how to identify lead-based paint and related hazards in housing and how to control such hazards safely and efficiently. The 1995 *Guidelines for the Evaluation and Control of Lead-based Paint Hazards in Housing* included a revised protocol for conducting lead-based paint inspections (Chapter 7). In 1997, after two years of use, this protocol was refined further and provides the basis for much of this course.

The purpose of the *Guidelines* is to "help property owners, government agencies, and private contractors sharply reduce childhood exposure to lead without unnecessarily increasing the cost of housing." Although the *Guidelines* are lengthy, familiarity with them is essential for persons engaged in testing or abating lead-based paint or evaluating lead-based paint hazards in housing. Many state licensing and certification programs refer to the procedures for inspections, abatement, risk assessments, and environmental sampling that are included in the *Guidelines*.

Copies of the HUD *Guidelines* are available from HUD USER at 800/245-2691 or can be downloaded from HUD's Office of Lead Hazard Control's home page on the internet (www.hud.gov/lea).

The HUD *Guidelines* address identifying, evaluating, and controlling lead-based paint hazards in housing.





Regulation by the Occupational Safety and Health Administration (OSHA)

Lead in Construction Standard

The original lead standard issued by OSHA was the standard for lead exposure in general industry. In 1971 OSHA set a Permissible Exposure limit (PEL) of 200 micrograms of lead per cubic meter of air ($200 \mu\text{g}/\text{m}^3$). A PEL is the maximum worker exposure level to a contaminant. OSHA promulgated a new Lead Standard (29 CFR 1910.1025) in 1978 for all industries except construction and agriculture. The revised standard lowered the PEL to $50 \mu\text{g}/\text{m}^3$. The standard was designed to regulate workplace exposures to lead that are generally consistent, since conditions and work practices remain fairly constant in general industry (e.g., battery manufacturing plant). Lead-based paint abatement and inspections are considered construction activities.

In 1990 the National Institute for Occupational Safety and Health (NIOSH) set a national goal to eliminate worker exposures resulting in blood lead concentrations greater than 25 micrograms per deciliter ($25 \mu\text{g}/\text{dL}$) of whole blood. This prompted OSHA to initiate the development of a proposal for a comprehensive standard regulating occupational exposure to lead in construction. When Congress passed Title X, it required OSHA to issue an interim final lead standard for the construction industry to be effective until a final standard is issued.

The standard regulating lead exposure in the construction industry was issued in May 1993 (*Interim Lead in Construction Standard*, 29 CFR 1926.62). Under this standard, regulating occupational exposure to inorganic lead in the construction industry (which includes construction, alteration, and/or repair, including painting and decorating), the PEL is $50 \mu\text{g}/\text{m}^3$ as an 8-hour time-weighted average (TWA). The standard requires monitoring the lead level in the worker's blood (blood lead level [BLL]) for workers exposed to airborne lead at or above the Action Level of $30 \mu\text{g}/\text{m}^3$ (8-hour TWA), and specifies medical removal of workers whose average BLL based on two consecutive tests is $50 \mu\text{g}/\text{dL}$ or greater.

Some states have their own occupational safety and health plans, which must be at least as stringent as federal OSHA rules. Inspectors should check with the state in which the work is to be done for state OSHA regulations that could be more stringent and have wider coverage.

Respiratory Protection Standard

Inspectors may need to wear respiratory protection in an effort to further minimize their exposure to lead dust. Selection of the appropriate level of respiratory protection should include

OSHA

OSHA's interim lead in construction standard established a PEL of $50 \mu\text{g}/\text{m}^3$ and an action level of $30 \mu\text{g}/\text{m}^3$.



Inspecting for Lead-based Paint

If respirators are worn, the employer must comply with 29 CFR 1910.134.

- identification of the hazards;
- evaluation of the hazards;
- provision of respirators protective against the contaminant level(s) and suitable for the wearer.

Whenever respiratory protection is worn by employees, the employer must comply with the OSHA Lead in Construction Standard [29 CFR 1926.62(f)]. Employers who provide respirators to their employees must have a written respiratory protection program in accordance with 29 CFR 1910.134 (b), (d), (e), and (f). The respirator program should include at a minimum, the following elements:

- written standard operating procedures;
- medical surveillance;
- training;
- fit testing;
- inspection, cleaning, maintenance, and storage;
- employee surveillance (surveillance of work areas and exposures);
- respirator program evaluation.

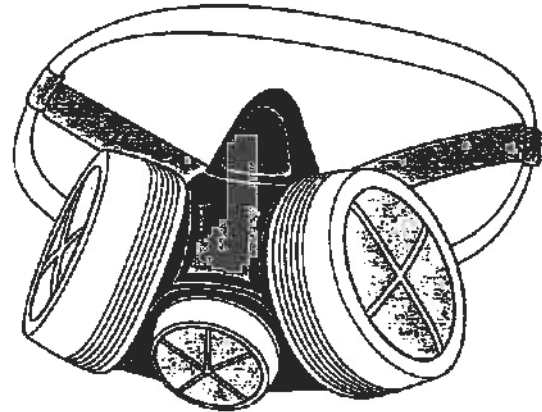

Inspectors must be medically qualified, fit tested, and trained in order to wear respiratory protection. Employers must perform either qualitative or quantitative fit tests for each employee wearing negative and positive pressure tight-fitting respirators. Fit testing is to be performed at the time of the initial fitting and at least annually thereafter.

Respirators must carry a National Institute of Occupational Safety and Health (NIOSH) approval number. NIOSH is the official respiratory testing and certification agency for respiratory protection. "TC" which stands for "tested and certified" precedes each approval number

Inspectors must be medically qualified, fit tested, and trained in order to wear respiratory protection.

If lead is present in a workplace in any quantity, the employer is required to make an initial determination of whether any employee's exposure to lead exceeds the action level of 30 ug/m³ averaged over an 8-hour day. Employee exposure is that exposure which would occur if the employee were not using a respirator. This initial determination requires the employer to monitor workers' exposures unless the employer has objective data that can demonstrate conclusively that no employee will be exposed to lead in excess of the action level. Where objective data is used in lieu of actual monitoring, the employer must establish and maintain



Regulatory Background

an accurate record, documenting its relevancy in assessing exposure levels for current job conditions. If such objective data is available, the employer need proceed no further on employee exposure assessment until such time that conditions have changed and the determination is no longer valid.

However, if this initial determination shows that a reasonable possibility exists that any employee may be exposed, without regard to respirators, over the action level, the employer must set up an air monitoring program to determine the exposure level representative of each employee exposed to lead in the workplace.

The employer is required to determine if any employee's exposure to lead exceeds the action level of 30 $\mu\text{g}/\text{m}^3$ averaged over an 8-hour day.



Waste Disposal Under the Resource Conservation and Recovery Act (RCRA)

The basic federal law governing waste disposal is the Resource Conservation and Recovery Act (RCRA) of 1976. RCRA was amended in 1980 and again in 1984 by the Hazardous and Solid Waste Amendments (HSWA). HSWA brought smaller waste generators (e.g., Public Housing Administrations [PHAs] conducting LBP abatement) under RCRA regulation for the first time.

RCRA governs federal hazardous-waste disposal regulations. It distinguishes between solid and hazardous waste and defines hazardous waste and hazardous-waste generators. It provides information on required procedures to be followed before, during, and after disposal. Treatment, storage, and disposal facilities (TSDs) and waste transporters are described. While RCRA governs federal hazardous-waste disposal regulations, states regulate solid (nonhazardous) waste. Many states run their own hazardous-waste programs with EPA approval under RCRA. However, some states, and even some localities, have more stringent rules than RCRA. Thus, all individuals involved with lead-based paint abatement projects (including inspectors) should become familiar with all state and local waste disposal rules and the ways in which these rules differ from RCRA.

The basic philosophy that should be adopted by all involved parties is minimization of waste production. This philosophy prevents waste products from entering the environment. Employing good control measures during abatement and cleanup and using proper procedures for storing and handling waste help to minimize waste. LBP abatements produce potentially large quantities of solid waste, such as

- building components;
- sludges from paint stripping;
- lead paint chips and dust;
- waste water from cleanup;
- used protective clothing and filters;
- plastic sheeting used for containment.

Some of these waste materials are hazardous because of their corrosiveness or because of leachable lead in the paint. Typically, waste must be tested to determine if it is hazardous. All involved parties (including inspectors) should understand how to determine what wastes are hazardous and how to dispose of both hazardous and solid wastes in a safe and cost-effective manner. Chapter 10, Appendix 10, and Appendix 10.1 of the HUD *Guidelines* provide information on proper waste disposal. Waste disposal questions should be directed to the state agency



RCRA governs federal hazardous waste disposal regulations.

Many states and Indian Tribes run their own hazardous waste program under RCRA.



Regulatory Background

responsible for enforcing RCRA. Federal EPA also has an RCRA/ Superfund Hotline at 1-800-424-9346 (202-260-3000 in Washington, D.C.).

In December 1998, EPA published a proposed rule under the Toxic Substances Control Act (TSCA) for the management and disposal of LBP debris generated by individuals or firms. In another document in the 18 December 1998 *Federal Register*, EPA also separately proposed to suspend temporarily the applicability of regulations under Subtitle C of RCRA which currently apply to LBP debris. These proposed rules would suspend current hazardous waste management requirements for disposal of LBP debris and allow disposal of LBP debris in construction and demolition (C&D) landfills. EPA analysis found disposal in C&D landfills to be safe (i.e., protective of human health and the environment) and less costly than disposal in other types of landfills. *Until a final version of this rule is published, the current state, Indian tribe, or EPA solid and hazardous waste requirements apply to lead-based paint abatement debris.*

Note that even if abatement waste is not classified as hazardous under EPA regulations, it may still be contaminated with lead dust. Thus, care should be taken by all parties to avoid contaminating the environment or exposing children to lead dust. For example, practices such as stockpiling debris in the yard of a dwelling must be avoided.



EPA's Drinking Water Regulations

Drinking water is the largest remaining source of lead over which EPA has direct regulatory control. In 1986 Congress banned the use of lead-containing materials in public water supply systems and in any plumbing providing drinking water connected to public water systems. All 50 states adopted this ban. The major plumbing codes in the United States were revised to exclude the use of materials containing lead in potable water applications.

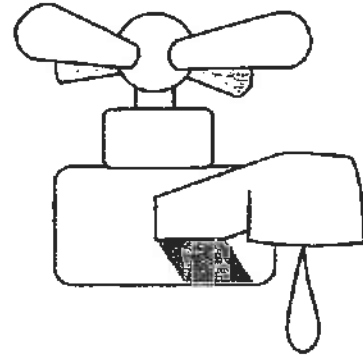

Among the materials prohibited by law in public water supply systems are solder and flux containing more than 0.2 percent lead and other plumbing materials containing more than 8 percent lead. However, illegal use of lead-containing solder apparently continues. Also, experience indicates that considerable amounts of lead can leach from brass plumbing products, even though they contain 8 percent lead or less.

In November 1988 a new amendment to the Safe Drinking Water Act, known as the Lead Contamination Control Act of 1988 (LCCA), became law. It requires that the EPA develop a guidance document and that the states establish programs to help schools and day-care centers to test for and remedy lead contamination in drinking water from water coolers and other sources of lead. The LCCA also contains specific requirements for the testing, recall, repair, and/or replacement of water coolers with lead-lined storage tanks or with parts containing lead. The LCCA also establishes civil and criminal penalties for the manufacture and sale of water coolers containing lead.

In June 1991 under authority of the 1986 Safe Drinking Water Act (SDWA), EPA's Office of Ground Water and Drinking Water promulgated the "National Primary Drinking Water Regulation for Lead." They require 79,000 public water-suppliers to monitor tap water in hundreds of thousands of dwellings across the country. Based on this monitoring, water treatment techniques may need to be adjusted. The goal of the new standards is for at least 90 percent of monitored household drinking water taps to have lead levels of 15 parts per billion (ppb) or less, which corresponds to an average level of approximately 5 ppb. (Drinking water lead concentrations are highest in tap water.) This regulation also sets a Maximum Contaminant Level Goal (MCLG) of zero for lead in drinking water. MCLGs are nonenforceable, optimal health-based targets.

As mandated by the Safe Drinking Water Act Amendments of 1996, the law prohibits any person from introducing into commerce any pipe, plumbing fitting or fixture that is not lead free after 6 August 1998. Lead free as defined in the SWDA means that solders and flux may not contain

Lead free as defined by SWDA:
Solder/flux: > 0.2%
Other materials:
> 8.0%

Public water suppliers are not responsible for plumbing inside private housing.

Level of concern for lead in drinking water is 15 ppb.



Regulatory Background

more than 0.2 percent lead, and pipes, pipe fittings, and well pumps may not contain more than 8.0 percent lead.

Since public water suppliers are not responsible for plumbing inside private housing, EPA encourages the public to let tap water run for 30-60 seconds (collect it in a bucket and use it, for example, for watering plants that are not used for food) before using it for cooking or drinking.

Individuals may also want to test their water for lead. Households that have lead levels above 15 ppb in a 1 liter sample should take the following steps to limit lead exposure:

- running tap water for 30-60 seconds before use;
- never using water from the hot water tap for drinking or cooking;
- not boiling water longer than necessary for making baby formula;
- checking for lead solder.

To obtain further information on lead in drinking water, call EPA's Drinking Water Hotline at 1-800-426-4791 or by electronic mail at hotline-sdwa@epamail.epa.gov. Additional information is also available at EPA's Office of Groundwater and Drinking Water Internet web site at <http://www.epa.gov/ogwdw>.

If lead contamination is likely, let tap water run for 30-60 seconds before using for drinking or cooking.



For More Information

These publications and agencies can provide more information on the topics covered in this chapter.

Lead; Requirements for Hazard Education Before Renovation of Target Housing; Final Rule, 40 CFR Part 745, U.S. Environmental Protection Agency, 1998.

Lead; Requirements for Lead-Based Paint Activities in Target Housing and Child-Occupied Facilities; Final Rule, 40 CFR Part 745, U.S. Environmental Protection Agency, 1996.

Lead; Requirements for Disclosure of Known Lead-Based Paint and/or Lead-Based Paint Hazards in Housing; Final Rule; 40 CFR Part 745 and 24 CFR Part 35, U.S. Environmental Protection Agency and U.S. Department of Housing and Urban Development, 1996.

Lead Exposure in Construction; Interim Final Rule, 29 CFR 1926.62, U.S. Department of Labor, Occupational Safety and Health Administration, 1993.

Requirements for Notification, Evaluation and Reduction of Lead-Based Paint Hazards in Federally Owned Residential Property and Housing Receiving Federal Assistance; Final Rule, 24 CFR Part 35, et al. U.S. Department of Housing and Urban Development, 1999.

The Guidelines for the Evaluation and Control of Lead-based Paint Hazards in Housing, U.S. Department of Housing and Urban Development, 1995 (rev. 1997).

The Residential Lead-Based Paint Hazard Reduction Act of 1992, Pub. L. 101-550; 42 U.S.C. 4851.

Federal agencies

Consumer Product Safety Commission (CPSC)
 Washington, DC 20207-0001
 800-638-2772
 Web site: www.cpsc.gov

Department of Housing and Urban Development (HUD)
Office of Lead Hazard Control
 451 7th Street, S.W.
 Washington, DC 20410
 202-755-1785
 Web site: www.hud.gov/lea



Regulatory Background

Department of Labor
Occupational Safety and Health Administration (OSHA)
200 Constitution Avenue, N.W.
Washington, DC 20210
202-693-2000
Web site: www.osha.gov

Environmental Protection Agency (EPA)
Office of Pollution Prevention and Toxics
401 M Street, S.W.
Washington, DC 20460-0003
202-260-2090
Web site: www.epa.gov/lead

National Lead Information Center
800-424-LEAD
Web site: www.epa.gov/nlic

Inspecting for Lead-based Paint



Appendix A: List of Sections within Title X



Inspecting for Lead-based Paint



Regulatory Background

Appendix B: Summary of HUD's Federal Housing Regulations



Inspecting for Lead-based Paint

1

Regulatory Background

List of Sections Within Title X
LBP Hazard Reduction

Section 1011	HUD	Grants for LBP Hazard Reduction in Housing
Sec 1012	HUD	Evaluation and Reduction of LBP Hazards in Federally Assisted Housing
Sec 1013	HUD	Disposition of federally Owned Housing
Sec 1014	HUD	Comprehensive Housing Affordability Strategy
Sec 1015	HUD	Task Force on LBP Hazard Reduction and Financing
Sec 1016	HUD, HHS, EPA	National Consultation on LBP Hazard Reduction
Sect 1017	HUD	Guidelines for LBP Hazard Evaluation and Reduction Activities
Sec 1018	EPA, HUD	Disclosure of information concerning lead upon transfer of residential property

Lead Exposure Reduction

Note: This subtitle is comprised of section 1021 which amends the Toxics Substances Control Act (TSCA) by adding a Title IV to the act that contains the following sections:

Sec 402	EPA	LBP activities training and certification
Sec 403	EPA	Identification of dangerous levels of lead
Sec 404	EPA	Authorized State Programs
Sec 405	EPA, NIEHS, NIOSH, NSC, NIST	Lead abatement and management
Sec 406	EPA	Lead hazard information pamphlet and renovation regulations

Inspecting for Lead-based Paint

Worker Protection

Sec 1031	OSHA	Worker Protection
Sec 1032	EPA, DOL	Coordination between EPA & DOL
Sec 1033	NIOSH, EPA	Grants for training workers and supervisors and evaluation of programs

SUBTITLE D: Research and Development

Sec 1051	HUD, EPA	Research on lead exposure from other sources
Sec 1052	HUD, EPA, NIST	Research on testing technologies and hazard reduction methods
Sec 1056	GAO	Federal implementation and insurance study

Regulatory Background

Appendix C: *Protect Your Family from Lead in Your Home Pamphlet*

Inspecting for Lead-based Paint





CHAPTER 5

THEORY AND USE OF X-RAY FLUORESCENCE (XRF) ANALYZERS

Objectives	5-3
Learning Tasks	5-4
Introduction	5-5
X-ray Fluorescence Theory	5-7
Health Effects of XRF Radiation	5-13
Radiation Safety	5-14
Radiation Monitoring	5-19
Leak Testing	5-20
Types of XRF Analyzers for Lead-based Paint Testing	5-21
<i>Performance Characteristics Sheets</i>	5-21
Substrate Bias and Correction	5-23
Substrate Correction Protocol	5-25
Field Quality Control Procedures	5-26
Accuracy, Precision, and Bias	5-26
Calibration Checks	5-28
Standard Reference Materials	5-30
Licensing and Registration of XRF Analyzers	5-31
Specific Licenses	5-32
Reciprocity	5-33
General Licenses	5-34
XRF Training	5-35
Transportation	5-36
XRF Analyzer Record Keeping	5-39
Appendix A: Calibration Check Test Results Form	5-41



Inspecting for Lead-based Paint





Theory and Use of X-Ray Fluorescence (XRF) Analyzers

Objectives

The objectives of this chapter are to

- provide inspectors with a working knowledge of X-ray fluorescence technology;
- describe the basic operating principles of portable XRF analyzers;
- introduce how XRF analyzers are used to conduct lead-based paint inspections;
- introduce the principles of radiation safety;
- explain registration and licensing requirements of XRF instruments.



Learning Tasks

After completing this chapter, inspectors should be able to

- explain the XRF method of testing for lead in paint;
- list at least five issues related to safely using an XRF analyzer;;
- describe the similarities and differences between instruments.

As an inspector, this section is important to you because

- correct use of an XRF analyzer requires an understanding of the theory behind it;
- your own safety and the safety of others at test sites depend upon proper handling of the instrument;
- accurate test results require a thorough knowledge of the capabilities and limitations of the XRF analyzer you will use.



Theory and Use of X-Ray Fluorescence (XRF) Analyzers

Introduction

A number of methods are used to test for the presence of lead in paint, soil, and dust. Since the scope of the lead problem is so great and the costs of abating lead are high, it is important to determine accurately whether lead is present in a sample (i.e., painted wall surface, wood trim, soil, or dust wipe sample) and whether the lead level exceeds regulatory limits. In addition, since the ability of a piece of equipment to detect lead is highly dependent upon the skill of the operator of the instrument, the operator must understand how the equipment works. A trained operator will take preventive measures to verify that the instrument is operating properly before, during, and after the testing. If something should go wrong during the inspection, the operator must take immediate, corrective action to remedy the problem. Failure to use the instrument properly could also cause revocation of an inspector's license/certification.

Like all analytical methods, the methods used for lead detection are subject to some degree of error, even after all possible precautions have been taken. The task of the inspector is to account for these errors and to arrive at defensible decisions on the presence or absence of lead-based paint or the need for further testing.

Two basic types of error are possible in lead-based paint testing:

- a false negative (failure to detect lead at or in excess of the federal regulatory standard);
- a false positive (concluding that lead is present at or above the federal regulatory standard when, in fact, it is not).

The two error types have different practical consequences. A false negative results in the failure to detect lead or a lead hazard, with the potential for poisoning a resident child; a false positive may result in unnecessary implementation of hazard controls such as abatement.

X-ray fluorescence (XRF) is one analytical technique used for lead detection. XRF analyzers use this technique to determine the presence and the amount of lead in a sample. XRF analyzers present information in two general ways and are classified by that characteristic:

- direct reader
- spectrum analyzer.

The inspector must understand how the XRF works to obtain accurate results.

Two types of XRFs:

- direct reader
- spectrum analyzer



Inspecting for Lead-based Paint

Several different brands of portable XRF instruments are commercially available. While similar in the way they operate and are handled, the two general categories of portable analyzers have some important differences. The following sections describe the:

- underlying theory behind the operation of XRF analyzers;
- potential hazards of using these instruments improperly;
- similarities and differences between the two categories of analyzers currently on the market.



Theory and Use of X-Ray Fluorescence (XRF) Analyzers

X-ray Fluorescence Theory

An XRF analyzer works by exposing a paint surface to radiation emitted from a sealed source inside the instrument. The source of this radiation in all the XRF analyzers currently used for lead-based paint inspections is the cobalt-57 (^{57}Co) isotope or the cadmium-109 (^{109}Cd) isotope. Both of these radioactive materials spontaneously emit energy in the form of X rays and gamma rays.

When these rays are released from an XRF analyzer and hit a painted surface, the elements in the paint matrix—which can include lead—are “excited” and respond by emitting energy in the form of X rays

characteristic of each of the elements (see Figure 5-1). This response is known as *fluorescence*. An

example of one type of fluorescence is what occurs with a “black light.” When a black light shines on certain paint surfaces (just like the rays emitted by the XRF), the paint absorbs the black light and then glows or gives off a visible light (i.e., fluoresces) and is seen by the viewer’s eyes (our “detector”).

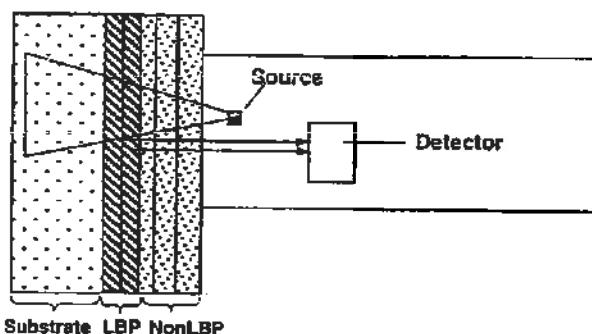

Figure 5-1. XRF emitting gamma and X rays and analyzing characteristic X rays from paint and substrate

Basic Atomic Theory

To understand how X-ray fluorescence works, a basic understanding of the structure of an atom is necessary. Atoms are the basic building blocks of all things. A simplistic view of an atom is to compare it to the earth’s solar system. The nucleus of an atom is represented by the sun and the orbiting electrons are represented by the planets (see Figure 5-2). The electrons rotate around the nucleus in orbits. The closer the orbit of the

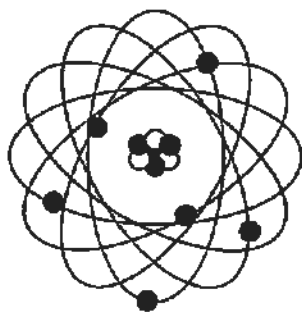

Figure 5-2. Basic structure of an atom

electron is to the nucleus, the more tightly bound those electrons are to the atom. This is because the nucleus of the atom is made up of positively charged particles (protons) and, except for hydrogen, neutrons—which carry no electrical charge. The orbiting electrons are negatively charged particles. Just as with a magnet, positive attracts negative.

The different orbits (called “shells”) in the atom are labeled sequentially with

Fluorescence is the emission of X rays by elements in the paint or substrate.

Atoms have electrons that rotate in orbits or shells around a nucleus.



Inspecting for Lead-based Paint

Gamma or X-rays can "knock" an atom's electrons out of orbit.

letters starting with K, L, M, N, O, P, etc. Every shell of a stable atom contains a fixed number of electrons; the total number of electrons depends upon the element. The K shell is closest to the nucleus; therefore the electrons in this shell are the most tightly bound to the atom. Going outward in the electron shells, electrons are more loosely bound, and thus are more easily ejected from their orbit or shell.

Gamma or X rays with sufficient energy can knock an atom's electrons out of orbit. The electron then becomes a "free electron." When an electron is ejected from an atom, another electron from a higher shell "drops down" to fill the vacancy. Atoms prefer to maintain a neutral charge. When an electron is knocked out of orbit, the atom carries a positive charge until the atom attracts one of the free electrons to balance the charge.

The electrons of the K shell are of lower energy; therefore, the bond to the nucleus is the greatest. The electrons of the L shell, M shell, etc. are of higher energy and are therefore not as tightly bound to the shell. When an outer shell electron jumps to an inner shell (e.g., an M or N shell electron jumps down to the L shell) since less energy is required to maintain that lower energy orbit and thus the leftover energy is emitted by the atom as a *characteristic X ray*. These are the X rays which are analyzed by the detector within the XRF analyzer.

When an electron is ejected from its shell, the vacant shell is usually filled by an electron from another shell in step-wise fashion. For example, when a K shell electron is emitted, an L shell electron jumps into its place and creates a subsequent vacancy in the L shell. Similarly, the L shell vacancy is filled by an M shell electron, with the simultaneous emission of the characteristic L X ray of that element. This process continues to the outer shells in such a way that when K X rays are generated, L, M, N (and so on) X rays are also emitted. This cascading effect does not have to be initiated at the K shell. It can start at the L, M, or higher shells (see Figure 5-3). It's possible for a K-shell vacancy to be filled by an M-shell electron, rather than an L-shell electron. In that case

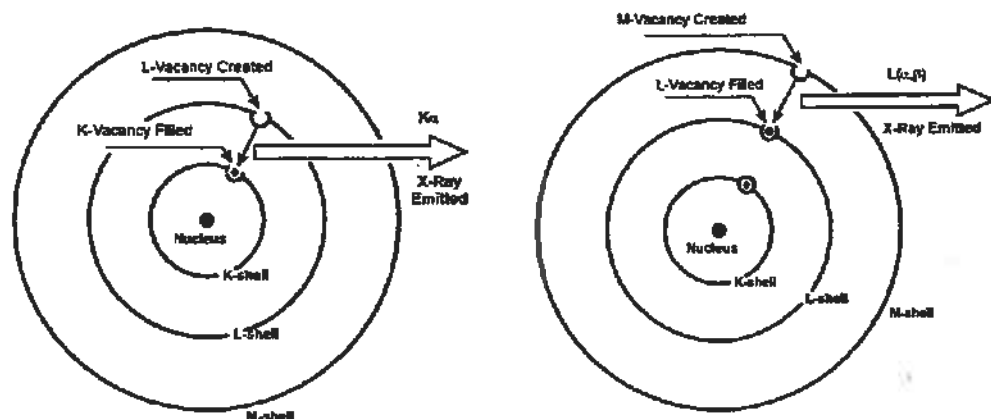

Figure 5-3. Illustration of electron shell vacancies and filling



Theory and Use of X-Ray Fluorescence (XRF) Analyzers

the X ray emitted is still called a K X ray (because the initial vacancy occurred in the K shell). Each time a vacancy is filled by an electron from another shell, a different energy X ray is emitted. The characteristic X rays of differing energies emitted from each element that are detected by a portable XRF analyzer are labeled using the Greek letters alpha (α), beta (β), and gamma (λ). The Greek-letter labeling is used to identify from which shell the replacement electron originated (e.g., if the replacement electron came from the L shell, it is called a $K\alpha$ X ray, while if it came from the M shell, the resulting X ray is called a $K\beta$).

The energy required to “knock out” a K shell electron increases with the atomic number of the element. Therefore, the heavier the element, the more energy needed to create an electron vacancy in the K shell (so we can generate K X rays) and the higher the energy of the gamma or X ray must be in order to cause this effect. Most commercially available XRFs are designed to generate gamma rays of sufficient energy to knock out the K shell electrons and induce the atom to generate characteristic K X rays from lead.

X rays are similar in nature to radio waves, in that both are part of the electromagnetic wave spectrum. X rays, like radio waves, are given off in different frequencies. X rays from lead have a different frequency than X rays from any other element (e.g., zinc or chromium). All XRF analyzers must address the same technical problem of deciding which of the X rays detected are from lead atoms and which X rays are from other elements within the paint or the substrate.

Consider what happens while you are driving a car from Atlanta, Georgia, to the east coast. While listening to your favorite Atlanta rock and roll station on the car radio, as you get further away from Atlanta you begin to also receive a country and western station from Columbia, South Carolina.

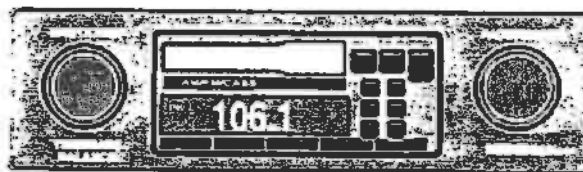

No matter how you tune your radio, you are unable to separate the two stations. This is because the radio signal emitted by the two stations is close enough in intensity and frequency to be heard on the same channel. Eventually, as you get closer to Columbia, you lose the Atlanta station entirely. The strength of the signal from Atlanta is no longer strong enough to be received by your radio.

In the same manner as radios separate frequencies, most XRFs separate the X rays by energy. The terms *spectrum* and *direct read* do not describe how an XRF detects and separates X rays, but rather how the information is displayed to the user. Most XRFs use a multichannel analyzer to separate the different energy X rays emitted by the painted surface and the substrate. This is based on the principle that X rays of different frequencies are of different energies. In fact, an X ray's

X-rays and radio waves are both part of the electromagnetic wave spectrum.

X-rays of different energies are separated by a multichannel analyzer.



Inspecting for Lead-based Paint

Lead atoms emit X rays whose energies are unique to lead.

frequency is directly related to its energy. When an X ray strikes the detector of an XRF it creates an electrical impulse or "signal" within the detector. The higher the energy, the more intense the electrical impulse. The machine *counts* the number of times it receives an electrical impulse at each channel. Since each channel represents a different energy, and each energy represents a different element's X rays, the number of counts is proportional to the amount of each element present within the paint or substrate. Thus, each time a gamma ray "excites" a lead atom, the atom fluoresces or emits X-rays at an energy unique to lead. The analyzer has a detector that monitors these emissions and, when properly calibrated, computes the amount of lead in the sample. If the concentration of lead is high, more lead atoms are hit by the gamma rays emitted by the radioactive source within the XRF analyzer. Thus, a larger number will register on the digital display located on the instrument. The quality of the data is determined by the resolution (i.e., ability to differentiate between energies) of the multichannel analyzer and the electronics of the instrument.

A spectrum contains peaks at the energy levels of the most abundant elements in a sample.

In short, an X ray emerges from the sample and enters the detector. The detector and electronics of the XRF analyzer convert the X-ray energy into an electrical pulse whose amplitude is proportional to the energy. The overall pulse amplitude range is divided into channels. The computerlike memory of the analyzer then stores the pulses in channel numbers according to amplitude. Since the detectors are less than perfect, the pulse amplitudes may vary slightly for a given energy, so not all pulses for a specific energy fall into a single channel. The result is a peak which is symmetrically distributed over several channels. This energy distribution is often presented on the analyzer's display in the form of a "spectrum" (graph), where the X axis is the energy and the Y axis is number of counts (intensity). The center channel of the peak is taken to represent the energy that identifies the element from which the X ray came. The height of the peak (intensity) is related to the concentration of the element. Depending on the radioactive source and the detector used, the spectrum will display peaks representing K or L X rays, including the alpha, beta or gamma subsets of those X rays. If a particular element is not present in the sample, the corresponding region of the spectrum will be displayed as flat or very low. Figure 5-4 illustrates a L X-ray spectrum of lead, where the X axis has been calibrated in terms of X-ray energy, rather than channel number. A properly trained operator can view the screen and determine whether the XRF analysis is being affected by backscatter or by interference from X rays of other elements.

It is not necessary to classify and store all the X rays of different energies detected by the detector within the XRF. Since the X rays of interest in an inspection are lead

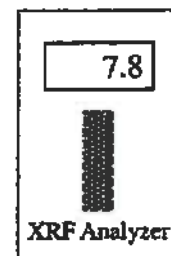

Sample direct reader display

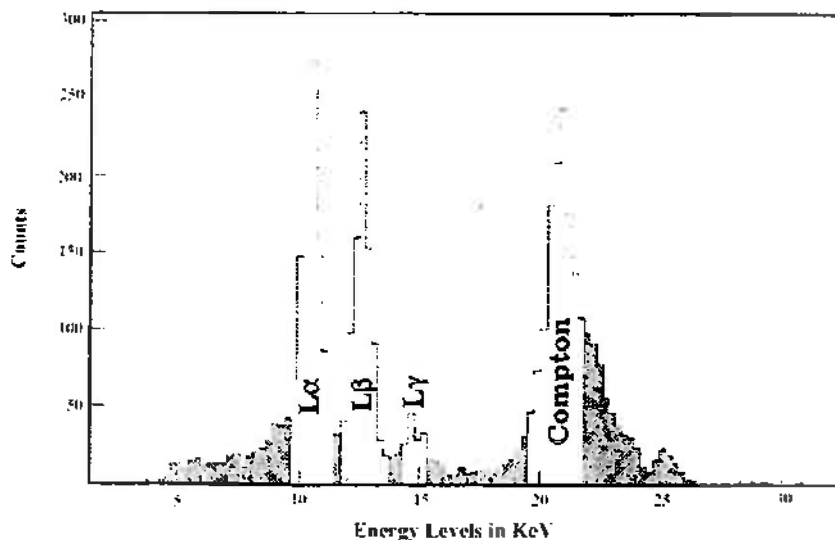

Figure 5-4. Example of an L X-ray spectrum of lead-based paint

X rays, some XRF analyzers use the energy levels of the characteristic lead X rays to filter and process only those pulses corresponding to lead. This is the detection analysis method employed by direct reading XRF analyzers.

Half-life

The cobalt-57 or cadmium-109 isotopes give off gamma and X rays at all times. Since the intensity of this emission decreases over time (“decay rate”), the radiation source in the XRF analyzer must be replaced periodically so that the instrument remains capable of detecting lead in a sample in a reasonable amount of time.

Each radioactive element decays at a specific rate. Decay refers to the spontaneous transformation of a radioactive element into another element, which may or may not be radioactive (e.g., cobalt-57 over time converts to an isotope of iron). The term *half-life* refers to the time it takes *half* of the material to decay into another radionuclide or element. The amount of time that it takes for an XRF analyzer to determine if lead is present is related to the number of source atoms that decay and emit gamma and X rays during sampling. After one half-life, the length of time it takes to obtain a proper reading doubles. Today’s XRFs normally correct automatically for source decay by extending the length of time of a reading.

The half-life for cobalt-57 is approximately 9 months and for cadmium-109 is approximately 15 months. For example, a reading that takes five seconds initially will take ten seconds nine months after a cobalt-57 source is installed by the manufacturer into an XRF analyzer. Therefore, the older the source, the longer it will take to conduct an inspection using

A direct reading XRF displays only the lead level.

The radiation source of an XRF must be replaced periodically.

Approximate half life for ⁵⁷Co is 9 months and for ¹⁰⁹Cd, 15 months.



Inspecting for Lead-based Paint

an XRF analyzer. Some instruments have been programmed so that if the source is more than a prescribed age, the instrument will not take readings. This forces the owner to get a new source. The cost of re-sourcing an XRF varies by manufacturer and source strength, but is approximately \$1000 to 3500 per source, which includes factory calibration. You are advised to contact the manufacturer before shipping the instrument for re-sourcing to ensure that a source is available. Because the sources decay whether in an instrument or not, it is not cost effective for a manufacturer to have sources sitting on the shelf waiting for a buyer. Likewise, an instrument owner will be paying for source decay whether or not the instrument is being used for paint inspections.

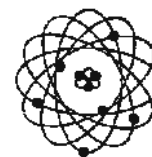

Theory and Use of X-Ray Fluorescence (XRF) Analyzers

Health Effects of XRF Radiation

X rays and gamma rays, unlike radio waves, are dangerous, because they carry a great deal of energy. Since XRF analyzers emit gamma rays, XRF analyzers can be dangerous to their users and to those in the direct path of the analyzer's emissions if the analyzer is not used properly.

The very reason that X rays are useful in measuring levels of different elements makes them dangerous to our bodies. Gamma and X rays are forms of *ionizing radiation*. Radiation that has enough energy to eject electrons from electrically neutral atoms, leaving behind charged atoms or *ions*, is known as ionizing radiation. The result of ionization is the production of *negatively charged* free electrons and *positively charged* ionized atoms. There are four types of ionizing radiation that can be classified into two groups:

- 1) photons, such as gamma and X rays, and
- 2) particles, such as beta particles (positrons or electrons), alpha particles (similar to helium nuclei), and neutrons (particles with zero charge, electrically neutral).

All types of ionizing radiation can remove electrons. Ionized atoms, regardless of how they were formed, are much more active chemically than neutral atoms. These chemically active ions can form compounds that interfere with the process of cell division and metabolism. Also, reactive ions can cause a cascade of chemical changes in the tissue. Chemical and physical changes from exposure of humans to ionizing radiation can lead to a variety of cancers. The degree of damage suffered by an individual exposed to ionizing radiation is a function of several factors:

- type of radiation involved;
- chemical form of the radiation;
- intensity of the radiation flux (related to the amount of radiation and distance from the source);
- energy;
- duration of exposure.

Fortunately, the amount of radiation involved with any of the XRF analyzers is small and, with proper use, will expose the inspector to very low amounts of radiation. However, inspectors should understand the overall health effects of radiation and, with that knowledge, strive for safest possible use of the instrument.

Ionizing radiation can be dangerous.

Gamma and X rays are forms of ionizing radiation.

The amount of radiation exposure when using XRF analyzers is small.



Always handle an XRF analyzer with care.

You must be trained to use an XRF!

The XRF instrument must be controlled by the inspector or RSO at all times.

Radiation Safety

Since the XRF analyzer contains a sealed source of radioactivity, inspectors must handle the analyzer with great care. The radiation source is held in a metal capsule with a beryllium or thin stainless steel window. Thus, the emissions from this source are *shielded* to minimize the operator's exposure. When the instrument is properly used, the radiation exposure is minimal. However, the operator must be fully aware of the proper operation of the instrument and the potential for radiation exposure. This discussion is not intended to be alarming. Rather, it should encourage inspectors to take the use of the instrument very seriously.

Basic common sense dictates that the inspector adhere to the following rules of operation:

- No one should operate an XRF analyzer until they have received thorough training.
- Always handle the analyzer carefully, since some radiation is given off even when the instrument is not in use.
- **Never point the shutter of an XRF analyzer at yourself or any other person.** When the XRF device is used on a wall that adjoins another room or dwelling (such as in an apartment or other multiple-unit dwelling), the inspector must check to be certain that no one is in the adjoining space. X rays, and especially gamma rays, can go through solid objects like wood or plaster.
- Under no circumstances should the XRF analyzer be positioned in such a way that you expose eyes or genitals to direct radiation from the instrument.
- Never open the shutter unless testing a surface.
- The XRF instrument must be in your control at all times, either in direct sight or in an area designated secure by the company's radiation safety officer (RSO). The inspector is responsible for the security of the radioactive source.
- Children are likely to be curious about a device that, in some cases, resembles a gun and is used in their surroundings. Therefore, if children are in the unit, the inspector or another trained person must maintain constant control over the instrument so that children or others do not touch or tamper with the device in any way.
- If an XRF is lost, it must be reported **immediately** to state authorities!

Radiation is pervasive in our environment. Every person on earth is exposed to cosmic radiation, although people living in different parts of the world experience different intensities of such radiation. While one might initially believe that all radiation is harmful, there are many very



Theory and Use of X-Ray Fluorescence (XRF) Analyzers

important beneficial uses of radiation. For example, radiation is used for medical and dental diagnosis. These exposures to radiation have been carefully studied and analyzed to ensure that they are well below levels that might be harmful to a human being.

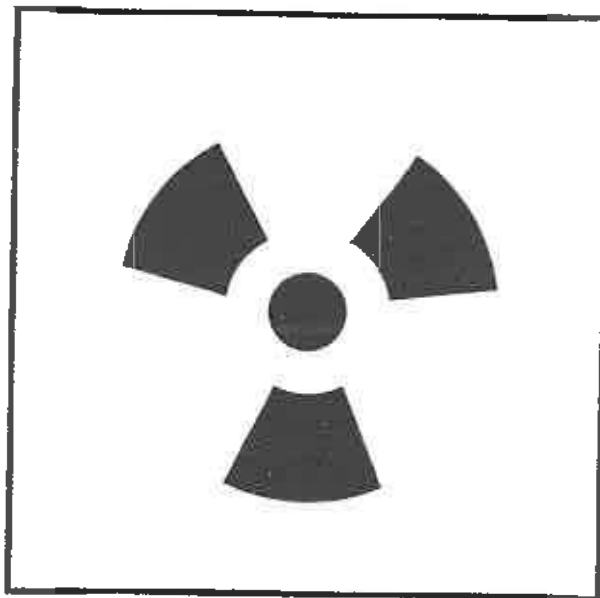

Standard radiation symbol
(black or magenta symbol on a yellow or white background)

Measuring Radiation Exposure

The quantity of ionizing radiation exposure is measured in *roentgens*. The units of dosage are measured in *roentgen equivalent man (rem)* or one-one thousandths of a rem (*millirem* or *mrem*). The higher the dosage the greater the potential for adverse health effects. Since all XRF analyzers produce some exposure to the human body, you have a right to know how much radiation any particular XRF will give off while you are using it. This information must be supplied by the manufacturer in its literature and during the manufacturer's training. Remember that the dosages that are quoted are based upon proper use of that particular XRF.

Natural Background Sources of Radiation

Natural background radiation is the largest contributor (about 300 mrem/yr) to an individual's total radiation dose. The main sources of natural background radiation are:

- radon, a naturally occurring gas
- cosmic radiation (i.e., radiation from the sun and outer space)

Everyone on earth is exposed to naturally occurring radiation.

The units of dosage of ionizing radiation are measured in *roentgen equivalent man (rem)*.

Natural background radiation is the largest contributor to an individual's total radiation dose.



- radioactive elements, such as thorium and uranium, present in the earth's crust
- radioactive elements, such as ⁴⁰potassium, present in the human body and in building materials, including cinder block (cement block).

Human-made Sources of Radiation

Human-made sources of radiation contribute to the remainder of the annual average radiation dose (about 60 mrem).

Examples of human-made sources of radiation include:

- medical X rays and nuclear medicine
- consumer products such as smoke detectors, lantern mantles, and tobacco
- fallout from nuclear weapons testing
- nuclear reactors for power generation.

Whenever you are exposed to a chemical or radiological hazard in the work place, regulatory standards and guidelines exist to protect both the employer and employee. Two separate agencies have established exposure limits, the Nuclear Regulatory Commission (NRC) and OSHA. Which levels apply to an inspector depends upon whether the firm or agency is covered by federal or state OSHA. However, NRC allowable exposure limits are universally applied, even if NRC doesn't have jurisdiction over the specific radioactive source. The standards for this type of ionizing radiation have been established as:

	Limits established by NRC	Limits established by OSHA
Whole body	5 rem per year [5,000 millirem (mrem) per year]	1.25 rem/quarter
Extremities	50 rem per year (50,000 mrem per year)	18.75 rem/quarter
Eye	15 rem per year (15,000 mrem per year)	
Fetus	0.5 rem for the gestation period (500 mrem for the gestation period)	

**Regulatory
standards for
radiation exist to
protect you!**

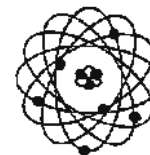

Theory and Use of X-Ray Fluorescence (XRF) Analyzers

These standards are *maximum* allowable dosages for occupationally exposed employees and they can carry health consequences. The occupational hazard of receiving the full dosage year after year may still lead to cancer, but at what is considered to be acceptable levels of three workers in 100,000. Accepting the potential risks of working with ionizing radiation is a personal matter. Each individual must weigh the benefits against the potential risks. Upon accepting the risks, each individual must respect radiation and work safely with and around it. It is your duty to yourself and your coworkers to reduce the risk by minimizing the exposure.

An inspector's exposure will vary based on how many days an XRF is used, what type of XRF instrument is used, and how many hours are spent using an XRF. To give you an example of an inspector's radiation exposure, an experienced lead-based paint inspector who has been conducting inspections using various portable XRF analyzers since 1978 was asked what his radiation exposure has been. His average annual lifetime exposure was 0.02 rem. This included a result of 0.05 rem/hour as a high for a calendar year and 0.05 rem as a high for a quarter. It is not uncommon for XRF operators to receive annual exposures which are not measurable above background. Table 5-1 provides exposure levels for various occupations as a comparison.

Occupation	Dose (mrem/yr)
Airline flight crew member	About 1,000
Nuclear power plant worker	700
Grand Central Station worker	120
Medical personnel	70
University radiation worker	<10
Lead inspector using XRF	20

Table 5-1. Average annual radiation dose for various occupations*

Most people do not have excessive exposures to radiation outside of the types just mentioned, although people who work in industries in which radioactive materials are used can experience somewhat higher exposures. However, since in any particular situation the possibility of an accident or misuse of the radioactive material exists, inspectors who may be working with radioactive materials need to understand the health effects of an overdose of radiation.

*From University of California—Santa Cruz Radiation Awareness Training Program.

Respect radiation
and work safely
with and around it.

XRF analyzers are
safe if handled
properly.



Time, shielding, and distance must be used to reduce exposure to radiation.

Factors that Affect Radiation Exposure

There is an overriding principle of radiation safety called **ALARA**.

As

Low

As

Reasonably

Achievable

The basic principle of radiation safety involves accepting the fact that all exposure to radiation cannot be eliminated.

Exposure to radiation is affected by three important factors:

- time
- distance
- shielding

The longer the exposure *time* to the radiation, the more chance there is of damage to human tissues. However, a very large dose over a short period of time is generally considered more damaging than the same cumulative dose of radiation spread out over a very long time.

The *distance* from the radioactive source is a second factor that affects radiation exposure. The intensity of radiation diminishes very quickly with the distance between the person and the radiation source. The intensity is reduced by the square of the distance from the source. Thus, a person 10 feet from the source will receive one one-hundredth the exposure compared to 1 foot from the source ($10^2 = 100$, vs. $1^2 = 1$). Therefore, distance is your best friend when it comes to minimizing exposure.

Finally, *shielding* can be one means of reducing exposure for any type of radiation. If a dense substance, such as lead or concrete, is placed between the X ray source and an exposed individual, much of the radiation is absorbed by the barrier. This is why, for example, patients receiving dental X rays have their bodies shielded with a lead blanket.

Understanding how these three factors affect the amount of radiation to which a person may be exposed can assist inspectors in complying with the basic safety procedures in using XRF analyzers. In the XRF analyzers currently acceptable for lead-based paint testing, either a trigger or a key opens a shutter that allows the radiation to escape. Even with the shutter closed, a very small amount of radiation is emitted. Therefore, if the instrument is not in use, inspectors should keep it in its storage case (which provides some additional shielding and distance). When the inspector is at the office, the XRF should always be stored at a safe distance and in its storage case.

Always store the instrument in its case and in a secure location when not in use.



Theory and Use of X-Ray Fluorescence (XRF) Analyzers

Radiation Monitoring

Even when radioactive material is being used in as safe a manner as possible by the inspector, the possible risk of exposure requires that inspectors be proactive in protecting themselves. Therefore, inspectors who use an XRF analyzer should always wear a dosimeter. Many states *require* that dosimeters be used, sometimes based on how many hours per year are spent operating the XRF analyzer. A dosimeter is a small device, usually containing a photographically sensitive or thermoluminescent material, that measures and records the amount of radiation to which the device, and therefore the person wearing it, is exposed. These badges should never be stored with the instrument or left in the sun (e.g., on the dashboard of a car).

The two basic types of dosimeters are rings and badges. The ring is worn on the finger and the badge is affixed to a piece of clothing on the torso. The dosimeter is worn by the person at all times during potential exposure to radiation at work. At the end of a discrete period of time, usually one month or one quarter (three months), the dosimeter is returned to the dosimeter service from which it was obtained. They will evaluate the amount of exposure that the individual has received and provide a report. Any overexposure recorded on the dosimeter should be reported to the Radiation Safety Officer of the inspector's company and the XRF manufacturer.

A dosimeter measures your exposure to radiation.

Report any overexposure to your company's Radiation Safety Officer.

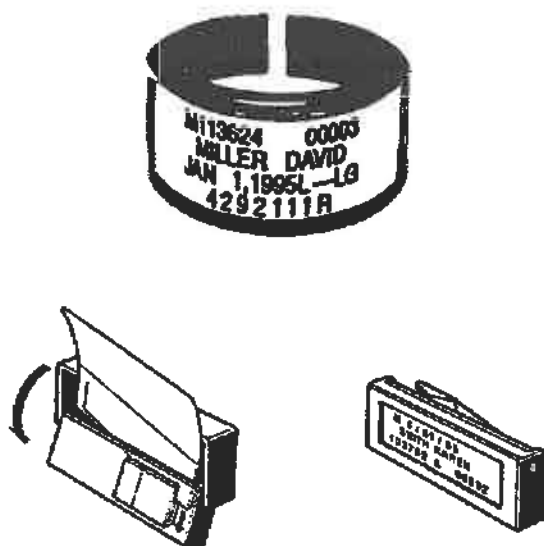

Example of a ring dosimeter (top) and a film badge (bottom).

Graphics courtesy of Landauer, Inc.



A wipe test to check for leakage of radioactive material should be taken every six months.

Leak Testing

In addition to the use of a dosimeter, qualified personnel (usually the RSO of your company) should monitor the XRF analyzer itself. Such personnel should check the instrument periodically with a radiation survey meter, such as a Geiger counter, for leakage of radiation.

Every *six months* a surface wipe should be taken on the exterior of the XRF and analyzed for radioactive levels. (NOTE: This wipe sampling is NOT the same as the sampling for lead contaminated dust!) It is performed to test for a possible breach of the sealed source within the instrument. The manufacturer's instructions for the XRF analyzer will contain information on how qualified personnel can perform these monitoring tasks and where they can send samples for analysis. The result of this test is another important document that must be kept with the XRF analyzer at all times. A separate copy should also be maintained elsewhere. Leak test result documentation is strictly enforced.



Radiation survey meter used for measuring radiation



Theory and Use of X-Ray Fluorescence (XRF) Analyzers

Types of XRF Analyzers for Lead-based Paint Testing

As explained earlier in this chapter, the two types of portable XRF analyzers are direct readers and spectrum analyzers. Most XRFs are portable, weighing less than about two kilograms (approximately 4.5 pounds). Each instrument has a digital display, operates from a battery source, and comes with a battery charger.

Direct readers display only the calculated lead concentration; most spectrum analyzers also produce a graph, called an energy spectrum, to help resolve discrepancies in the readings due to interference of substrate materials below the paint surface (for example, wood or plaster). A direct reader is like a radio with only one station (frequency). The spectrum analyzer offers a range of stations (or frequencies).

Another difference between different types of XRF analyzers lies in the internal correction of the reading for interference from the substrate. All XRF analyzers attempt to correct for substrate effects. The spectrum analyzer is more sophisticated than the direct reader, since it utilizes information from the complete energy spectrum to make the internal correction. The internal correction of both types of analyzers can be imperfect, and additional correction for substrate interference may be necessary for some instruments on some substrates.

As discussed previously, portable XRF instruments expose the painted surface to X rays or gamma rays, which causes the lead atoms to emit X rays with a characteristic energy. The intensity of this radiation is measured by the instrument's detector and is then converted into a number that represents the amount of lead in the paint per unit area, usually milligrams per square centimeter (mg/cm^2). The result will appear on the display area of the instrument and is called an XRF reading.

Performance Characteristics Sheets

The *XRF Performance Characteristics Sheet* (PCS) provides information necessary to conduct an inspection of lead-based paint using specific XRF instruments. HUD recommends using only those XRF instruments for which an *XRF Performance Characteristics Sheet* has been developed by HUD and EPA. The PCS provides detailed information regarding XRF readings taken on specific substrates, calibration check tolerances, and information describing the performance of each instrument for specific models of XRF instruments.

XRF instruments differ in that some detect K X rays, L X rays, or both. L X rays have lower energy than K X rays. As a result, L X rays released from greater depths within the paint are more likely to be absorbed before reaching the surface and are less likely to be seen by the instrument. Therefore, depending upon the number and thickness of the

XRF readings may need to be corrected for substrate bias.

XRF results are reported in mg/cm^2 .

Performance Characteristics Sheets provide important information on how to use a specific XRF for testing.



Some XRFs analyze K X rays, L X rays, or both to detect lead in paint.

paint layers, XRF instruments may have more difficulty quantitatively detecting L X rays than K X rays. Since lead is often found in primer and older paint layers, XRF measurements based on L X rays alone may underestimate the amount of lead in paint. The failure to detect X rays originating in the deeper layers of paint can be a source of error.

Instruments using K X rays also have some degree of error, since they can penetrate deeply and "see" materials behind the paint, such as nails or pipes. This deeper penetration also generates more backscatter effects from the substrate. (A discussion of substrate effects and backscatter is found in the next section.) However, most if not all of the newer generation XRF analyzers are able to compensate for this effect.

The advantages of XRF testing are

- speed (results are immediately available)
- cost-efficiency (as compared to laboratory analysis)
- non-destructiveness (the painted surface is not damaged by XRF testing).

However, XRF measurements *may* have a relatively large margin of error compared to laboratory analysis, and XRF instruments should not be used to test highly curved or ornate surfaces due to safety concerns, poor reliability of results, and inability to place the XRF analyzer flush against the surface. To deal with these problems, laboratory analysis of paint-chip samples by a laboratory recognized by the National Lead Laboratory Accreditation Program (NLLAP) is recommended. If paint-chip samples are collected, the work practice regulations of EPA, states, and Indian tribes *require* that a laboratory recognized by NLLAP be used to analyze the samples. Additional information on how to collect paint-chip samples is located in Chapter 7; additional information about sample analysis and accredited laboratories is located in Chapter 11.

If an XRF cannot measure the lead in paint, you must take a paint chip sample.

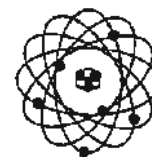

Substrate Bias and Correction

The measurement of lead in paint by any XRF analyzer is affected by scattering of X rays and gamma rays from the material that the paint covers (the substrate). Once X rays are generated from within an atom they are emitted in all directions (Figure 5-5).

Therefore, only those X rays which are emitted in the direction of the detector unit will be detected. The portion of all X rays emitted from an atom which is detected depends upon the size of the detector and its distance from the sample. The closer the detector is to the sample and the larger its size, the larger the portion of X rays detected from those emitted by the sample.

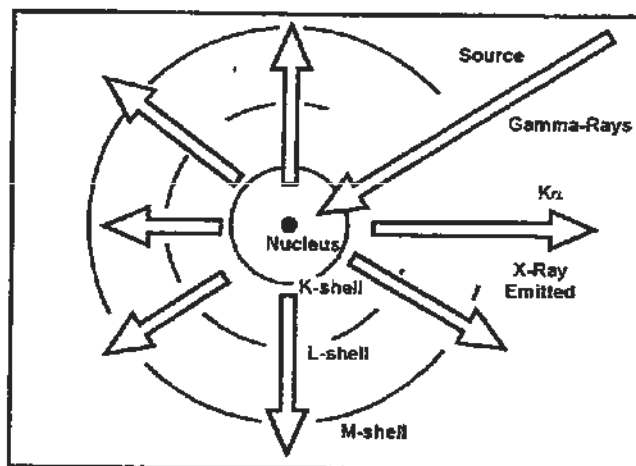

Figure 5-5. Illustration of X-rays being emitted in all directions

In addition to knocking out electrons and creating X rays, the gamma and X rays from the source can bounce off the other electrons and scatter all around the atom. Sometimes when the source radiation bounces off electrons, it loses some energy, scatters back, and is seen by the detector mixed with the X rays from the different elements in the sample. (See Figure 5-6.) This backscattered source radiation can have the same energy as the lead X rays that must be counted in order to determine the lead quantity in the paint. Counting backscatter together with lead

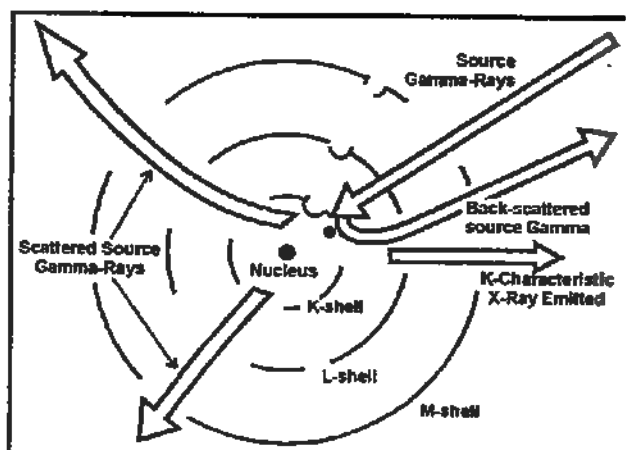

Figure 5-6. Scattering of the source gamma rays

Some of the source radiation bounces off other electrons and loses energy—this is called backscatter.

Backscattered X rays can have the same energy as lead and be counted as lead X rays.



Interference from the substrate can bias an XRF measurement high or low.

X rays results in an overestimation of lead concentration, unless you can account for it and subtract its contribution from the data.

Accounting for backscattering interference would be less important if this contribution was the same for all materials (paint, wood, metal, etc). However, not all substrate materials backscatter with the same intensity. Portable XRF analyzers use different methods, with varying degrees of success, to account for this interference.

Interference from the substrate can bias the measurement high (measurement overestimates the true lead level) or low (measurement underestimates the true lead level). This interference is inherent in the physics of X ray fluorescence, not dependent upon the type or manufacturer of the XRF analyzer. Research conducted by the National Institute of Standards and Technology (NIST) and HUD demonstrates that all XRF instruments exhibit substrate biases that depend upon

- the instrument used
- the nature of the substrate
- the level of lead in the paint
- possible other factors such as source age, temperature, and humidity.

These same factors affect the magnitude and direction (positive or negative) of the bias. Results can be biased in either the positive or negative direction and may be quite high (up to 3 mg/cm²). Many of the newer XRF analyzers include internal software to minimize or eliminate the effect of substrate bias on the readings displayed by the instrument.

Some XRFs need to be corrected for substrate bias; some do not.

In order to standardize the way each instrument is used and how readings are corrected for substrate effect, HUD and EPA developed *XRF Performance Characteristics Sheets* for each of the commercially available XRF analyzers. Some XRF instruments do not need to have their readings corrected for substrate bias because their internal software compensates for it automatically. This type of substrate bias correction is done by the instrument. Other instruments only require substrate correction procedures on specific substrates or when XRF results are below a certain value. In the current edition of all XRF PCSs, all instruments requiring substrate correction include a level of 4.0 mg/cm², at or above which the correction procedure is not necessary. At that level, the worst-case substrate effect would not be so great that correcting for it would bring an otherwise positive classification for lead below the

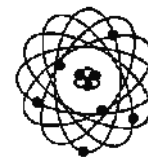

Theory and Use of X-Ray Fluorescence (XRF) Analyzers

regulatory level. The PCS should be consulted to determine the requirements for each specific instrument. The PCS will state which, if any, substrates require correction and which do not.

Substrate Correction Protocol

XRF results are corrected for substrate bias by subtracting a number, which is determined separately for each type of substrate that requires a correction. The correction value (formerly called "Substrate Equivalent Lead" or "SEL") is an average of XRF readings taken from test locations that have been scraped clean of their paint covering. A criterion for selecting these test locations is that their initial XRF results are less than 2.5 mg/cm^2 . This level was chosen to reduce the impact of lead which may have "bled" into a porous substrate (i.e., wood or brick) and to prevent testing a spot where a nail or metal pipe causes a high substrate reading. If test locations with XRF results equal to or greater than 2.5 mg/cm^2 were selected, the outcome might "overcorrect" XRF results. Therefore, only test locations with initial XRF results less than 2.5 mg/cm^2 should be chosen. If all initial readings on a substrate type are above 2.5 mg/cm^2 , the locations with the lowest initial reading should be chosen.

It is important to remember that some XRF results may not need to be corrected for substrate bias depending upon

- the specific instruments used
- the substrate
- the initial reading levels, and
- the specifications in the *XRF Performance Characteristics Sheet*.

Methods for performing substrate corrections are discussed in detail in Chapter 7.

If substrate correction is needed, use test locations with XRF results of less than 2.5 mg/cm^2 .

The need for substrate correction depends on:

- the specific instruments used
- the substrate;
- initial reading levels;
- the PCS.



Field quality control procedures help evaluate whether an instrument is working properly.

Field Quality Control Procedures

Field quality control procedures are needed in XRF testing to protect against two kinds of instrumental problems. The first is drift of the instrument's calibration, in which there is a systematic change over time in the average reading of the instrument. Drift is caused by instability of the instrument's electronics or by aging of the battery, resulting in failure of the battery to charge properly. *Drift cannot be corrected in the field; the instrument must be returned for factory service.* The second problem is unusually high variability in the measurements. XRF analyzers, like all scientific instruments, are subject to some degree of natural measurement variability from a variety of sources. The variability to be expected in each instrument has been quantified by NIST and HUD. Unusually high variability can substantially degrade the quality of the measurements.

Accuracy, Precision, and Bias

In order to accurately measure the level of lead in paint, the XRF instrument must be working properly. Before describing the procedures an inspector must complete to verify that the XRF is working, a discussion of three important measurement terms is warranted.

- *Accuracy* is defined as the agreement of a reading or measurement or average of measurements with the true value.
- *Precision* is the degree of agreement of repeated measurements (using the same instrument and methods) sometimes expressed as the range or dispersion of measured points (e.g., standard deviation).
- *Bias* is the systematic difference between precise measurements and accurate measurements (i.e., the "true value"). A systematic difference means that the measurements are inaccurate in a particular direction, such as too high or too low (see Figure 5-7d).

For XRF instruments, the precision may be influenced by the length of measurement, random source decay variation, and substrate/matrix effects (discussed earlier in this chapter). Figure 5-7 illustrates the difference between bias and precision using several "bulls-eye targets."

In Figure 5-7a, if a "bulls-eye" is the optimal outcome, this "instrument" is neither accurate (no hits within the inner bulls-eye) nor precise (no consistency of the repeated shots; they are all over the target).

Figure 5-7b represents both very good accuracy (no bias) and precision (all the shots are very close together and on target).

Figure 5-7c represents fairly good accuracy, but not very good precision (shots *on average* have hit the bulls-eye, but the shots are still not clustered very close together).

The bias and precision of the XRF affect the readings.



Figure 5-7. Examples of accuracy, precision, and bias

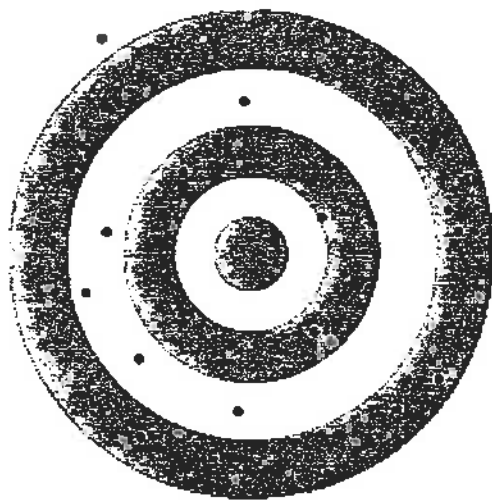

5-7a

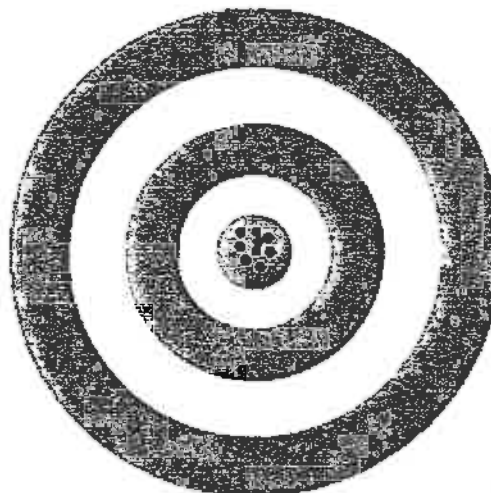

5-7b

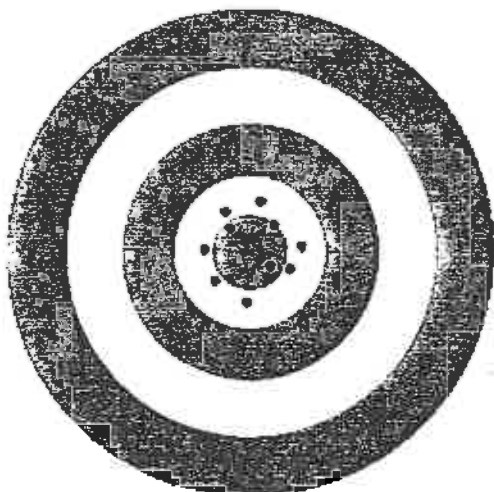

5-7c



5-7d

Figure 5-7d represents very good precision (all the shots are clustered together), but poor accuracy (shots are nowhere near the bulls-eye) and therefore significant bias.

For XRF instruments, bias is generally due to calibration errors, systematic hardware problems related to the electronics of the instrument, or systematic software problems related to internal compensation for the substrate/matrix effects. In order to determine how accurate a particular XRF is on any given day, the inspector must conduct calibration checks.

Bias is the systematic difference between precise measurements and accurate measurements.



Calibration checks ensure the instrument is reading the level of lead accurately.

Never use an XRF analyzer that cannot pass the calibration test!

A SRM closest to 1.0 mg/cm² is used to check the instrument's calibration.

Inspecting for Lead-based Paint

Calibration Checks

In addition to the manufacturer's recommended warm-up and quality control procedures, the XRF operator should take the quality control readings recommended in this section, unless these are less stringent than the manufacturer's instructions.

A calibration check¹ is simply a series of measurements on a film or coupon with a known amount of lead-based paint applied to it (i.e., a standard reference material [SRM]) to verify that the instrument is working properly. These measurements are averaged and then the value is compared to the calibration check limits of that particular XRF analyzer to determine if the instrument is within those limits. *(Note: The inspector cannot recalibrate the XRF analyzers; recalibration must be done by the manufacturer. This procedure is only to verify that the instrument is in proper calibration in accordance with the PCS.)* **Do not use an XRF analyzer if the calibration check results are outside the PCS tolerance limits!**

A check of the instrument's calibration is the first step in ensuring proper operation of the instrument and in determining that the data generated during the inspection are accurate. Each instrument's PCS includes a protocol for conducting a calibration check. This check must be done, at a minimum,

- at the beginning of each inspection;
- at least every 4 hours during the inspection, or more frequently if the manufacturer recommends it; and
- at the end of each inspection.

The inspector will need the following items in order to conduct a calibration check:

- the X-ray fluorescence analyzer which will be used to conduct the inspection;
- the PCS for the X-ray fluorescence analyzer;
- a calibration check test results form (a sample form is included as Appendix A);
- a Standard Reference Material (SRM) closest to 1.0 mg/cm² (usually the NIST 1.02 SRM film is used);
- a piece of solid wood (not plywood), Styrofoam, or other nonmetal rigid substrate unless the SRM will be attached directly to the XRF probe.

¹This procedure assumes that the federal lead-based paint standard of 1.0 mg/cm² is being used. If a different standard is being used, other NIST SRMs should be used to determine instrument performance against the different standard. At this time, however, no method for determining performance characteristics using different standards has been developed.



Theory and Use of X-Ray Fluorescence (XRF) Analyzers

Before beginning testing within the dwelling the inspector must:

- attach the SRM to the piece of nonmetal substrate material (or attach it directly to the XRF probe),

(The NIST SRM film should *not* be placed on a tool box, suitcase, or surface coated with paint, shellac, or any other coating to take calibration check readings. The SRM should be positioned so that readings are taken when it is more than one foot (0.3 meters) away from a potential source of error. For example, the NIST SRM can be placed on top of a one-foot- (0.3-meter) thick piece of Styrofoam or other lead-free material, as recommended by the manufacturer, before taking readings.)

- take three XRF measurements (as directed by the instrument's PCS) on the SRM;
- record each of the readings on the calibration check test results form,
- average the three readings, rounded to the same number of decimal places as the XRF instrument displays, and
- compare the result with the calibration check limits on the PCS for the XRF analyzer.

In most cases, the average will fall within the calibration check limits listed on the PCS for that instrument. However, should the average of the three readings fall outside of the limits for the instrument, the manufacturer's instructions should be followed to bring the instrument back into control. A second calibration check should then be conducted to determine if the instrument is within tolerance limits before being used.

If the recommended actions do not result in the readings falling within the calibration tolerance limits, the XRF operator should contact the manufacturer for additional instructions. The instrument may require service at the manufacturer's repair facility. Until a valid calibration check has been completed, that instrument must not be used for testing!

Once testing has begun, a second calibration check must be conducted *at least* every four hours or at the end of testing, whichever occurs first. Some inspectors choose to check their instrument's calibration more frequently to avoid losing several hours of data should the intermediate or final calibration check result in readings outside of the tolerance limits for that instrument. Readings not accompanied by successful calibration checks at the beginning and end of the testing period are unreliable and should be repeated after a successful calibration check has been made. If a backup XRF instrument is used as a replacement, it must successfully pass the initial calibration check test before retesting the affected test locations.

Take 3 readings on the SRM and average the result.

Calibration checks must be conducted at the beginning, every 4 hours, and at the end of an inspection.



Standard Reference Materials

NIST has developed a set of Standard Reference Paint Films (SRM 2579a) for use in lead-based paint testing. There are 5 films. The colors, lead levels, and associated confidence intervals are as follows²:

Yellow	$3.53 \text{ mg/cm}^2 \pm 0.24 \text{ mg/cm}^2$
Orange	$1.63 \text{ mg/cm}^2 \pm 0.08 \text{ mg/cm}^2$
Red	$1.02 \text{ mg/cm}^2 \pm 0.04 \text{ mg/cm}^2$
Green	$0.29 \text{ mg/cm}^2 \pm 0.01 \text{ mg/cm}^2$
White	$<0.0001 \text{ mg/cm}^2$

In order to standardize the substrate correction and field quality control for XRF testing, all inspectors must use the NIST Standard Reference Paint Films. They can be purchased from NIST by calling 301-975-6776. Additional information on Standard Reference Materials for lead in paint, soil, and dust can be obtained on NIST's web site (<http://www.nist.gov>) or by electronic mail (srminfo@nist.gov).

² The colors, lead levels, and confidence intervals may change in future issues of the NIST standard reference paint films.



Theory and Use of X-Ray Fluorescence (XRF) Analyzers

Licensing and Registration of XRF Analyzers

The responsibility for registering an XRF analyzer and obtaining the appropriate licenses rests with the owner of the company performing the inspection. However, even if an inspector is not a proprietor, he/she may be asked to arrange for licenses and permits. The main government agencies that regulate radioactive materials are the Nuclear Regulatory Commission (NRC), an agency of the federal government, and various state authorities. The NRC has responsibility to regulate uranium and its by-products, which are reactor-produced materials. Most cobalt-57 and cadmium-109 sources used in lead-in-paint XRF analyzers are produced in atomic accelerators, not in nuclear reactors and are therefore not included among those substances which are subject to NRC regulation. (Note: Cadmium-109 is made either way, by reactor or by accelerator. The regulations that apply may depend on how your particular source was produced.) However, most state authorities have regulations regarding the XRF analyzer and its source. Twenty-six states have entered into agreements with the NRC to assume responsibility for the regulation of uranium and its by-products. These states are called *agreement states*. Agreement states tend to have regulations that are more stringent than those of either the NRC or the non-agreement States.

Every state has one of three different ways to regulate the radioactive source in an XRF. For ease of explanation we are separating them into three categories:

- registration or certification states
- licensing states
 - agreement states
 - nonagreement states.

A primary difference between licensing and registration is that licensing requires that individual, *qualified* persons are listed on the license (the license is issued to the owning entity). That qualification must be established by providing the licensing agency, as part of the application, with proof (in the form of an attendance certificate, for example) that the person to be listed on the license has received sufficient radiation safety training (preferably from the XRF manufacturer at a user school) to be able to operate and care for the XRF with adequate safety. Registration doesn't usually have that requirement.

In very general terms, a certification state requires the least amount of effort to obtain a "permit" to have and operate an XRF analyzer in the state. Generally, the paperwork consists of a short form requiring the following information at a minimum: brand of XRF (sometimes referred to as type of "gauge"); type and size of the radioactive source; and name of the radiation safety officer (RSO) is for the company. There is usually a fee involved, but it is often less than \$100.

Accelerator-produced radioactive materials are not regulated by the NRC, but are regulated by the state.

In licensing states, and some registration states, you cannot take possession of an XRF without a license.



Specific Licenses

Licensing states ordinarily require a significant amount of paperwork and can take up to six months to complete the process. However, on average, the time from start to finish is about four weeks. It is important to plan ahead to make sure the paperwork is processed and the inspector has a license to possess that specific radioactive source(s) before taking delivery of an XRF. *An inspector cannot legally take possession of an XRF in a licensing state (or registration, in some registration states) without this license.* The manufacturer of the XRF should require you to provide them with a copy of your license or registration (if applicable) before they ship the XRF to you. If the company has an existing license it may have to be amended to either add additional radioactive sources or use a different size or type of radioactive source. Amendments can take as long as getting an original license so don't put off doing this until the last minute.

Most licensing states will require an on-site visit by one of their inspectors to verify that the inspector is in compliance with the regulations. They will confirm that the inspector and the company are following the procedures that were outlined in the licensing application operating procedures. This will include:

- safe storage of the XRF,
- safe transportation of the XRF,
- safe use of the XRF, and
- safe emergencies for the XRF.

What is a safe emergency? It is an emergency that you plan for! Losing or dropping your XRF are examples of such emergencies. Depending on the type of emergency, the steps you take and the order in which you take them may differ. Here are two examples of emergency an inspector might encounter.

Example number one:

An XRF analyzer is stolen from a job site:

- notify the police and state/tribal agency regulating radioactive material;
- notify the company's RSO
- follow any additional procedures documented in your standard procedures manual.

It is recommended that the inspector carry a set of emergency numbers in the XRF case. However, since the XRF (and probably case) have been stolen, this example highlights the importance of

You must have procedures established should an emergency occur.



Theory and Use of X-Ray Fluorescence (XRF) Analyzers

having a set of emergency numbers and contacts *on your person* at all times when travelling with or using an XRF analyzer.

Example number two:

An XRF is dropped and the integrity of the radioactive source may be compromised.

This is treated just like a hazardous spill.

- stay with the instrument;
- cordon off a safe distance (10 feet) around the instrument;
- send someone to contact:
 - the local emergency response team (no one should touch the instrument until the emergency response team arrives)
 - your company's RSO
- contact the manufacturer once the instrument is contained.

If, during the on-site audit by the state, any deficiencies are found, you will be notified in writing. You must correct these deficiencies within a specific period of time and provide written documentation of how you addressed and remedied each deficiency.

Licensing fees and renewal fees vary significantly by state. Some states require annual fees, while others require the fee every two or three years. The fees can range from \$300 per year up to \$2,200 for three years.

Reciprocity

Reciprocity is the ability to bring an XRF from one state into another without having to get another license. Some licensing states are also agreement states. An agreement state agrees to honor another state's license to possess radioactive materials. There are sometimes conditions to reciprocity. Sometimes a fee is required for reciprocity. This fee can be as high as the fee charged to get a license in that state. There may be additional paperwork. This can be as simple as a letter stating your intent to bring the XRF into the state and where it will be used; or it may be a form several pages in length. In both cases you will have to submit a copy of your current license to them with the additional paperwork. You will also be required to provide a copy of the most recent leak test results (which must be less than 6 months old) on that XRF analyzer.

Reciprocity also requires that the additional paperwork must be carried with the XRF. This always means a copy of the state radiation regulations of the state to which the inspector is travelling should be kept with the XRF. In addition, *an inspector should always have a copy of the XRF license and a log book, no matter where the inspector is.*

Reciprocity is the ability to bring an XRF from one state into another without getting another license.

You should always have a copy of your license and logbook with you.



Inspecting for Lead-based Paint

Some states *require* the use of dosimeters to monitor your exposure to radiation. If you go from one state to another under reciprocity and the state you're visiting requires dosimetry, you must comply. This is true even if your licensing state does not require dosimetry. Documentation of your dosimetry results must be included in the paperwork carried along with the XRF analyzer.

What happens if you get inspected when you're in another state and they find deficiencies? The same thing that happens when you get cited in your own state. Failure to correct these deficiencies, or if they find gross violations, may prevent you from getting reciprocity in that state again. You could also be asked to leave the state.

Another reciprocity issue involves licensing. Often, an inspector will be working most of the time in one state but may occasionally work in other states. If that is the case, the inspector must comply with the regulations about transporting and operating the equipment in the other state(s). Almost every state requires that the appropriate authority be notified that the device will be transported into the state. If an inspector is licensed in an agreement state, there is likely to be reciprocity with any other state. However, if the inspector's license is not from an agreement state, it is likely that there is no reciprocity agreement. Therefore, all inspectors must understand the reciprocity agreements relevant to the specific set of states in which they will be operating.

One last word about reciprocity. It is presumed that you are going to visit that state under reciprocity, not stay there. There is usually a time limit for eligibility under reciprocity—six months for most states, but much less in other states. If the XRF is to be used more than this time period, you must get a license in that state. The time period is the total time in that state during any calendar period. If you bring the XRF back out and then back in the clock is not reset. Every time the XRF is brought back under the rules of reciprocity, a request must again be made and granted. However, the reciprocity fees that have been paid are good for the entire calendar year.

General licenses allow you to take possession of an XRF under the manufacturer's specific license.

General Licenses

Up to this point we have talked about *specific licenses*. In addition to specific licenses, there are *general licenses*. A general license allows the user, such as a lead inspection company, to take possession of the radioactive source under the manufacturer's specific license, thereby eliminating the requirement for the inspector's company to obtain a license. Refer to the attached list for your individual state.

The principal advantages to a general license include usually less paperwork involved and much smaller or no fees to the state. However, there are also disadvantages:

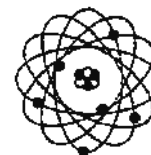

Theory and Use of X-Ray Fluorescence (XRF) Analyzers

- the inspector does not have the ability to use reciprocity, because *the inspector* does not have a specific license;
- many states do not accept general licenses.

The only way to be allowed to use the XRF in another state would be if that state also allowed general licenses. Then, and only then, could the manufacturer send the XRF to an inspector in that state. If the inspector has only a general license and no specific license for the state into which he/she wants to travel, *he/she* cannot bring the XRF in from one general license state to another general license state.

In other words, let's say you normally work in state A under the manufacturer's general license. You get a request for an inspection in state B, in which *you* do not hold a specific license. In order for you to use the XRF in state B, you must first send the instrument back to the manufacturer (who holds the general license). You then drive from state A into state B and the manufacturer sends the XRF back to you in state B! This example illustrates the importance of checking with each state's agency responsible for radioactive devices *before* travelling across state lines.

XRF Training

Factory training on the particular XRF analyzer being used on a job is required by several federal agencies (e.g., HUD and some branches of the Department of Defense) for each individual using the XRF. It is not acceptable practice by these agencies to allow someone who is factory trained to train other users of the XRF. Direct factory training for each inspector may be a condition in the inspection contract and a violation could result in the contractor retesting all surfaces using factory-trained individuals. Most state radiation regulations also require factory training in radiation safety. State regulators may accept generic radiation training (i.e., training from any of the XRF analyzer manufacturers in lieu of training from the manufacturer of the instrument you are using). The training provided in this course *is not* a substitute for the specific training from the manufacturer. Each user needs to be trained in how to use the instrument(s) he/she will use during lead-based paint inspections. The manufacturer's training course may not provide adequate radiation safety training for any other XRF analyzer. Each XRF analyzer has its own radiation safety requirements, functions, and devices.

If an inspection is conducted in an agreement state, the regulations for accelerator-produced radioactive sources, such as ^{109}Cd or ^{57}Co , are required to follow regulatory programs that are compatible with those of the NRC. (If the ^{109}Cd source was reactor-produced, the applicable regulations will be discussed in the manufacturer's training.) The main components of the regulatory program involve:

This course does not provide you complete XRF training—you must be trained by the manufacturer on their XRF as well.



The USDOT regulates the transportation of radioactive materials.

- safe handling;
- inventory and security of the instrument;
- proper disposal of a depleted radiation source.

Usually, the employer is responsible for maintaining a radiation safety program that trains inspectors and informs them of the specific regulations in the state or states in which they are working. If such a program does not exist, an inspector should inform his/her employer of this situation prior to operating the analyzer.

Transportation

Transporting an XRF analyzer requires specific packaging and, depending upon the type of shielding used in packaging, may require special carriers. The inspector is responsible for following all regulations relating to transporting the device, including obtaining the proper packaging and labeling materials and informing appropriate state agencies.

As discussed in the Health Effects section of this chapter, time, distance, and shielding are all factors in reducing the existence and severity of a potential exposure to radiation. Therefore, the transportation regulations are consistent with those factors, as well as other principles of safe use concerning such equipment. Some of the older model XRF analyzers with larger ^{57}Co sources (i.e., 40 millicuries) cannot be shipped in a commercial passenger plane; however, it may be possible to do so if the device is properly shielded and packaged. Additionally, XRF analyzers **cannot** be shipped by the US Postal Service; however, other package carriers will accept them for shipment if properly packaged and labeled.

The US Department of Transportation (USDOT) has regulations governing the transportation of radioactive materials. These include requirements for labeling and packaging. USDOT has an "exclusive use" category that would apply to most portable XRF lead analyzers. **Exclusive use** means that a single company or individual is responsible for transportation of the device and has control during the transportation. It also requires that the primary use of the conveyance (vehicle) is for the transportation of the device containing the radioactive material. The loading or unloading must be performed by personnel having sufficient radiological training to ensure that the device is being transported safely (the XRF analyzer manufacturer's training should suffice). This is usually applied to mean that the XRF may be

³ The regulations specify radiation levels in millirem/hour units. Units of milliroentgens/hour (mR/hour), which can be read directly by a radiation survey meter, are, in practice, close enough to mrem/hr that USDOT considers them to have the same value and to be acceptable for these measurements.



Theory and Use of X-Ray Fluorescence (XRF) Analyzers

transported in a personal, agency, or company car in *just its carrying case*, as long as radiation levels anywhere on the outside surface of the case do not exceed 2.0 mrem/hour (or, in Standard International units, 0.020 millisieverts /hour [mSv/hr]).³ The exclusive-use category does *not* apply to carrying the XRF as hand-carried baggage on a commercial passenger plane, which is not under the exclusive control of the person carrying the XRF analyzer. A set of instructions for how the shipment is to be carried out, including particulars on who to contact in case of an emergency involving the radioactive material, must accompany the shipment.

When the XRF analyzer is being transported in a personal or company car or truck, it should be in a compartment separate from the driver and preferably as far away as possible (e.g., in the trunk). It should be secured so it will not slide around while the vehicle is moving.

When shipping by common carrier, almost all XRFs can likely be shipped under USDOT's "excepted package" provisions. That category refers to shipments which contain a "limited" amount of the radioactive material (all today's XRFs do, unless many XRFs are being shipped in a single package) and measurement with a radiation survey meter detects no more than 0.5 mrem/hour (0.005 mSv/hour) anywhere on the surface of the shipping container (excluding the carrying case, unless it's also the shipping container).³ If the inspector doesn't have a survey meter, it's accepted practice to use the XRF's factory shipping container, under the assumption that the XRF in its shipping container met that condition when the factory originally shipped it to the inspector. It is legal to hand-carry an XRF on a commercial passenger plane in *just its carrying case* if it meets the "excepted package" conditions. But, it's not advised to attempt do so because getting through airport security may be difficult; the security personnel are unlikely to understand "excepted package" conditions.

If shipping under the "excepted package" provisions of the regulations, it is not necessary to advise the carrier that the shipment contains radioactive material. If the carrier asks what's in the shipment, tell the truth. It's only necessary to say it's an analyzer, or a scientific instrument. If the carrier should ask if it contains radioactive material, then you must tell them it does, but it meets the "excepted package" conditions. Further, under excepted package provisions, no special label is required on the shipping container. However, USDOT regulations do require that a specifically worded statement must accompany the shipment. It can be folded in a packing-list envelope or be inside the package; the statement doesn't have to be externally visible:

This package conforms to the conditions and limitations specified in 49CFR173.424 for radioactive materials, excepted package, instruments or articles, UN-2910.

Radiation labels may be required on the storage case or package.

Transporting an XRF requires specific packaging and labeling.



Inspecting for Lead-based Paint

This notice must also include the company or agency name, address, and phone number, or those to whom the XRF is being shipped.

If shipment is made by Federal Express (FedEx), even for domestic shipments, they require that the airbill contain the following statement, which is required on international shipments by the International Air Transport Association (IATA):

Radioactive material, excepted package—instruments

For common-carrier shipment of a number of instruments in a single package, or one whose shipping-container surface radiation level exceeds

<u>Label Color</u>	<u>Surface Radiation</u>	<u>1 Meter Radiation</u>
White—Radiation I	0.5 mrem/hr (0.005 mSv/hr)	0 0
Yellow—Radiation II	10.0 mrem/hr (0.010 mSv/hr)	0.5 mrem/hr (0.005 mSv/hr)
Yellow—Radiation III	200 mrem/hr 0.2 mSv/hr	10 rem/hr (0.10 mSv/hr)

0.5 mrem/hour (0.005 mSv/hr), for example, one with 40 millicuries of ^{60}Co , other package labeling and documentation may be required. For shipments under these conditions, the required notice that must accompany the shipment is:

This package conforms to the conditions and limitations specified in 49 CFR 173.422 for radioactive materials, instruments, or articles, UN-2910.

As with the excepted-package statement, the notice must include either the name, address, and telephone number of your company or agency, or those to whom the XRF is being shipped.

A set of forms that are specific to the shipment of hazardous or dangerous materials must be prepared and kept with the instrument. Each common carrier will have its own set of forms. In order for the form to be properly completed, information about the instrument model number, activity of the source, and other pertinent information will be needed. As suggested in the next section, this information is best recorded in a log or notebook that is kept with the instrument at all times. When driving with an XRF analyzer in the vehicle, a copy of all transportation documentation should ideally be on the seat next to the driver as well as in the XRF analyzer's storage case.

Keep a copy of all forms beside you while driving.



Theory and Use of X-Ray Fluorescence (XRF) Analyzers

XRF Analyzer Record Keeping

Safe and accurate use of an XRF analyzer requires meticulous documentation. Therefore, a log of the use of all XRF instruments should be maintained. First, the log should contain the registration of the instrument and all pertinent information about the source of radiation involved. Second, the log should provide a complete record of the operation and maintenance schedule of the device.

The operation log should indicate all pertinent events in the life of the analyzer. These events include:

- date on which a particular individual checked out or received the instrument to be under his/her responsibility;
- the dates, times, and locations of each use of the analyzer;
- the date, mode, and destinations for transport of the device;
- the dates and extent of all maintenance operations performed (including replacement of the sealed radiation source);
- records of regular survey meter measurements and wipe tests to monitor radiation leakage from the XRF.

Maintain a detailed log of use, destinations, and maintenance.

Keep all records of survey meter readings and wipe tests.

**References**

Radiation and Risk, University of Michigan, School of Public Health, Ann Arbor, Michigan. Web Site: <http://www.sph.umich.edu>

Radiobiology for the Radiologist, Fourth Edition, Eric Hall, J.B. Lippincott Company, 1994.

Applied Science Associates, Trenton, New Jersey, 1994.

Radiation and You, Victoreen, Inc., Cleveland, Ohio, November 1992.

A Simplified Discussion of Basic Principles and Methods in X-ray Fluorescence, C.D. Papanicolopoulos, Georgia Tech Research Institute, October 1992.

OSHA, 29 CFR 1910.96, *Ionizing Radiation*. Web Site: http://www.osha-slc.gov:80/OshStd_data/1910_1096.html

US Department of Transportation, Research and Special Programs Administration, Radioactive Material Regulations Review, 1998. Web Site: www.dot.gov

University of California—Santa Cruz, Radiation Awareness Training, June 1998. Web Site: <http://ehs.ucsc.edu>



Appendix A





Inspecting for Lead-based Paint

Theory and Use of X-Ray Fluorescence (XRF) Analyzers



Calibration Check Test Results

Page ____ of ____

Address/Unit No. _____

Device _____

Date _____ XRF Serial No. _____

Contractor _____

Inspector _____ Inspector Signature _____

NIST SRM Used _____ mg/cm² Calibration Check Tolerance Used* _____ mg/cm²

First Calibration Check

NIST SRM			First Average	Within Limits	Outside of Limits
First Reading	Second Reading	Third Reading			

Second Calibration Check

NIST SRM			First Average	Within Limits	Outside of Limits
First Reading	Second Reading	Third Reading			

Third Calibration Check (if required)

NIST SRM			First Average	Within Limits	Outside of Limits
First Reading	Second Reading	Third Reading			

Fourth Calibration Check (if required)

NIST SRM			First Average	Within Limits	Outside of Limits
First Reading	Second Reading	Third Reading			

*If the average falls outside of the XRF Calibration Check Tolerance Limits listed on the instrument's Performance Characteristics Sheet (PCS), consult the manufacturer's recommendations to bring the instrument back into control. Retest all testing combinations tested since the last successful Calibration Check test.

XRF PERFORMANCE CHARACTERISTICS SHEET
Princeton Gamma-Tech, Inc.; XK-3

EFFECTIVE DATE: September 25, 1995

EDITION NO.: 1

MANUFACTURER AND MODEL:

Make: Princeton Gamma-Tech, Inc.
Model: XK-3
Source: Co⁵⁷
Note: This sheet supersedes all previous sheets for the XRF instrument of the make, model, and source shown above

EVALUATION DATA SOURCE AND DATE:

This sheet is supplemental information to be used in conjunction with Chapter 7 of the HUD *Guidelines for the Evaluation and Control of Lead-Based Paint Hazards in Housing* ("HUD Guidelines"). Performance parameters shown on this sheet are calculated from evaluation data collected during the EPA/HUD field evaluation study conducted from March through October 1993. The data were collected from approximately 1,200 test locations using three instruments. One instrument had a March 1993 source and the other two instruments had April 1993 sources. All three instruments had sources with 10 mCi initial strengths. The results of this study are reported in *A Field Test of Lead-Based Paint Testing Technologies: Technical Report*, EPA 747-R-95-002b, May 1995.

FIELD OPERATION GUIDANCE

OPERATING PARAMETERS:

Performance parameters shown in this sheet are applicable only when operating the instrument under the same conditions as the evaluation testing and using the procedures described in Chapter 7 of the HUD Guidelines. Operating parameters include:

- Manufacturer-recommended warm-up and quality control procedures
- Use the Multifamily Decision Flowchart for determining the presence of lead on a component type in multifamily housing
- Nominal 15-second readings on three locations per component for single-family housing and one location per component for multifamily housing
- Calibration checks are taken using the red (1.02 mg/cm²) NIST Standard Reference Material (SRM No. 2579) paint film
- Readings for determining the substrate correction values are taken on bare substrate covered with red (1.02 mg/cm²) NIST SRM paint film
- Lead-based paint is defined as paint with lead equal to or in excess of 1.0 mg/cm².

XRF PERFORMANCE CHARACTERISTICS SHEET
Princeton Gamma-Tech, Inc.; XK-3

XRF CALIBRATION CHECK:

Chapter 7 of the HUD Guidelines recommends using a calibration check procedure to determine the operating condition of the XRF instrument. For this instrument, calibration check readings should be taken on wood. If the observed calibration check average minus 1.02 mg/cm² is greater than the positive (plus) calibration check tolerance value, or less than the negative (minus) calibration check tolerance value, then the instructions provided by the manufacturer should be followed in order to bring the instrument back into control before any more XRF testing is done. Testing must cease for those instruments with readings that exceed the calibration check tolerance limits in accordance with manufacturer's specifications. This calibration check is estimated to produce an incorrect result (that is, a finding that the instrument is out of calibration) very infrequently - once out of every 200 times this procedure is followed.

minus value = -0.5 mg/cm²
 plus value = +1.3 mg/cm²

(Operators may choose to use the limits in the manufacturer's instruction manual for this calibration check. The rate of an incorrect result if the limits in the manufacturer's instruction manual are followed may be different from the rate of an incorrect result stated here).

FOR XRF RESULTS BELOW 4.0 mg/cm², SUBSTRATE CORRECTION RECOMMENDED FOR: -

Brick, Concrete, Drywall, Metal, Plaster, and Wood.

SUBSTRATE CORRECTION NOT RECOMMENDED FOR:

None.

SUBSTRATE CORRECTION VALUE COMPUTATION:

Chapter 7 of the HUD Guidelines provides guidance on correcting XRF results for substrate bias. Supplemental guidance for using the red (1.02 mg/cm²) NIST SRM paint film for substrate correction is provided below.

XRF results are corrected for substrate bias by subtracting from each XRF result a correction value determined separately in each house for single-family housing or in each development for multifamily housing, for each substrate. The correction value is an average of XRF readings taken over red NIST SRM (1.02 mg/cm²) paint films at test locations that had been scraped clean of their paint covering. Compute the correction values as follows:

Using the same XRF instrument, take three readings on a bare substrate area covered with the red NIST SRM (1.02 mg/cm²) paint film. Repeat this procedure by taking three more readings on a second bare substrate area of the same substrate covered with the red NIST SRM (1.02 mg/cm²) paint film.

XRF PERFORMANCE CHARACTERISTICS SHEET
Princeton Gamma-Tech, Inc.; XK-3

- Compute the correction value for each substrate type by computing the average of all six readings as shown below.

For each substrate type:

$$\text{Correction Value} \left. \vphantom{\text{Correction Value}} \right\} = \frac{1^{\text{st}} + 2^{\text{nd}} + 3^{\text{rd}} + 4^{\text{th}} + 5^{\text{th}} + 6^{\text{th}} \text{ Reading}}{6} - 1.02 \text{ mg/cm}^2$$

- Repeat this procedure for each substrate tested in the house or housing development.

INCONCLUSIVE RANGE OR THRESHOLD:

XRF results are classified using either the threshold or the inconclusive range. In single-family housing, an XRF result is the average of three readings taken on a testing combination. (A testing combination is a location on a painted surface as defined in Chapter 7 of the HUD Guidelines). In multifamily housing, an XRF result is a single reading taken on a testing combination. For computing the XRF result, use all digits that are reported by the instrument. For the threshold, results are classified as positive if they are greater than or equal to the threshold, and negative if they are less than the threshold. There is no inconclusive classification when using the threshold. For the inconclusive range, results are classified as positive if they are greater than or equal to the upper limit of the inconclusive range, and negative if they are less than or equal to the lower limit of the inconclusive range. Thresholds and inconclusive ranges were determined for comparing results to the 1.0 mg/cm² standard. For a listing of laboratories recommended by the EPA National Lead Laboratory Accreditation Program (NLLAP) for the analysis of samples to resolve an inconclusive XRF result or additional confirmational analysis, call the National Lead Information Center Clearinghouse at 1-800-424-LEAD.

DESCRIPTION	SUBSTRATE	THRESHOLD (mg/cm ²)	INCONCLUSIVE RANGE (mg/cm ²)
Readings corrected for substrate bias on all substrates	Brick	None	0.9 to 1.3
	Concrete	None	0.8 to 1.7
	Drywall	1.0	None
	Metal	None	0.4 to 1.8
	Plaster	None	0.7 to 1.4
	Wood	None	0.9 to 1.4

INSTRUCTIONS FOR EVALUATING XRF TESTING:

Chapter 7 of the HUD Guidelines recommends several options for evaluating XRF testing. Among those options is the following procedure which may be used after XRF testing has been completed. In single-family housing, an XRF result is the average of three readings taken on a testing combination. (A testing combination is a location on a painted surface as defined in Chapter 7 of the HUD Guidelines). In multifamily housing, an XRF result is a single reading taken on a testing combination. If a multifamily housing development is being retested, randomly select two units from within the development from which

XRF PERFORMANCE CHARACTERISTICS SHEET
Princeton Gamma-Tech, Inc.; XK-3

the ten testing combinations should be randomly selected.

Randomly select ten testing combinations for retesting from each house or from the two selected units.

Conduct XRF retesting at the ten testing combinations selected for retesting.

Determine if the XRF testing in the units or house passed or failed the test by applying the steps below.

Compute the Retest Tolerance Limit by the following steps:

Determine XRF results for the original and repeat XRF readings. Do not correct the original or retest results for substrate bias. In single-family housing a result is defined as the average of three readings. In multifamily housing, a result is a single reading. Therefore, there will be ten original and ten repeat XRF results for each house or for the two selected units.

Compute the square of each of the ten original and ten repeat XRF results.

Add these squares of XRF results together. Call this quantity C.

Multiply the number C by 0.0072. Call this quantity D.

Add the number 0.032 to D. Call this quantity E.

Take the square root of E. Call this quantity F.

Multiply F by 1.645. The result is the Retest Tolerance Limit.

Compute the overall average of all ten original XRF results over all ten testing combinations selected for retesting.

Compute the overall average of all ten repeat XRF results over all ten testing combinations selected for retesting.

Take the difference of the overall average of the ten original XRF results and the overall average of the ten repeat XRF results. If the difference is negative, drop the negative sign.

If the difference of the overall averages is less than the Retest Tolerance Limit, the inspection has passed the retest. If the difference of the overall averages equals or exceeds the Retest Tolerance Limit, this procedure should be repeated with ten new testing combinations. If the difference of the overall averages is equal to or greater than the Retest Tolerance Limit a second time, then the inspection should be considered deficient.

Use of this procedure is estimated to produce a spurious result approximately 1% of the time. That is, results of this procedure will call for further examination when no examination is warranted in approximately 1 out of 100 dwelling units tested.

XRF PERFORMANCE CHARACTERISTICS SHEET
Princeton Gamma-Tech, Inc.; XK-3

EFFECTIVE DATE: September 25, 1995

EDITION NO.: 1

MANUFACTURER AND MODEL:

Make: Princeton Gamma-Tech, Inc.
Model: XK-3
Source: Co⁵⁷
Note: This sheet supersedes all previous sheets for the XRF instrument of the make, model, and source shown above

EVALUATION DATA SOURCE AND DATE:

This sheet is supplemental information to be used in conjunction with Chapter 7 of the HUD *Guidelines for the Evaluation and Control of Lead-Based Paint Hazards in Housing* ("HUD Guidelines"). Performance parameters shown on this sheet are calculated from evaluation data collected during the EPA/HUD field evaluation study conducted from March through October 1993. The data were collected from approximately 1,200 test locations using three instruments. One instrument had a March 1993 source and the other two instruments had April 1993 sources. All three instruments had sources with 10 mCi initial strengths. The results of this study are reported in *A Field Test of Lead-Based Paint Testing Technologies: Technical Report*, EPA 747-R-95-002b, May 1995.

FIELD OPERATION GUIDANCE

OPERATING PARAMETERS:

Performance parameters shown in this sheet are applicable only when operating the instrument under the same conditions as the evaluation testing and using the procedures described in Chapter 7 of the HUD Guidelines. Operating parameters include:

- Manufacturer-recommended warm-up and quality control procedures
- Use the Multifamily Decision Flowchart for determining the presence of lead on a component type in multifamily housing
- Nominal 15-second readings on three locations per component for single-family housing and one location per component for multifamily housing
- Calibration checks are taken using the red (1.02 mg/cm²) NIST Standard Reference Material (SRM No. 2579) paint film
- Readings for determining the substrate correction values are taken on bare substrate covered with red (1.02 mg/cm²) NIST SRM paint film
- Lead-based paint is defined as paint with lead equal to or in excess of 1.0 mg/cm².

XRF PERFORMANCE CHARACTERISTICS SHEET
Princeton Gamma-Tech, Inc.; XK-3

XRF CALIBRATION CHECK:

Chapter 7 of the HUD Guidelines recommends using a calibration check procedure to determine the operating condition of the XRF instrument. For this instrument, calibration check readings should be taken on wood. If the observed calibration check average minus 1.02 mg/cm² is greater than the positive (plus) calibration check tolerance value, or less than the negative (minus) calibration check tolerance value, then the instructions provided by the manufacturer should be followed in order to bring the instrument back into control before any more XRF testing is done. Testing must cease for those instruments with readings that exceed the calibration check tolerance limits in accordance with manufacturer's specifications. This calibration check is estimated to produce an incorrect result (that is, a finding that the instrument is out of calibration) very infrequently - once out of every 200 times this procedure is followed.

minus value = -0.5 mg/cm²
 plus value = +1.3 mg/cm²

(Operators may choose to use the limits in the manufacturer's instruction manual for this calibration check. The rate of an incorrect result if the limits in the manufacturer's instruction manual are followed may be different from the rate of an incorrect result stated here).

FOR XRF RESULTS BELOW 4.0 mg/cm², SUBSTRATE CORRECTION RECOMMENDED FOR:

Brick, Concrete, Drywall, Metal, Plaster, and Wood.

SUBSTRATE CORRECTION NOT RECOMMENDED FOR:

None.

SUBSTRATE CORRECTION VALUE COMPUTATION:

Chapter 7 of the HUD Guidelines provides guidance on correcting XRF results for substrate bias. Supplemental guidance for using the red (1.02 mg/cm²) NIST SRM paint film for substrate correction is provided below.

XRF results are corrected for substrate bias by subtracting from each XRF result a correction value determined separately in each house for single-family housing or in each development for multifamily housing, for each substrate. The correction value is an average of XRF readings taken over red NIST SRM (1.02 mg/cm²) paint films at test locations that had been scraped clean of their paint covering. Compute the correction values as follows:

- Using the same XRF instrument, take three readings on a bare substrate area covered with the red NIST SRM (1.02 mg/cm²) paint film. Repeat this procedure by taking three more readings on a second bare substrate area of the same substrate covered with the red NIST SRM (1.02 mg/cm²) paint film.

XRF PERFORMANCE CHARACTERISTICS SHEET
Princeton Gamma-Tech, Inc.; XK-3

- Compute the correction value for each substrate type by computing the average of all six readings as shown below.

For each substrate type:

$$\text{Correction Value} = \frac{1^{\text{st}} + 2^{\text{nd}} + 3^{\text{rd}} + 4^{\text{th}} + 5^{\text{th}} + 6^{\text{th}} \text{ Reading}}{6} - 1.02 \text{ mg/cm}^2$$

- Repeat this procedure for each substrate tested in the house or housing development.

INCONCLUSIVE RANGE OR THRESHOLD:

XRF results are classified using either the threshold or the inconclusive range. In single-family housing, an XRF result is the average of three readings taken on a testing combination. (A testing combination is a location on a painted surface as defined in Chapter 7 of the HUD Guidelines). In multifamily housing, an XRF result is a single reading taken on a testing combination. For computing the XRF result, use all digits that are reported by the instrument. For the threshold, results are classified as positive if they are greater than or equal to the threshold, and negative if they are less than the threshold. There is no inconclusive classification when using the threshold. For the inconclusive range, results are classified as positive if they are greater than or equal to the upper limit of the inconclusive range, and negative if they are less than or equal to the lower limit of the inconclusive range. Thresholds and inconclusive ranges were determined for comparing results to the 1.0 mg/cm² standard. For a listing of laboratories recommended by the EPA National Lead Laboratory Accreditation Program (NLLAP) for the analysis of samples to resolve an inconclusive XRF result or additional confirmational analysis, call the National Lead Information Center Clearinghouse at 1-800-424-LEAD.

DESCRIPTION	SUBSTRATE	THRESHOLD (mg/cm ²)	INCONCLUSIVE RANGE (mg/cm ²)
Readings corrected for substrate bias on all substrates	Brick	None	0.9 to 1.3
	Concrete	None	0.8 to 1.7
	Drywall	1.0	None
	Metal	None	0.4 to 1.8
	Plaster	None	0.7 to 1.4
	Wood	None	0.9 to 1.4

INSTRUCTIONS FOR EVALUATING XRF TESTING:

Chapter 7 of the HUD Guidelines recommends several options for evaluating XRF testing. Among those options is the following procedure which may be used after XRF testing has been completed. In single-family housing, an XRF result is the average of three readings taken on a testing combination. (A testing combination is a location on a painted surface as defined in Chapter 7 of the HUD Guidelines). In multifamily housing, an XRF result is a single reading taken on a testing combination. If a multifamily housing development is being retested, randomly select two units from within the development from which

XRF PERFORMANCE CHARACTERISTICS SHEET
Princeton Gamma-Tech, Inc.; XK-3

the ten testing combinations should be randomly selected.

Randomly select ten testing combinations for retesting from each house or from the two selected units.

Conduct XRF retesting at the ten testing combinations selected for retesting.

Determine if the XRF testing in the units or house passed or failed the test by applying the steps below.

Compute the Retest Tolerance Limit by the following steps:

Determine XRF results for the original and repeat XRF readings. Do not correct the original or retest results for substrate bias. In single-family housing a result is defined as the average of three readings. In multifamily housing, a result is a single reading. Therefore, there will be ten original and ten repeat XRF results for each house or for the two selected units.

Compute the square of each of the ten original and ten repeat XRF results.

Add these squares of XRF results together. Call this quantity C.

Multiply the number C by 0.0072. Call this quantity D.

Add the number 0.032 to D. Call this quantity E.

Take the square root of E. Call this quantity F.

Multiply F by 1.645. The result is the Retest Tolerance Limit.

Compute the overall average of all ten original XRF results over all ten testing combinations selected for retesting.

Compute the overall average of all ten repeat XRF results over all ten testing combinations selected for retesting.

Take the difference of the overall average of the ten original XRF results and the overall average of the ten repeat XRF results. If the difference is negative, drop the negative sign.

If the difference of the overall averages is less than the Retest Tolerance Limit, the inspection has passed the retest. If the difference of the overall averages equals or exceeds the Retest Tolerance Limit, this procedure should be repeated with ten new testing combinations. If the difference of the overall averages is equal to or greater than the Retest Tolerance Limit a second time, then the inspection should be considered deficient.

Use of this procedure is estimated to produce a spurious result approximately 1% of the time. That is, results of this procedure will call for further examination when no examination is warranted in approximately 1 out of 100 dwelling units tested.

XRF PERFORMANCE CHARACTERISTICS SHEET
Princeton Gamma-Tech, Inc.; XK-3

BIAS AND PRECISION:

Do not use these bias and precision data to correct for substrate bias. These bias and precision data were computed without substrate correction from samples with reported laboratory results less than 4.0 mg/cm² lead. There were 143 testing locations with a laboratory reported result equal to or greater than 4.0 mg/cm² lead. Of these, 1 had an XRF reading less than 1.0 mg/cm². These data are for illustrative purposes only. Actual bias must be determined on the site. Inconclusive ranges provided above already account for bias and precision. Bias and precision ranges are provided whenever significant variability was found between machines of the same model. Units are in mg/cm².

MEASURED AT	SUBSTRATE	BIAS (mg/cm ²)	BIAS RANGES (mg/cm ²)	PRECISION* (mg/cm ²)	PRECISION RANGES (mg/cm ²)
0.0 mg/cm ²	Brick	0.9		0.6	
	Concrete	1.3	(0.6, 1.9)	0.6	(0.2, 0.6)
	Drywall	-0.1	(-0.3, 0.2)	0.3	(0.2, 0.3)
	Metal	0.9	(0.5, 1.4)	0.5	(0.4, 0.5)
	Plaster	0.8	(0.4, 1.7)	0.5	(0.4, 0.5)
	Wood	0.2	(-0.1, 1.0)	0.4	(0.3, 0.5)
0.5 mg/cm ²	Brick	0.9		0.6	
	Concrete	1.3	(0.7, 1.9)	0.6	(0.5, 0.7)
	Drywall	0.0	(-0.2, 0.2)	0.4	(0.3, 0.4)
	Metal	1.1	(0.7, 1.6)	0.8	(0.4, 0.9)
	Plaster	0.8	(0.2, 1.6)	0.8	(0.4, 0.8)
	Wood	0.4	(0.1, 1.1)	0.6	(0.3, 0.9)
1.0 mg/cm ²	Brick	0.9		0.6	
	Concrete	1.3	(0.7, 2.0)	0.7	(0.6, 0.8)
	Drywall	0.0	(-0.1, 0.2)	0.4	(0.4, 0.5)
	Metal	1.3	(0.9, 1.7)	1.0	(0.5, 1.1)
	Plaster	0.8	(0.0, 1.6)	0.6	(0.4, 0.7)
	Wood	0.6	(0.3, 1.3)	0.7	(0.3, 1.2)
2.0 mg/cm ²	Brick	0.9		0.6	
	Concrete	1.3	(0.7, 2.0)	0.8	(0.6, 0.9)
	Drywall	0.1	(0.1, 0.2)	0.6	(0.5, 0.6)
	Metal	1.7	(1.4, 2.1)	1.4	(0.6, 1.6)
	Plaster	0.7	(-0.3, 1.6)	0.7	(0.4, 0.8)
	Wood	1.0	(0.8, 1.5)	0.9	(0.3, 1.7)

*Precision at 1 standard deviation

A document titled *Methodology for XRF Performance Characteristic Sheets* provides an explanation of the statistical methodology used to construct the data in the sheets and provides empirical results from using the recommended inconclusive ranges or thresholds for specific XRF instruments. For a copy of this document call the National Lead Information Center Clearinghouse at 1-800-424-LEAD.

This XRF Performance Characteristic Sheet is a joint product of the U.S. Environmental Protection Agency (EPA) and the U.S. Department of Housing and Urban Development (HUD). The issuance of this sheet does not constitute rulemaking. The information provided here is intended solely as guidance to be used in conjunction with Chapter 7 of the *Guidelines for the Evaluation and Control of Lead-Based Paint Hazards in Housing*. EPA and HUD reserve the right to revise this guidance. Please address questions and comments on this sheet to: Director, Office of Lead-Based Paint Abatement and Poisoning Prevention, U.S. Department of Housing and Urban Development, Room B-133, 451 Seventh St. S.W., Washington, DC 20410.

XRF PERFORMANCE CHARACTERISTICS SHEET
Niton Corporation; XL-309 Spectrum Analyzer

EFFECTIVE DATE: August 24, 1995

EDITION NO.: 1

MANUFACTURER AND MODEL:

Make: Niton Corporation
Model: XL-309 Spectrum Analyzer
Source: Cd¹⁰⁹
Note: This sheet supersedes all previous sheets for the XRF instrument of the make, model, source, and software versions shown above.

EVALUATION DATA SOURCE AND DATE:

This sheet is supplemental information to be used in conjunction with Chapter 7 of the HUD *Guidelines for the Evaluation and Control of Lead-Based Paint Hazards in Housing* ("HUD Guidelines"). Performance parameters shown on this sheet are calculated from the EPA/HUD evaluation using archived building components. Testing was conducted March 1995 on approximately 150 test locations using a single instrument with an October 1994 source at 10 mCi initial strength while running software version 1.2C. These results supersede the 1993 testing of XL prototypes reported in the document titled: *A Field Test of Lead-Based Paint Testing Technologies*.

FIELD OPERATION GUIDANCE

OPERATING PARAMETERS:

Performance parameters shown in this sheet are applicable only when operating the instrument under the same conditions as the evaluation testing and using the procedures described in Chapter 7 of the HUD Guidelines. Operating parameters include:

- Manufacturer-recommended warm-up and quality control procedures
- Use the Multifamily Decision Flowchart for determining the presence of lead on a component type in multifamily housing
- Nominal 20-second readings for L-shell results or 120-second readings for K-shell results on three locations per component for single-family housing and one location per component for multifamily housing
- Calibration checks are taken using the red (1.02 mg/cm²) NIST Standard Reference Material (SRM No. 2579) paint film
- Lead-based paint is defined as paint with lead equal to or in excess of 1.0 mg/cm².

XRF PERFORMANCE CHARACTERISTICS SHEET
Niton Corporation; XL-309 Spectrum Analyzer

XRF CALIBRATION CHECK:

Chapter 7 of the HUD Guidelines recommends using a calibration check procedure to determine the operating condition of the XRF instrument. If the observed calibration check average minus 1.02 mg/cm² is greater than the positive (plus) calibration check tolerance value, or less than the negative (minus) calibration check tolerance value, then the instructions provided by the manufacturer should be followed in order to bring the instrument back into control before any more XRF testing is done. This calibration check is estimated to produce an incorrect result (that is, a finding that the instrument is out of calibration) very infrequently - once out of every 200 times this procedure is followed.

minus value = -0.1 mg/cm²
plus value = +0.1 mg/cm²

FOR XRF RESULTS BELOW 4.0 mg/cm², SUBSTRATE CORRECTION RECOMMENDED FOR:

None

SUBSTRATE CORRECTION NOT RECOMMENDED FOR:

Brick, Concrete, Drywall, Metal, Plaster, and Wood

HOW TO CLASSIFY READINGS:

This section describes how to apply the readings and other information displayed by this instrument to determine the presence or absence of lead in paint using the procedures recommended in Chapter 7 of the HUD Guidelines. These guidelines recommend classifying XRF results as positive, negative, or inconclusive compared to the 1.0 mg/cm² standard. But because this instrument displays readings and ancillary information useful for classification purposes, an algorithmic procedure is described that makes use of not only the XRF reading but some of the other displayed information as well.

As detailed below, the algorithm for classifying results is first applied to 20-second nominal L-shell readings followed by 120-second nominal K-shell readings to resolve inconclusive results and laboratory analysis of paint-chip samples, if necessary. For a listing of laboratories recommended by the EPA National Lead Laboratory Accreditation Program (NLLAP) for the analysis of samples to perform additional confirmational analysis, call the National Lead Information Center Clearinghouse at 1-800-424-LEAD.

XRF results are classified using threshold values. For the XL-309, threshold values are the only values provided for classifying results. Results are classified as positive if they are greater than or equal to the threshold, and as negative if they are less than the threshold. There is no inconclusive classification when using threshold values. However, inconclusive results still may be obtained regardless of whether decisions are based on L-shell readings, K-shell readings, or both, as described below. Use all digits that are reported by the instrument. Threshold values, which were determined for comparing results to the 1.0 mg/cm² standard, are provided in the following table.

XRF PERFORMANCE CHARACTERISTICS SHEET
Niton Corporation; XL-309 Spectrum Analyzer

DESCRIPTION	SUBSTRATE	THRESHOLD* (mg/cm ²)
Results not corrected for substrate bias	Brick	1.0
	Concrete	1.0
	Drywall	1.0
	Metal	1.0
	Plaster	1.0
	Wood	1.0
*Application of the decision making methodology recommended in this PCS can result in inconclusive results regardless of whether decisions are based on L-shell readings, K-shell readings, or both.		

This instrument displays its lead-based paint measurements as both L-shell and K-shell readings based on the corresponding L-shell and K-shell X-ray fluorescence (refer to Chapter 7 of the HUD Guidelines for more details). The L-shell readings (or L-readings) are displayed as a numerical result alone, or as a numerical result preceded by either one greater-than symbol (>) or preceded by two greater-than symbols (>>). The two greater-than symbols will only be displayed when the detected lead level is greater than 5.0 mg/cm². Since the maximum lead level reported by this instrument is 5.0 mg/cm², lead levels greater than 5.0 mg/cm² are displayed as ">>5.0". Other examples of how L-readings can be displayed (in mg/cm² units) are "0.6" and ">0.9". The numerical display alone implies that the instrument measured the lead in the paint at the displayed level using L-shell X-ray fluorescence; 0.6 mg/cm² in the example. A number preceded by a single greater-than symbol indicates that the measurable lead is deeply buried in the paint and the detected lead level is greater than the displayed value. In the example, >0.9 indicates that the instrument detected lead deeply buried in paint at a level greater than 0.9 mg/cm². K-shell readings (or K-readings) are displayed in one of two ways: 1) as a single K-reading plus and minus a "precision" value or 2) as an upper K-reading and lower K-reading.

The algorithm used for testing in multifamily housing differs slightly from that used in single-family housing. This is because the recommended number of readings per testing combination varies between the two types of housing. (A testing combination is a location on a painted surface as defined in Chapter 7 of the HUD Guidelines). In multifamily housing, the HUD Guidelines recommend taking a single XRF reading on a testing combination. In single-family housing, three XRF readings are recommended on each testing combination.

MULTIFAMILY HOUSING XRF RESULT CLASSIFICATIONS:

- A. Take a single 20-second nominal reading on each testing combination.
- B. Classify the L-reading based on the type of information displayed.

If two greater-than symbols are displayed then:

- Classify the >>5.0 L-reading as POSITIVE

If one greater-than symbol is displayed then:

- Classify the L-reading as POSITIVE if the numerical result that follows the greater than symbol is equal to or greater than 1.0.

XRF PERFORMANCE CHARACTERISTICS SHEET
 Niton Corporation; XL-309 Spectrum Analyzer

- Classify the L-reading as **INCONCLUSIVE** if the numerical result that follows the greater than symbol is less than 1.0.

If the numerical L-reading is displayed alone (that is, without any preceding greater-than symbols) then:

- Classify the L-reading as **POSITIVE** if the numerical result is equal to or greater than 1.0.
- Classify the L-reading as **NEGATIVE** if the numerical result is less than 1.0.

C. Resolution of results classified as inconclusive.

All results classified as inconclusive above require further investigation. Take a 120-second nominal XRF reading and use the K-shell reading. In multifamily housing, resolve the inconclusive classification with a single K-shell reading or laboratory analysis as described below.

- Classify the result as **POSITIVE** if either the K-reading minus the displayed precision value or the lower K-reading is equal to or greater than 1.0.
- Classify the result as **NEGATIVE** if either the K-reading plus the displayed precision value or the upper K-reading is less than 1.0.
- Classify the result as **INCONCLUSIVE** if neither of the above decision rules using the K-reading provided a classification which can occur when the upper K-reading is equal to or greater than 1.0 or the lower K-reading is less than 1.0.
- To resolve a remaining **INCONCLUSIVE** classification, remove a paint-chip sample and have it analyzed in a laboratory as described in Chapter 7 of the HUD Guidelines.

SINGLE-FAMILY HOUSING XRF RESULT CLASSIFICATIONS:

- D.** Take three 20-second nominal readings on each testing combination.
- E.** Classify each L-reading using the methodology described in item A under Multifamily Housing XRF Result Classifications.
- F.** Classification of the XRF result for a given testing combination is obtained by combining the individual results of the three L-shell readings as follows:
- A **POSITIVE** classification is obtained if at least two of the three individual L-readings are classified as positive.
 - A **NEGATIVE** classification is obtained if at least two of the three individual L-readings are classified as negative.

XRF PERFORMANCE CHARACTERISTICS SHEET
Niton Corporation; XL-309 Spectrum Analyzer

- An **INCONCLUSIVE** classification is obtained if at least two of the three individual L-readings are classified as inconclusive or if one L-reading is classified as positive, another is classified as negative, and the third is classified as inconclusive.

G. Resolution of results classified as inconclusive.

Any results classified as inconclusive require further investigation in the same manner as described above for multifamily housing with one exception. Take three 120-second nominal K-readings instead of a single one. Obtain a classification by combining the individual results of the three K-readings. Resolve the inconclusive classification by classifying the combined K-shell readings or with laboratory analysis as described below.

- A **POSITIVE** classification is obtained if at least two of the three individual K-readings where classified as positive.
- A **NEGATIVE** classification is obtained if at least two of the three individual K-readings where classified as negative.
- An **INCONCLUSIVE** classification is obtained if at least two of the three individual K-readings where classified as inconclusive.
- To resolve a remaining **INCONCLUSIVE** classification, remove a paint-chip sample and have it analyzed in a laboratory as described in Chapter 7 of the HUD Guidelines.

INSTRUCTIONS FOR EVALUATING XRF TESTING:

Chapter 7 of the HUD Guidelines recommends several options for evaluating XRF testing. Among those options is the following procedure which may be used after XRF testing has been completed. In single-family housing, an XRF result is the average of three readings taken on a testing combination. (A testing combination is a location on a painted surface as defined in Chapter 7 of the HUD Guidelines). In multifamily housing, an XRF result is a single reading taken on a testing combination. If a multifamily housing development is being retested, randomly select two units from within the development from which the ten testing combinations should be randomly selected.

Randomly select ten testing combinations for retesting from each house or from the two selected units.

Conduct XRF retesting at the ten testing combinations selected for retesting.

Determine if the XRF testing in the units or house passed or failed the test by applying the steps below.

Use the 20-second L-shell readings, ignoring the ">" and ">>" symbols that precede the displayed readings if they occur.

Compute the Retest Tolerance Limit by the following steps:

XRF PERFORMANCE CHARACTERISTICS SHEET
Niton Corporation; XL-309 Spectrum Analyzer

Determine XRF results for the original and retest XRF readings. Do not correct the original or retest results for substrate bias. In single-family housing a result is defined as the average of three readings. In multifamily housing, a result is a single reading. Therefore, there will be ten original and ten retest XRF results for each house or for the two selected units.

Compute the square of each of the ten original and ten retest XRF results.

Add these squares of XRF results together. Call this quantity C.

Multiply the number C by 0.0072. Call this quantity D.

Add the number 0.032 to D. Call this quantity E.

Take the square root of E. Call this quantity F.

Multiply F by 1.645. The result is the Retest Tolerance Limit.

Compute the overall average of all ten original XRF results over all ten testing combinations selected for retesting.

Compute the overall average of all ten retest XRF results over all ten testing combinations selected for retesting.

Take the difference of the overall average of the ten original XRF results and the overall average of the ten retest XRF results. If the difference is negative, drop the negative sign.

If the difference of the overall averages is less than the Retest Tolerance Limit, the inspection has passed the retest. If the difference of the overall averages equals or exceeds the Retest Tolerance Limit, this procedure should be repeated with ten new testing combinations. If the difference of the overall averages is equal to or greater than the Retest Tolerance Limit a second time, then the inspection should be considered deficient.

Use of this procedure is estimated to produce a spurious result approximately 1% of the time. That is, results of this procedure will call for further examination when no examination is warranted in approximately 1 out of 100 dwelling units tested.

XRF PERFORMANCE CHARACTERISTICS SHEET
Niton Corporation; XL-309 Spectrum Analyzer

BIAS AND PRECISION:

These bias and precision data were computed without substrate correction using the using 20-second L-shell readings from samples with reported laboratory results less than 4.0 mg/cm² lead. Readings reported by the instrument in the ">x" or ">>x" format were not used in the computation. There were 15 test locations with a laboratory reported result equal to or greater than 4.0 mg/cm² lead. Of these, 12 readings were reported in the ">x" or ">>x" format, but of the 3 remaining, 1 had an XRF reading less than 1.0 mg/cm². These data are for illustrative purposes only. Substrate correction is not recommended for this XRF instrument. Units are in mg/cm².

MEASURED AT	SUBSTRATE	BIAS (mg/cm ²)	PRECISION* (mg/cm ²)
0.0 mg/cm ²	All	0.0	<0.1
0.5 mg/cm ²	All	0.0	0.2
1.0 mg/cm ²	All	0.0	0.3
2.0 mg/cm ²	All	-0.1	0.5

*Precision at 1 standard deviation

A document titled *Methodology for XRF Performance Characteristic Sheets* provides an explanation of the statistical methodology used to construct the data in the sheets and provides empirical results from using the recommended inconclusive ranges or thresholds for specific XRF instruments. For a copy of this document call the National Lead Information Center Clearinghouse at 1-800-424-LEAD.

This XRF Performance Characteristics Sheet is a joint product of the U.S. Environmental Protection Agency (EPA) and the U.S. Department of Housing and Urban Development (HUD). The issuance of this sheet does not constitute rulemaking. The information provided here is intended solely as guidance to be used in conjunction with Chapter 7 of the *Guidelines for the Evaluation and Control of Lead-Based Paint Hazards in Housing*. EPA and HUD reserve the right to revise this guidance. Please address questions and comments on this sheet to: Director, Office of Lead-Based Paint Abatement and Poisoning Prevention, U.S. Department of Housing and Urban Development, Room B-133, 451 Seventh St, S.W., Washington, DC 20410.

XRF PERFORMANCE CHARACTERISTICS SHEET
Scitec Corporation; MAP 4

EFFECTIVE DATE: June 26, 1996

EDITION NO.: 1

MANUFACTURER AND MODEL:

Make: Scitec Corporation
Model: MAP 4
Source: Co⁵⁷
Note: This sheet supersedes all previous sheets for the XRF instrument of the make, model, and source shown above.

EVALUATION DATA SOURCE AND DATE:

This sheet is supplemental information to be used in conjunction with Chapter 7 of the HUD *Guidelines for the Evaluation and Control of Lead-Based Paint Hazards in Housing* ("HUD Guidelines"). Performance parameters shown on this sheet are calculated from an EPA/HUD evaluation using archived building components. Testing was conducted on approximately 150 test locations. All of the test locations were tested in February 1996 using two different instruments. One instrument had a new source installed in July 1994 and its strength at the time of testing was calculated as 9.4 mCi. The other instrument had a new source installed in September 1994 and its strength at the time of testing was calculated as 10.6 mCi.

FIELD OPERATION GUIDANCE

OPERATING PARAMETERS:

Performance parameters shown in this sheet are applicable only when operating the instrument under the same conditions as the evaluation testing and using the procedures described in Chapter 7 of the HUD Guidelines. Operating parameters include:

- Manufacturer-recommended warm-up and quality control procedures
- Use the Multifamily Decision Flowchart for determining the presence of lead on a component type in multifamily housing
- Take readings on three locations per component for single-family housing and one location per component for multifamily housing
- Calibration checks are taken in test mode while using the red (1.02 mg/cm²) NIST Standard Reference Material (SRM No. 2579) paint film
- Readings for determining the substrate correction values are taken on bare substrate covered with red (1.02 mg/cm²) NIST SRM paint film
- Lead-based paint is defined as paint with lead equal to or in excess of 1.0 mg/cm².

XRF PERFORMANCE CHARACTERISTICS SHEET
Scitec Corporation; MAP 4

XRF CALIBRATION CHECK:

Chapter 7 of the HUD Guidelines recommends using a calibration check procedure to determine the operating condition of the XRF instrument. For this instrument, calibration checks should be taken in TEST mode. If the observed calibration check average minus 1.02 mg/cm² is greater than the positive (plus) calibration check tolerance value, or less than the negative (minus) calibration check tolerance value, then the instructions provided by the manufacturer should be followed in order to bring the instrument back into control before any more XRF testing is done. This calibration check is estimated to produce an incorrect result (that is, a finding that the instrument is out of calibration) very infrequently - once out of every 200 times this procedure is followed.

minus value = -0.4 mg/cm²
 plus value = +0.2 mg/cm²

WHEN USING UNLIMITED MODE, SUBSTRATE CORRECTION RECOMMENDED FOR:

None

WHEN USING UNLIMITED MODE, SUBSTRATE CORRECTION NOT RECOMMENDED FOR:

Brick, Concrete, Drywall, Metal, Plaster, and Wood

WHEN USING SCREEN OR TEST MODE, FOR XRF RESULTS BELOW 4.0 mg/cm², SUBSTRATE CORRECTION RECOMMENDED FOR:

Drywall, Metal, and Wood

WHEN USING SCREEN OR TEST MODE, SUBSTRATE CORRECTION NOT RECOMMENDED FOR:

Brick, Concrete, and Plaster

SUBSTRATE CORRECTION VALUE COMPUTATION:

Chapter 7 of the HUD Guidelines provides guidance on correcting XRF results for substrate bias. Supplemental guidance for using the red (1.02 mg/cm²) NIST SRM paint film for substrate correction is provided below.

XRF results are corrected for substrate bias by subtracting from each XRF result a correction value determined separately in each house for single-family housing or in each development for multifamily housing, for each substrate. The correction value is an average of XRF readings taken over red NIST SRM (1.02 mg/cm²) paint films at test locations that had been scraped clean of their paint covering. Compute the correction values as follows:

XRF PERFORMANCE CHARACTERISTICS SHEET
Scitec Corporation; MAP 4

- Using the same XRF instrument, take three readings on a bare substrate area covered with the red NIST SRM (1.02 mg/cm²) paint film. Repeat this procedure by taking three more readings on a second bare substrate area of the same substrate covered with the red NIST SRM (1.02 mg/cm²) paint film.
- Compute the correction value for each substrate type by computing the average of all six readings as shown below.

For each substrate type:

$$\left. \begin{array}{l} \text{Correction} \\ \text{Value} \end{array} \right\} = \frac{1^{\text{st}} + 2^{\text{nd}} + 3^{\text{rd}} + 4^{\text{th}} + 5^{\text{th}} + 6^{\text{th}} \text{ Reading}}{6} - 1.02 \text{ mg/cm}^2$$

- Repeat this procedure for each substrate tested in the house or housing development.

INCONCLUSIVE RANGE OR THRESHOLD:

XRF results are classified using either the threshold or the inconclusive range. In single-family housing, an XRF result is the average of three readings taken on a testing combination. (A testing combination is a location on a painted surface as defined in Chapter 7 of the HUD Guidelines). In multifamily housing, an XRF result is a single reading taken on a testing combination. For computing the XRF result, use all digits that are reported by the instrument. For the threshold, results are classified as positive if they are greater than or equal to the threshold, and negative if they are less than the threshold. There is no inconclusive classification when using the threshold. For the inconclusive range, results are classified as positive if they are greater than or equal to the upper limit of the inconclusive range, and negative if they are less than or equal to the lower limit of the inconclusive range. Thresholds and inconclusive ranges were determined for comparing results to the 1.0 mg/cm² standard. For a listing of laboratories recommended by the EPA National Lead Laboratory Accreditation Program (NLLAP) for the analysis of samples to resolve an inconclusive XRF result or additional confirmational analysis, call the National Lead Information Center Clearinghouse on 1-800-424-LEAD.

UNLIMITED MODE READING DESCRIPTION	SUBSTRATE	INCONCLUSIVE RANGE (mg/cm ²)
Results not corrected for substrate bias for unlimited mode readings	Brick	0.9 to 1.2
	Concrete	0.9 to 1.2
	Drywall	0.9 to 1.2
	Metal	0.9 to 1.2
	Plaster	0.9 to 1.2
	Wood	0.9 to 1.2

XRF PERFORMANCE CHARACTERISTICS SHEET
Scitec Corporation; MAP 4

SCREEN MODE READING DESCRIPTION	SUBSTRATE	INCONCLUSIVE RANGE (mg/cm ²)
Results corrected for substrate bias for screen mode readings on drywall, metal, and wood substrates only	Brick	0.9 to 1.1
	Concrete	0.9 to 1.1
	Drywall	0.9 to 1.4
	Metal	0.9 to 1.2
	Plaster	0.9 to 1.1
	Wood	0.9 to 1.3

TEST MODE READING DESCRIPTION	SUBSTRATE	THRESHOLD (mg/cm ²)	INCONCLUSIVE RANGE (mg/cm ²)
Readings corrected for substrate bias for test mode readings on drywall, metal, and wood substrates only	Brick	0.9	None
	Concrete	0.9	None
	Drywall	None	0.9 to 1.4
	Metal	None	0.9 to 1.1
	Plaster	0.9	None
	Wood	None	0.9 to 1.3

INSTRUCTIONS FOR EVALUATING XRF TESTING:

Chapter 7 of the HUD Guidelines recommends several options for evaluating XRF testing. Among those options is the following procedure which may be used after XRF testing has been completed. In single-family housing, an XRF result is the average of three readings taken on a testing combination. (A testing combination is a location on a painted surface as defined in Chapter 7 of the HUD Guidelines). In multifamily housing, an XRF result is a single reading taken on a testing combination. If a multifamily housing development is being retested, randomly select two units from within the development from which the ten testing combinations should be randomly selected. Use either 15-second readings or 60-second readings.

Randomly select ten testing combinations for retesting from each house or from the two selected units.

Conduct XRF retesting at the ten testing combinations selected for retesting.

Determine if the XRF testing in the units or house passed or failed the test by applying the steps below.

Compute the Retest Tolerance Limit by the following steps:

Determine XRF results for the original and retest XRF readings. Do not correct the original or retest results for substrate bias. In single-family housing a result is defined as the average of three readings. In multifamily housing, a result is a single reading. Therefore, there will be ten original and ten retest XRF results for each house or for the two selected units.

Compute the average of the original and re-test result for each of the ten testing combinations.

Square the average for each testing combination.

Add the ten squared averages together. Call this quantity C.

Multiply the number C by 0.0072. Call this quantity D.

XRF PERFORMANCE CHARACTERISTICS SHEET
Scitec Corporation; MAP 4

Add the number 0.032 to D. Call this quantity E.

Take the square root of E. Call this quantity F.

Multiply F by 1.645. The result is the Retest Tolerance Limit.

Compute the overall average of all ten retest XRF results over all ten testing combinations selected for retesting.

Take the difference of the overall average of the ten original XRF results and the overall average of the ten retest XRF results. If the difference is negative, drop the negative sign.

If the difference of the overall averages is less than the Retest Tolerance Limit, the inspection has passed the retest. If the difference of the overall averages equals or exceeds the Retest Tolerance Limit, this procedure should be repeated with ten new testing combinations. If the difference of the overall averages is equal to or greater than the Retest Tolerance Limit a second time, then the inspection should be considered deficient.

Use of this procedure is estimated to produce a spurious result approximately 1% of the time. That is, results of this procedure will call for further examination when no examination is warranted in approximately 1 out of 100 dwelling units tested.

TESTING TIMES:

For screen, test, and confirm modes, the MAP 4 instrument tests until a K-shell result is obtained relative to a level of precision. A result is "positive", "negative" or "retest" as displayed by indicator lights. For the unlimited mode, the MAP 4 instrument tests until a K-shell result is indicated relative to an action level (1.0 mg/cm² for archive testing) and the current precision, or until the the reading is terminated by releasing the trigger. A few unlimited mode readings were terminated because they exceeded the two-minute limit used for archive testing. The following tables provide testing time information for three testing modes. Insufficient information is available to provide this information for confirm mode. All times have been scaled to match an initial 12 mCi source. Note that source strength and factors such as substrate may affect testing times.

UNLIMITED MODE TESTING TIMES (Seconds)						
SUBSTRATE*	ALL DATA			MEDIAN FOR LABORATORY-MEASURED LEAD LEVELS (mg/cm ²)		
	25 th Percentile	Median	75 th Percentile	Pb < 0.25	0.25 ≤ Pb < 1.0	1.0 ≤ Pb
Wood Drywall	3	4	6	4	13	3
Metal	3	4	8	4	9	3
Brick Concrete Plaster	4	5	8	6	6	3

*The general calibration was used for wood, drywall, brick, concrete, plaster. Steel calibration was used for metal. (There are no aluminum samples in the archive facility).

XRF PERFORMANCE CHARACTERISTICS SHEET
Scitec Corporation; MAP 4

TESTING TIMES (continued):

SCREEN MODE TESTING TIMES (Seconds)						
SUBSTRATE*	ALL DATA			MEDIAN FOR LABORATORY-MEASURED LEAD LEVELS (mg/cm ²)		
	25 th Percentile	Median	75 th Percentile	Pb < 0.25	0.25 ≤ Pb < 1.0	1.0 ≤ Pb
Wood Drywall	4	6	7	5	6	7
Metal	4	5	6	5	5	5
Brick Concrete Plaster	11	11	13	11	11	11

*The general calibration was used for wood, drywall, brick, concrete, plaster. Steel calibration was used for metal. (There are no aluminum samples in the archive facility).

TEST MODE TESTING TIMES (Seconds)						
SUBSTRATE	ALL DATA			MEDIAN FOR LABORATORY-MEASURED LEAD LEVELS (mg/cm ²)		
	25 th Percentile	Median	75 th Percentile	Pb < 0.25	0.25 ≤ Pb < 1.0	1.0 ≤ Pb
Wood Drywall	17	22	27	21	20	28
Metal	13	20	23	20	20	20
Brick Concrete Plaster	41	42	52	41	46	43

*The general calibration was used for wood, drywall, brick, concrete, plaster. Steel calibration was used for metal. (There are no aluminum samples in the archive facility).

XRF PERFORMANCE CHARACTERISTICS SHEET
Scitec Corporation; MAP 4

BIAS AND PRECISION:

Do not use these bias and precision data to correct for substrate bias. These bias and precision data were computed without substrate correction from samples with laboratory-measured lead levels less than 4.0 mg/cm² lead. There were 15 testing locations taken in the screen mode with a laboratory-measured lead levels equal to or greater than 4.0 mg/cm² lead. None of these had XRF readings less than 1.0 mg/cm². There were 15 testing locations taken in the test mode with a laboratory-measured lead levels equal to or greater than 4.0 mg/cm² lead. None of these had XRF readings less than 1.0 mg/cm². There were not any testing locations taken in the confirm mode with a laboratory-measured lead levels equal to or greater than 4.0 mg/cm² lead. There were 15 testing locations taken in the unlimited mode with a laboratory-measured lead levels equal to or greater than 4.0 mg/cm² lead. None of these had XRF readings less than 1.0 mg/cm². All testing was done in February 1996 with two different instruments. The following data are for illustrative purposes only. Actual bias must be determined on the site. Inconclusive ranges provided above already account for bias and precision. Units are in mg/cm².

SCREEN MODE READING MEASURED AT	SUBSTRATE	BIAS (mg/cm ²)	PRECISION* (mg/cm ²)
0.0 mg/cm ²	Brick	-0.1	0.3
	Concrete	-0.1	0.3
	Drywall	0.1	0.2
	Metal	0.1	0.3
	Plaster	-0.1	0.3
	Wood	0.0	0.2
0.5 mg/cm ²	Brick	0.0	0.3
	Concrete	0.0	0.3
	Drywall	0.3	0.4
	Metal	0.2	0.3
	Plaster	0.0	0.3
	Wood	0.2	0.4
1.0 mg/cm ²	Brick	0.1	0.4
	Concrete	0.1	0.4
	Drywall	0.5	0.6
	Metal	0.3	0.3
	Plaster	0.1	0.4
	Wood	0.4	0.5
2.0 mg/cm ²	Brick	0.4	0.5
	Concrete	0.4	0.5
	Drywall	0.9	0.8
	Metal	0.5	0.3
	Plaster	0.4	0.5
	Wood	0.7	0.8

*Precision at 1 standard deviation

XRF PERFORMANCE CHARACTERISTICS SHEET
Scitec Corporation; MAP 4

BIAS AND PRECISION (continued):

TEST MODE READING MEASURED AT	SUBSTRATE	BIAS (mg/cm ²)	PRECISION* (mg/cm ²)
0.0 mg/cm ²	Brick	-0.1	0.2
	Concrete	-0.1	0.2
	Drywall	0.1	0.1
	Metal	0.1	0.2
	Plaster	-0.1	0.2
	Wood	0.0	0.1
0.5 mg/cm ²	Brick	-0.1	0.3
	Concrete	-0.1	0.3
	Drywall	0.3	0.4
	Metal	0.2	0.2
	Plaster	-0.1	0.3
	Wood	0.2	0.4
1.0 mg/cm ²	Brick	-0.1	0.3
	Concrete	-0.1	0.3
	Drywall	0.5	0.6
	Metal	0.3	0.2
	Plaster	-0.1	0.3
	Wood	0.4	0.6
2.0 mg/cm ²	Brick	0.0	0.4
	Concrete	0.0	0.4
	Drywall	1.0	0.8
	Metal	0.5	0.2
	Plaster	0.0	0.4
	Wood	0.8	0.8

*Precision at 1 standard deviation

A document titled *Methodology for XRF Performance Characteristic Sheets* provides an explanation of the statistical methodology used to construct the data in the sheets and provides empirical results from using the recommended inconclusive ranges or thresholds for specific XRF instruments. For a copy of this document call the National Lead Information Center Clearinghouse at 1-800-424-LEAD.

This XRF Performance Characteristics Sheet is a joint product of the U.S. Environmental Protection Agency (EPA) and the U.S. Department of Housing and Urban Development (HUD). The issuance of this sheet does not constitute rulemaking. The information provided here is intended solely as guidance to be used in conjunction with Chapter 7 of the *Guidelines for the Evaluation and Control of Lead-Based Paint Hazards in Housing*. EPA and HUD reserve the right to revise this guidance. Please address questions and comments on this sheet to: Director, Office of Lead-Based Paint Abatement and Poisoning Prevention, U.S. Department of Housing and Urban Development, Room B-133, 451 Seventh St. S.W., Washington, DC 20410.

Performance Characteristic Sheet

EFFECTIVE DATE: October 24, 2000

EDITION NO.: 4

MANUFACTURER AND MODEL:

Make: *Radiation Monitoring Devices*

Model: *LPA-1*

Source: ^{57}Co

Note: This sheet supersedes all previous sheets for the XRF instrument of the make, model, and source shown above for instruments sold or serviced after June 26, 1995. For other instruments, see prior editions.

FIELD OPERATION GUIDANCE

OPERATING PARAMETERS:

Quick mode or nominal 30-second standard mode readings.

XRF CALIBRATION CHECK LIMITS:

0.7 to 1.3 mg/cm ² (inclusive)

SUBSTRATE CORRECTION:

For XRF results below 4.0 mg/cm², substrate correction is recommended for:

- Metal using 30-second standard mode readings.

- None using quick mode readings.

Substrate correction is not needed for:

- Brick, Concrete, Drywall, Plaster, and Wood using 30-second standard mode readings

- Brick, Concrete, Drywall, Metal, Plaster, and Wood using quick mode readings

THRESHOLDS:

30-SECOND STANDARD MODE READING DESCRIPTION	SUBSTRATE	THRESHOLD (mg/cm ²)
Results corrected for substrate bias on metal substrate only	Brick	1.0
	Concrete	1.0
	Drywall	1.0
	Metal	0.9
	Plaster	1.0
	Wood	1.0

QUICK MODE READING DESCRIPTION	SUBSTRATE	THRESHOLD (mg/cm ²)
Readings not corrected for substrate bias on any substrate	Brick	1.0
	Concrete	1.0
	Drywall	1.0
	Metal	1.0
	Plaster	1.0
	Wood	1.0

BACKGROUND INFORMATION

EVALUATION DATA SOURCE AND DATE:

This sheet is supplemental information to be used in conjunction with Chapter 7 of the HUD *Guidelines for the Evaluation and Control of Lead-Based Paint Hazards in Housing* ("HUD Guidelines").

Performance parameters shown on this sheet are calculated from the EPA/HUD evaluation using archived building components. Testing was conducted on approximately 150 test locations in July 1995. The instrument that performed testing in September had a new source installed in June 1995 with 12 mCi initial strength.

OPERATING PARAMETERS:

Performance parameters shown in this sheet are applicable only when properly operating the instrument using the manufacturer's instructions and procedures described in Chapter 7 of the HUD Guidelines.

XRF CALIBRATION CHECK:

The calibration of the XRF instrument should be checked using the paint film nearest 1.0 mg/cm² in the NIST Standard Reference Material (SRM) used (e.g., for NIST SRM 2579, use the 1.02 mg/cm² film).

If readings are outside the acceptable calibration check range, follow the manufacturer's instructions to bring the instruments into control before XRF testing proceeds.

SUBSTRATE CORRECTION VALUE COMPUTATION:

Chapter 7 of the HUD Guidelines provides guidance on correcting XRF results for substrate bias. Supplemental guidance for using the paint film nearest 1.0 mg/cm² for substrate correction is provided:

XRF results are corrected for substrate bias by subtracting from each XRF result a correction value determined separately in each house for single-family housing or in each development for multifamily housing, for each substrate. The correction value is an average of XRF readings taken over the NIST SRM paint film nearest to 1.0 mg/cm² at test locations that have been scraped bare of their paint covering. Compute the correction values as follows:

Using the same XRF instrument, take three readings on a bare substrate area covered with the NIST SRM paint film nearest 1 mg/cm². Repeat this procedure by taking three more readings on a second bare substrate area of the same substrate covered with the NIST SRM.

Compute the correction value for each substrate type where XRF readings indicate substrate correction is needed by computing the average of all six readings as shown below.

For each substrate type (the 1.02 mg/cm² NIST SRM is shown in this example; use the actual lead loading of the NIST SRM used for substrate correction):

$$\text{Correction value} = (1\text{st} + 2\text{nd} + 3\text{rd} + 4\text{th} + 5\text{th} + 6\text{th Reading}) / 6 - 1.02 \text{ mg/cm}^2$$

Repeat this procedure for each substrate requiring substrate correction in the house or housing development.

EVALUATING THE QUALITY OF XRF TESTING:

Randomly select ten testing combinations for retesting from each house or from two randomly selected units in multifamily housing. Use either 15-second readings or 60-second readings.

Conduct XRF re-testing at the ten testing combinations selected for retesting.

Determine if the XRF testing in the units or house passed or failed the test by applying the steps below.

Compute the Retest Tolerance Limit by the following steps:

Determine XRF results for the original and retest XRF readings. Do not correct the original or retest results for substrate bias. In single-family housing a result is defined as the average of three readings. In multifamily housing, a result is a single reading. Therefore, there will be ten original and ten retest XRF results for each house or for the two selected units.

Calculate the average of the original XRF result and retest XRF result for each testing combination.

Square the average for each testing combination.

Add the ten squared averages together. Call this quantity C.

Multiply the number C by 0.0072. Call this quantity D.

Add the number 0.032 to D. Call this quantity E.

Take the square root of E. Call this quantity F.

Multiply F by 1.645. The result is the Retest Tolerance Limit.

Compute the average of all ten original XRF results.

Compute the average of all ten re-test XRF results.

Find the absolute difference of the two averages.

If the difference is less than the Retest Tolerance Limit, the inspection has passed the retest. If the difference of the overall averages equals or exceeds the Retest Tolerance Limit, this procedure should be repeated with ten new testing combinations. If the difference of the overall averages is equal to or greater than the Retest Tolerance Limit a second time, then the inspection should be considered deficient.

Use of this procedure is estimated to produce a spurious result approximately 1% of the time. That is, results of this procedure will call for further examination when no examination is warranted in approximately 1 out of 100 dwelling units tested.

BIAS AND PRECISION:

Do not use these bias and precision data to correct for substrate bias. These bias and precision data were computed without substrate correction from samples with reported laboratory results less than 4.0 mg/cm² lead. The data which were used to determine the bias and precision estimates given in the table below have the following properties. During the July 1995 testing, there were 15 test locations with a laboratory-reported result equal to or greater than 4.0 mg/cm² lead. Of these, one 30-second standard mode reading was less than 1.0 mg/cm² and none of the quick mode readings were less than 1.0 mg/cm². The instrument that tested in July is representative of instruments sold or serviced after June 26, 1995. These data are for illustrative purposes only. Actual bias must be determined on the site. Results provided above already account for bias and precision. Bias and precision ranges are provided to show the variability found between machines of the same model.

30-SECOND STANDARD MODE READING MEASURED AT	SUBSTRATE	BIAS (mg/cm ²)	PRECISION ¹ (mg/cm ²)
0.0 mg/cm ²	Brick	0.0	0.1
	Concrete	0.0	0.1
	Drywall	0.1	0.1
	Metal	0.3	0.1
	Plaster	0.1	0.1
	Wood	0.0	0.1
0.5 mg/cm ²	Brick	0.0	0.2
	Concrete	0.0	0.2
	Drywall	0.0	0.2
	Metal	0.2	0.2
	Plaster	0.0	0.2
	Wood	0.0	0.2
1.0 mg/cm ²	Brick	0.0	0.3
	Concrete	0.0	0.3
	Drywall	0.0	0.3
	Metal	0.2	0.3
	Plaster	0.0	0.3
	Wood	0.0	0.3
2.0 mg/cm ²	Brick	-0.1	0.4
	Concrete	-0.1	0.4
	Drywall	-0.1	0.4
	Metal	0.1	0.4
	Plaster	-0.1	0.4
	Wood	-0.1	0.4

¹Precision at 1 standard deviation.

CLASSIFICATION RESULTS:

XRF results are classified as positive if they are greater than the upper boundary of the inconclusive range, and negative if they are less than the lower boundary of the inconclusive range, or inconclusive if in between. The inconclusive range includes both its upper and lower bounds. Earlier editions of this *XRF Performance Characteristics Sheet* did not include both bounds of the inconclusive range as "inconclusive." While this edition of the Performance Characteristics Sheet uses a different system, the specific XRF readings that are considered positive, negative, or inconclusive for a given XRF model and substrate remain unchanged, so previous inspection results are not affected.

DOCUMENTATION:

An EPA document titled *Methodology for XRF Performance Characteristic Sheets* provides an explanation of the statistical methodology used to construct the data in the sheets, and provides empirical results from using the recommended inconclusive ranges or thresholds for specific XRF instruments. For a copy of this document call the National Lead Information Center Clearinghouse at 1-800-424-LEAD. A HUD document titled *A Nonparametric Method for Estimating the 5th and 95th Percentile Curves of Variable-Time XRF Readings Based on Monotone Regression* provides supplemental information on the methodology for variable-time XRF instruments. A copy of this document can be obtained from the HUD lead web site, www.hud.gov/lea.

This edition of the XRF Performance Characteristic Sheet was developed by QuanTech, Inc., under a contract from the U.S. Department of Housing and Urban Development (HUD). HUD has determined that the information provided here is acceptable when used as guidance in conjunction with Chapter 7, Lead-Based Paint Inspection, of HUD's *Guidelines for the Evaluation and Control of Lead-Based Paint Hazards in Housing*.



CHAPTER 6

LIABILITY AND INSURANCE ISSUES

Objectives	6-3
Learning Tasks	6-4
Introduction	6-5
Sources of Civil Legal Liability	6-6
Administrative Sanctions and Criminal Penalties.....	6-7
Civil Lawsuits	6-8
Tort liability.....	6-9
Contract liability	6-11
Legal Considerations of Insurance	6-13
Errors and omissions insurance	6-13
General liability insurance	6-13



Inspecting for Lead-based Paint





Liability and Insurance Issues

Objectives

The objectives of this chapter are to:

- provide lead inspectors with knowledge of potential legal liabilities and responsibilities of professionals involved in lead-based paint inspections;
- provide an understanding of criminal penalties and administrative sanctions;
- provide an overview of the need for and importance of contracts; and
- provide a brief awareness of insurance issues.



Learning Tasks

After completing this chapter, inspectors should be able to:

- understand their legal responsibilities;
- understand the sources of civil legal liability;
- understand contract language; and
- understand the purpose, limitations, and availability of insurance.



Liability and Insurance Issues

Introduction

Persons who engage in lead-based paint inspections need to be aware of the legal responsibilities that they have. This section deals with these issues briefly. Sources of civil legal liability, criminal penalties, administrative sanctions, and civil lawsuits will be discussed in this chapter.



Sources of Civil Legal Liability

The three sources of civil legal liability are

- statutory law,
- administrative law,
- common law.

Within the area of statutory law there are federal, state, and local authorities. As mentioned in Chapter 4, Congress passed the Lead-based Paint Poisoning Prevention Act (LBPPPA) in 1971. Of special interest to inspectors is Title 42, Section 4882, and its regulations. Additionally, Congress passed Title X in 1992, which focused more federal attention on the issue of preventing childhood lead poisoning.

Various state and local governments have enacted lead-based paint-related legislation, and some jurisdictions have sections of their building codes that are relevant. In addition, the services provided by inspectors would also be covered by consumer protection laws. Inspectors are urged to seek out information regarding such legislation from local authorities.

Administrative law relates to regulations that are put into force by various federal, state and local authorities. These regulations also have the force of law. In addition to EPA, HUD and other federal agencies with jurisdiction over the LBP issue, many other agencies can issue regulations that affect the inspector. These include both federal and state departments of public health, labor, and commerce. In addition, the local health, sanitary, and building codes may have regulations that relate to lead-based paint.

Common law is related to decisions by state and federal courts that interpret statutes and regulations. Such legal cases may relate to the duties and responsibilities of home owners, landlords, tenants, inspectors, and contractors.

An inspector is subject to several sources of liability.



Administrative Sanctions and Criminal Penalties

Failure to adhere to the statutes and regulations applicable to lead-based paint inspections could result in a range of penalties or sanctions by governmental authorities against the inspector. These can include the following:

- fines;
- loss of license;
- criminal prosecution for causing injury to a child;
- injunctions—prohibition against doing business; and/or
- cease work orders.

Failure to adhere to the statutes and regulations applicable to LBP inspections could result in a range of penalties or sanctions.



Civil Lawsuits

Civil lawsuits may be brought by an individual or company (the plaintiff) in order to obtain compensation for, or relief from, harm caused by another person or company (the defendant). Compensation requested by plaintiffs is generally referred to as damages. In addition, plaintiffs may seek injunctive relief through which a defendant can be compelled to perform certain activities or cease the activity causing injury.

Civil lawsuits may arise in the context of lead-based paint inspections under theories of both *tort* and *contract*. Tort law is defined as a civil "wrong" or breach of a standard of behavior or failure to use reasonable care for which a court orders a monetary remedy called "damages." In contrast, contract law relates to situations in which a person breaks or "breaches" a legally enforceable written or oral agreement or contract. In such situations, the courts could order a variety of remedies, including monetary damages.

Courts also provide specific remedies when a person fails to fulfill the duties that are required of them under lead poisoning prevention statutes; consumer protection laws; state or local building or sanitary codes; and labor law regulations.

The following is a list of possible damages that a court might impose if tort or contract liability is determined to be present:

- past and future medical expenses;
- remedial education and vocational rehabilitation costs;
- loss of learning capacity of child;
- pain and suffering;
- general damages—loss of child's quality of life;
- property damages;
- stipulated penalties (if stated in the contract);
- consequential damages;
- possible punitive/multiple damages;
- attorneys' fees.

One party may also be required to *indemnify* another for damages arising from contract or tort liability. Indemnification is when one party, either by an expressed written or oral agreement or by implication, promises to protect the other party in a contract by paying for ("indemnifying") any damages arising from the contract work.

Civil lawsuits may arise out of tort or contract liability.

An inspector may be asked to indemnify the client for damages arising from liability.



Liability and Insurance Issues

Tort liability

A lead inspector could be liable under tort law if any of the following are found to be true:

- *Negligence*—if a lead inspector or lead abatement contractor fails to fulfill all of his/her duties or fails to exercise the standard of care to which a reasonable inspector or contractor would adhere, he/she may be held liable for acting negligently.
- *Vicarious Liability*—an employer is legally responsible for the acts, omissions, and wrongful behavior (“torts”) of his/her employees.

In order to hold the defendant legally liable for a tort claim, the injured person (the plaintiff) must prove four “elements.” These elements are:

- that the defendant committed an *act or omission* that
- violated a *duty* which the defendant owed to the plaintiff and which act or omission
- was the *cause of*
- an *injury* to the plaintiff.

The “duty” owed by an inspector will always be controlled by the relevant “standard of care.” An inspector or contractor must always act as a reasonable, competent inspector or contractor would have acted, given all the circumstances of the situation, and at the minimum, in accordance with all applicable industry standards. Failure to so act is, at the least, strong evidence of negligence.

The following is a listing of duties owed by lead inspectors to their clients:

1. The inspector has a legal duty to do a complete, thorough, and accurate inspection job in accordance with:
 - all applicable federal, state, and local statutes and regulations,
 - the current state of knowledge in the industry, and
 - current industry standards.
2. The applicable statutes, regulations and standards, are all a floor for behavior, not a ceiling.

These duties are owed to property owners; tenants; housing authority officials; local boards of health and other relevant government agencies; other contractors; and your own workers.

Whether an inspector has acted as a reasonable, competent inspector would have acted under all the relevant circumstances of the situation is determined on a case-by-case basis by a jury. In determining whether there has been a breach of any duty, the courts will consider the training and expertise that a reasonable lead inspector should have and the

An inspector must always act as a reasonable, competent inspector would have acted.

The applicable statutes, regulations and standards are a floor for behavior, not a ceiling.



The EPA rules and the HUD *Guidelines* can be considered the minimum standard of care that must be met.

Keep a comprehensive paper trail.

Don't take shortcuts!

current knowledge available in the industry. Property owners may require or insist on indemnification, which should be put into the contract if it is agreed upon.

The HUD *Guidelines* and the EPA work practice standards can be considered as the minimum standard of care that must be met when inspectors and others are doing lead inspections or hazard control work. Inspectors have a duty to provide a standard of care in their work, but this concept is a flexible and changing one. For example, merely complying with the HUD *Guidelines* does not guarantee that you have met the required standard of care, if a reasonable lead-based paint inspector under the particular circumstances involved would have taken precautions or other steps beyond those required by the HUD *Guidelines*.

In order to avoid legal liability under tort law, the inspector should do the following:

- Be familiar with and follow all applicable laws, regulations, and industry standards.
- Carefully screen and train workers and co-workers. Develop and use a written policy, procedures, and training manual for all workers.
- Provide complete and comprehensive explanations of work in written form, including all dangers and hazards, to clients.
- Give written job descriptions that specify exactly what you will do, what methods you will use, what results you will achieve, and within what time frame.
- Keep abreast of new developments.
- Keep a comprehensive "paper trail." Keep detailed, dated written records of everything, including training, inspection procedures, etc., for at least twenty (20) years.
- Provide close supervision of work on-site.
- Do not take shortcuts! This may be interpreted as falling below the required standard of care.



Liability and Insurance Issues

Contract liability

Contract liability is based on legally enforceable agreements or contracts, either written or oral. Oral agreements are enforceable; however, the outcome in such cases depends on the credibility of the involved parties as the court will find for the party that it believes to be telling the truth. In contrast, written contracts are controlling.

Disputes arise when one party to an agreement defaults. A default occurs when the party of interest does not carry out or complete his or her end of the bargain. In such cases, the court may order any remedies, including monetary damages, against the defaulting party, putting the innocent injured party back to the same position as if the default (or contract breach) never happened. Innocent third parties, not part of the contract, who are injured by one of the contracting parties may also be able to sue one or both of the contracting parties.

In order to avoid contract liability, inspectors should follow the following guidelines:

- Use written contracts that detail whose responsibility it is for what work, with reasonable time and cost estimates. Always keep a signed copy of contracts.
- Confirm *all* oral agreements, change orders, or disputed issues by writing a letter to the other party/parties.
- Develop and use written forms for everything: estimates; inspections; reinspections; notices to property owners and/or tenants; contracts; letters of compliance; notices regarding results of the inspection.
- Have clients sign "satisfaction" forms upon completion of the work.
- Promise only what can be delivered. The only time an inspection report should report a dwelling is *lead-based paint free* is when rental dwellings are inspected for the purposes of receiving lead-based paint free certification for exemption from the HUD/EPA real estate notification and disclosure rule (24 CFR Part 35 and 40 CFR Part 745). *Never say a dwelling is lead free.* The report should only say:
 - a property was inspected for lead-based paint on "xxx" date, and list the surfaces found to contain lead at or above the federal (or local) standard, or
 - no surfaces tested contained lead-based paint based on the federal (or local) standard used for the inspection.
- Include detailed, but reasonable and achievable specifications in each contract, including realistic time schedules.
- Follow applicable federal, state, and industry standards.

Contracts are legally enforceable agreements, either written or oral.

Confirm all oral agreements, change orders, or disputed issues in writing.

Never say a dwelling is lead-free!



Inspecting for Lead-based Paint

- Establish and follow set procedures that will be used on every job. Write them down, and give them to clients/customers and employees. Inspectors should be able to testify in any court case that on every job it is company policy to always do a, b and c, that never do d, e, or f, and that each certified/licensed inspector have been specially trained to do x, y, and z.
- Have a lawyer review forms and contracts.

Given that contracts are legally binding and enforceable agreements between parties (i.e., the lead inspector and the client), lead-based paint inspectors should be specific about their contract terms. Implied contracts often insufficiently specify contract terms. Expressed contracts are written and allow for specificity of contract terms and agreements. Liability issues may result from any type of contract.

**Expressed contracts
are better than
implied contracts.**



Legal Considerations of Insurance

Obtaining professional liability insurance is a method via which a lead-based paint inspector (the professional) may secure protection from possible litigation related to the performance of his or her professional duties. Lead inspectors may be required to obtain liability insurance. This is a means to potentially insure financial security should significant claims surface. Certain states and local laws require a specified amount of general liability insurance.

The professional may be obligated to indemnify and defend the owner against claims brought against the owner as the result of the inspector's work. Therefore, it may be necessary to include an indemnity clause in the contract. Likewise, inspectors may need to acquire such insurance to protect themselves against claims. Work performed in accordance with specifications and applicable regulations may protect the inspector from liability.

Obtaining insurance generally adds to the inspector's cost. The owner may often bear the expense of the insurance. Given the cost and availability of insurance, owners may opt to drop insurance requirements in order to obtain professional services. Although the owner may not require the inspector to be insured, state or local laws might. If such is the case, the inspector should be insured accordingly.

Errors and omissions insurance

Inspectors and risk assessors will normally look for "errors and omissions" insurance to protect them against misjudgments made during lead-based paint inspections or risk assessments. The mistake may take the form of an inadvertent error (miscalculation of data) or the form of an unintentional omission of sorts (i.e., not enough testing combinations tested). Errors and omissions (E&O) coverage is written for specific professions. Many professionals (e.g., architect, engineer, designer) have E&O coverage to protect them; however, lead-related professionals may have difficulty obtaining full coverage due to increased exposure for loss in their activities. If E&O insurance is found by the lead professional, the coverage might be very expensive.

General liability insurance

General liability insurance, another type of coverage that inspectors and risk assessors might pursue, is available and may serve as protection for events that occur during the inspection. As the name implies, general liability coverage is suitable for situations brought about by general negligence. The drawback to this type of insurance is that it will likely contain a pollution exclusion, rendering the policy essentially ineffective

Obtain professional liability insurance.

E&O insurance protects the inspector against misjudgment made during the inspection.



**Occurrence
Insurance will pay
for injuries which
occurred during the
policy period.**

**Claims-made
policies provide
coverage during the
policy's effective
period.**

for lead-related concerns. Lead liability issues are constantly being addressed in the courts and therefore are constantly changing.

When reviewing available insurance the inspector must consider whether the insurance is "occurrence" or "claims made." True "occurrence" coverage is rare. This type of coverage allows for claims to be made (filed) at any time, as long as the injury/illness/problem occurred during the effective period of the policy. Claims-made policies generally provide coverage during the policy's effective period. In order to file a claim under a claims-made policy, the injury/illness/problem must have occurred and the claim filed during the policy's effective period. The inspector should always carefully review the policy, to check for conditions and exclusions that may negate coverage and to ensure the provision of adequate coverage.



DIVISION OF RADIATION PROTECTION
APPLICATION FOR RADIOACTIVE MATERIAL LICENSE

INSTRUCTIONS: Complete Items 1 through 16, using additional sheets as necessary. Refer to the accompanying licensing guide for instruction concerning completion of this form. Item 16 must be completed on all applications. Mail one copy to: Chief, Radioactive Materials Section, Division of Radiation Protection, 3825 Barrett Drive, Raleigh, N.C., 27609-7221. Upon approval of this application, the applicant will receive a Radioactive Materials License issued in accordance with the requirements contained in Chapter 104E of the General Statutes and Chapter 11, Title 15A of the North Carolina Administrative Code.

<p>1.(a) NAME AND MAILING ADDRESS OF APPLICANT. Mecklenburg County Health/Mental Health and Community Services 700 N. Tryon Street Suite 208 Charlotte, NC 28202-2236</p> <p>(b) TELEPHONE NUMBER (704) 336 - 5101</p> <p>(c) FACSIMILE NUMBER (704) 336 - 6894</p>	<p>1.(d) PHYSICAL ADDRESS(ES) AT WHICH RADIOACTIVE MATERIAL WILL BE USED (include temporary jobsites if applicable). 700 N. Tryon Street Suite 208 Charlotte, NC 28202-2236 and at temporary job sites throughout Mecklenburg County.</p>
<p>2. DEPARTMENT(S) TO USE RADIOACTIVE MATERIAL. Public Health Pest Management and Environmental Services Program</p>	<p>3. PREVIOUS LICENSE NUMBER(S). New Licence</p>
<p>4. INDIVIDUAL USER(S). Alan Huneycutt Dennis Salmen</p>	<p>5. RADIATION PROTECTION OFFICER. Dennis Salmen</p>

SUBMIT ITEMS 6 THROUGH 15 ON 8 1/2" X 11" PAPER. THE TYPE AND SCOPE OF INFORMATION IS DESCRIBED IN THE LICENSE APPLICATION GUIDE.

<p>6.(a) RADIOACTIVE MATERIAL (Element and mass number of each).</p>	<p>(b) CHEMICAL AND/OR PHYSICAL FORM AND MAXIMUM NUMBER OF MILLICURIES OF EACH FORM THAT YOU WILL POSSESS AT ANY ONE TIME (If sealed source(s), also state the manufacturer, model number, and number of sources).</p>
<p>7. DESCRIBE THE PURPOSE FOR WHICH RADIOACTIVE MATERIAL WILL BE USED. (If radioactive material is for "human use," Supplement A MUST be completed in addition to this item).</p>	
<p>8. TRAINING OF EACH INDIVIDUAL NAMED IN ITEM 4.</p>	<p>9. EXPERIENCE WITH RADIATION (Actual use of radioisotopes or equivalent experience).</p>
<p>10. RADIATION DETECTION INSTRUMENTS AVAILABLE FOR USE.</p>	<p>11. METHOD, FREQUENCY, AND STANDARDS USED IN CALIBRATING INSTRUMENTS LISTED IN ITEM 10.</p>
<p>12. FILM BADGES, TLD's, DOSIMETERS, AND BIOASSAY PROCEDURES USED.</p>	<p>13. FACILITIES AND EQUIPMENT.</p>
<p>14. RADIATION PROTECTION PROGRAM.</p>	<p>15. WASTE DISPOSAL.</p>

CERTIFICATION (MUST be completed by the applicant. See licensing guide for detailed instructions).

16. **The applicant and any official executing this certificate on behalf of the applicant named in Item 1, certify that all information contained herein, including any supplements attached hereto, has been prepared in conformity with all applicable North Carolina Laws and Regulations and is true and correct to the best of our knowledge and belief.**

BY: Robert D. Cobb 3-20-98
 (Signature of Certifying Official and date signed)

Robert Cobb Division Head
 (Printed name and title of certifying official)

Revised 1/98

MEMORANDUM TO ALL LICENSEES

This application for a North Carolina Radioactive Materials License shall be signed by a top executive of your organization. You may wish to designate a responsible person or persons within your organization who deals directly with radioactive materials to sign future amendment applications to this license.

Radioactive materials amendment applications shall be signed by the following individuals(s):

Name: Dennis Salmen Title: Program Chief

Phone Number: 704-336-5554

Name: _____ Title: _____

Phone Number: _____

Please list the following, if applicable, to your organization, with Title and/or Specialty:

Radioisotope Committee, or Safety Committee:

Signature and Title of Certifying Official:

Robert D. Cobb

Signature

-- Robert D. Cobb

Name (print)

Division Head

Title

Attachments to Application for Radioactive Material License

- 6) Cadmium- 109
- 6b) One sealed source, Niton Corporation, See attachment #1A manufacturers list for model #s. Source not to exceed 50 mCi.
- 7) To be used in a portable XRF Spectrum Analyzer, Niton model XL-309 (#500-305R), to quantify the amount of lead in paint, soil, dust, and other surfaces/materials
- 8,9) See attachment 1
- 10,11) Not applicable
- 12) **Personal exposure levels must be monitored utilizing NRC or approved suppliers accredited by the National Voluntary Laboratory Accreditation Program (NVLAP). All licensed operators are required, by policy, to wear dosimeters which are either; 1) monthly film badges or 2) monthly or quarterly Thermoluminescent Dosimeters (TLD). These must be worn at all times the unit is being handled (operation, wipe test, shipping preparation, etc.).**
- Badges/TLDs' are not transferrable and are individually assigned. Badges/TLDs will be serviced monthly by the attached vendor.
- 13a) Floor plan- See attachment 2
- 13b) The gauge will be stored in a locked cabinet within a locked office in Suite 208 of the aforementioned address. Access to the building at this address is available during business hours to the general public, employees, and clients. After business hours, a keypad locking system allows access only to those who have an individual code. The RSO has such a code. The building is armed with an alarm system which, when activated, is responded to by County Security.
- Access to the referenced suite during business hours is by a manned front desk area or by a keypad cipher lock combination (employees access only including the two listed gauge users). Access to the suite after business hours is by key or by the cipher lock. The RSO has both while the second gauge user only has access by the cipher lock.
- Access to the locked office is by key-lock which (5)-individuals, not including the gauge users, have access to. Four of these staff are management personnel while the fifth would be a maintenance person. The locked cabinet is by key lock which only the listed gauge users (one being the RSO) have access to.
- 13c) County policy requires that all employees utilize proper safety procedures when handling radioactive materials and that all activities relating to the procurement, shipping,

receiving, handling, operation, storage, monitoring, calibration, and administration of such materials be thoroughly documented in accordance with applicable federal and state laws and regulations.

This policy encompasses operator training and licensing, responsibilities of the Radiation Safety Officer (RSO), emergency procedures, recordkeeping, and equipment testing procedures. The radiation administration policy ensures that all operating personnel are:

- Thoroughly familiar with prescribed safe handling techniques and emergency procedures for radioactive materials.
- Fully informed of the hazards posed by exposure to radioactive materials
- Thoroughly familiar with state and federal laws and regulations regarding radiation protection.

These procedures are consistent with the philosophy described in the U.S. Nuclear Regulatory Commission's Regulatory Guide 8:10, Operating Philosophy for Maintaining Occupational Radiation Exposure as Low as Reasonably Achievable. This document states, in part, that persons engaged in activities under licenses issued by the NRC or state regulatory agency shall make every effort to maintain radiation exposure and releases of radioactive material in effluents as low as reasonable achievable (ALARA). See #14 for elements.

(See attachment 6- Decay Chart)

While in use, the gauge, the XRF exposure could be 0.5 mr/hour at 30 cm. Therefore, members of the public will be required to maintain a minimum distance of 90-120 cm. Exposure to minors will be particularly restricted/addressed to ensure none occurs.

(See attachment 5-Exposure Diagram)

- 13d) Both the locked cabinet and the locked office will bear the following radiation posting with the radiation symbol:

**CAUTION
RADIATION AREA**

This complies with 15A NCAC .1624. A "Notice to Employees" agency form will be posted in the office along with how various prescribed documents in the notice (and 15A NCAC .1002) may be examined. A copy of 15A NCAC 11 will be locked in the cabinet.

- 13e) When transported to a temporary jobsite in a passenger vehicle, the shipping container with the Niton will be kept in the trunk. When a station wagon, panel truck, or pickup truck with a service body is used, the device will be secured so that it cannot slide around. When a pickup truck without inside storage is used, the device will be secured to the bed of the vehicle to prevent movement and in such a way to prevent removal by a passerby.

When transported by passenger vehicle, the license will comply with DOT regulations 49CFR 173.421-1 and 173.422. A copy of the attached notice will be laminated and attached to the case.

- 13f,g) An Accountability Record (form B) will be completed by all authorized users when the instrument is removed or returned to permanent storage. The form will be kept in a convenient, accessible location known to licensed users, RSO, and management. The device will remain in the possession of the user at all times when removed from permanent storage. During work breaks, the instrument will be stored in a locked vehicle trunk or cab, if transported and left unattended.

Overnight storage away from the permanent facility will be in a locked vehicle trunk or cab.

- 13i) The local fire department will be notified of the storage location of the device.
- 13j) The physical address is a County building known as the Hal Marshall building which contains offices, laboratories, meeting areas, and other work-related facilities for county employees and clients.

14) **OPERATIONS**

Dosimetry

Personal exposure levels must be monitored utilizing NRC or approved suppliers accredited by the National Voluntary Laboratory Accreditation Program (NVLAP). All licensed operators are required, by policy, to wear dosimeters which are either; 1) monthly film badges or 2) monthly or quarterly Thermoluminescent Dosimeters (TLD). These must be worn at all times the unit is being handled (operation, wipe test, shipping preparation, etc.).

Badges/TLDs' are not transferrable and are individually assigned. Badges/TLDs will be serviced monthly by the attached vendor.

(See attachment 3)

Duties Of The Radiation Safety Officer (RSO)

The RSO has the primary responsibility for the radiation protection program, including:

- Maintenance of source inventory, wipe or leak test, (form A) and dosimetry records.

- Knowledge of the whereabouts of the Niton instrument(s) at all times and maintenance of the appropriate records.
- Full knowledge of shipping, storage, and emergency procedures.
- Annual Radiation Protection Review. Form from DRP Publication L-001 will be used to perform review

The RSO must maintain all documents and records relating to the instrument, including but not limited to:

1. **Company License, Device Registration and Administrative Records**
 - a. Company personnel licenses.
 - b. Device registration(s) for instruments in possession
 - c. Training Certification (certificates) for all operators of the instrument(s).
 - d. Reciprocity letters (if applicable) from other states where device is transported or used.
 - e. Official correspondence from the state (inspection reports),
 - f. State Regulations concerning device.
2. **Shipping and Receiving Records**
 - a. Copy of shipping documents (inbound and outbound).
 - b. Copy of license of any persons the device is transferred to outside of County.
3. **Storage and Maintenance records**
 - a. Leak or swipe test reports (every 6 months) (form A).
 - b. Physical inventory records (every 3 months).
 - c. Dosimetry reports.
 - d. Instruments accountability records (form B).

Licensed Operators

Only factory trained/licensed personnel licensed by the DRP, with full knowledge of regulations, emergency procedures, and safe handling techniques regarding radiation protection, may operate, ship, receive, and have access to the device. Annual refresher training is given to all certified operators.

Licensed operators are directly responsible for the safe use and storage of the Niton. Each operator must be familiar with the material in this manual and the Niton Operation Manual. The license operator must keep the RSO informed of the location of radioactive sources at all times. State Radiation Control Unit inspectors want to visually see the sources or look at written records noting the exact location of sources during their periodic inspections. If the exact address where the Niton device will be used is known in advance, it must be noted before leaving the office, or, if not known, must be forwarded to the RSO as soon as it is known.

Required Niton License

All Niton devices containing active radioactive sources are registered with the appropriate federal agency. Niton devices with cadmium-109 sources are listed in the Radioactive Material Reference Manual, published by the Bureau of Radiological Health (a Department of the Food and Drug Administration).

States fall into two categories in regard to licensing jurisdiction: "Agreement" states and "Non-Agreement" states. Agreement states have entered into an agreement with the NRC to assume licensing jurisdiction. Non agreement states have no state agency with the jurisdiction to license the use of radioactive devices. In these states, a license to use the Niton is granted by the NRC.

The license to use a Niton is issued to the prospective user by the appropriate licensing agency.

Leak Test

The Niton system must be physically inspected to verify location every three months and leak tested every six month. Leak test kits will be supplied and evaluated by Niton or by a testing laboratory licensed to this work. See attachment 3 for vendor. Results of both the quarterly inventory and the semi-annual leak test must be recorded on the SOURCE INVENTORY SHEET.(form A). Results of the leak tests will be returned to the county by the firm performing the analysis and kept on file by the RSO.

See attachment 4 for leak test directions. This container must be marked

"RADIOACTIVE MATERIALS-NO LABEL REQUIRED".

Records of leak test results should be kept in units of nanocuries and maintained for inspection. Any leak test revealing the presence of 0.005 microcuries or more of removable radioactive material must be reported to the state radiation regulatory agency within five days of receipt of the test. This report should include a description of the defective source or device, the results of the test, and the corrective action taken.

Prior to being mailed, the contents and packing must be checked with a survey instrument. The radiation at any point on the surface must not exceed a dose greater than 0.5 millirem per hour in order to comply with U.S. Postal regulations.

Recordkeeping

All records will be retained until license termination and at least 2 years thereafter, or as specified by the DRP.

These logs and records will be maintained in duplicate hard copy in 2 separate locations and in computer storage as appropriate with mandated backup schedules.

Maintenance

General maintenance (cleaning, wipe test, etc.) is performed by the authorized gauge user. All other maintenance will be performed by the manufacturer on a scheduled basis or as gauge operation requires such.

Fetal Dose Policy

All woman who are authorized users are required by policy to notify the RSO when a pregnancy is identified. All pregnant users will be required to wear an abdominal film badge or TLD in addition to other required dosimetry devices. The Fetal Dose Policy form must be executed as soon as notification is made.

Shipping and Transportation

A copy of the license, the U.S. DOT Compliance Statement (see attachment 8), the instruction manual, emergency procedures, and the emergency contact list (see Emergency section) shall remain with the gauge at all times.

All packaging and shipping will be performed by the requirements in US DOT regulations in 49 CFR Part 172 and 49 CFR Part 173, Subpart I. The county will adopt the model bill of lading listed in DRP Publication L-001, Appendix D.

Emergency Procedures

The procedures herein address accidents as well as loss or theft. They are as follows.

Accidents

Vehicle accidents (no observable damage to gauge)

- 1) If a vehicle accident during transportation of the gauge, the user will stay with the vehicle, visually inspecting case or instrument for damage. If it does not appear damaged, lock in case and return to the office.
- 2) Contact the RSO immediately when the accident occurs.
- 3) A wipe test will be performed upon returning the gauge to permanent storage. If the test proves positive, it will be returned to Niton until it passes the < .03 mR/hour factory radiation profile. The RSO will then report the incident to the DRP, as appropriate, in compliance with 15A NCAC .1646 and .1647.

Vehicle accidents (observable damage)

- 1) If gauge is damaged, dented, flooded, or abused, then immediately secure the area by roping off a 10 foot radius around the vehicle, keeping all unauthorized persons out of the secured area. Use the following Emergency Contact List to contact all parties.

RSO (Dennis Salmen):	(704) 334-4941 , (704) 580-0674
DRP:	(919) 571-4141
State Patrol:	911
Fire Department:	911
Niton Corp.	(800) 875-1578

- 2) Once qualified radiation experts are on site with the appropriate survey meters to determine if radioactive material is lost, etc., they will determine how safe site is, remove contaminated material if present, and prepare damaged equipment for shipment to factory, disposal, etc.
- 3) If no contamination or source damage is determined and gauge is released back to user, the user will contact Niton RSO to determine shipping procedures, other than already detailed.

Non-vehicle accidents (no observable damage)

- 1) If accident occurs (water, fire, dropped, penetrated, etc.) during transportation or use of the gauge, the user will stay with the instrument, visually inspecting case or instrument for damage. If it does not appear damaged, lock in case and return to the office.
- 2) Contact the RSO immediately when the accident occurs.

- 3) A wipe test will be performed upon returning the gauge to permanent storage. If the test proves positive, it will be returned to Niton until it passes the < .03 mR/hour factory radiation profile. The RSO will then report the incident to the DRP, as appropriate, in compliance with 15A NCAC .1646 and .1647.

Non-vehicle Accidents (observable damage)

- 1) If gauge is damaged, dented, flooded, or abused, then immediately secure the area by roping off a 10 foot radius around the gauge, keeping all unauthorized persons out of the secured area. Use the following Emergency Contact List to contact all parties.

RSO (Dennis Salmen):	(704) 334-4941 , (704) 580-0674
DRP:	(919) 571-4141
State Patrol:	911
Fire Department:	911
Niton Corp.	(800) 875-1578

- 2) Once qualified radiation experts are on site with the appropriate survey meters to determine if radioactive material is lost, etc., they will determine how safe site is, remove contaminated material if present, and prepare damaged equipment for shipment to factory, disposal, etc.
- 3) If no contamination or source damage is determined and gauge is released back to user, the user will contact Niton RSO to determine shipping procedures, other than already detailed.

Loss or Theft

The Emergency Contact List will immediately be contacted. Precautions are always in place to minimize this occurrence including:

- When gauge not in use, keep in locked storage area or vehicle trunk
- Always keep device in shipping container when not in use
- Always keep gauge in your possession

- 15) Any required disposal of the gauge or source will be by return to the manufacturer, Niton Corp. Scheduled source replacement is also done by the manufacturer (see enclosed policy memo- attachment 9). The DRP will be notified prior to any permanent disposal of an instrument or gauge, exclusive of regularly scheduled source replacement.

ADDENDUM

Directions to Location

Take **I-40 West** from Raleigh to Greensboro, then proceed **South on I-85** to I-77 in Charlotte. Then proceed **South on I-77**, go **approximately 1½ miles**, **exit** on Brookshire Freeway/ Highway 74 East Exit. Travel **1½ miles**, exiting at Tryon Street/Church St exit. Proceed to 2nd stop light (**N.Tryon Street**) and **turn right**. 700 N.Tryon Street is immediately on the right.

Suite is located on **second floor**.



ENVIRONMENTAL RESEARCH AND MEASUREMENT PRODUCTS FOR RADON AND LEAD

Please include on your license for NITON XRF Spectrum Analyzers the following suppliers of radioactive sources:

- Source A: Cadmium 109 - Sealed source
Isotope Products Laboratories
1800 North Keystone Street
Burbank, CA 91504
Model XFB Series 3205
No single source to exceed 50 millicuries.
- Source B: Cadmium 109 - Sealed source
New England Nuclear (Dupont)
331 Treble Cove Road
N. Billerica, MA 01862
Model NER-467
No single source to exceed 50 millicuries.
- Source C: Cadmium 109 - Sealed source
Amersham
2636 S. Clearbrook Drive
Arlington Heights, IL 60005
Model CUC.D1
No single source to exceed 50 millicuries.
- Source D: Cadmium 109 - Sealed source
North American Scientific
7435 Greenbush Avenue
N. Hollywood, CA 91605
Model IND 1602
No single source to exceed 50 millicuries.

P.O. Box 368 • 74 Loomis Street • Bedford, MA 01730-0368 • 617-275-9275 • 800-875-1575
Fax: 617-275-1917 • e-mail: NITON@eol.com • <http://www.tiac.net/users/niton>

NITON®

CORPORATION

Certificate of Achievement

*Dennis Salmen
Mecklenburg County Health Dept.*

*has successfully completed the Manufacturer's Training Course for the
NITON Spectrum Analyzer and is now certified
in radiation safety and monitoring, measurement technology,
and machine maintenance of the NITON XRF Spectrum Analyzer.*

V1997717-2

Certificate Number

7/17/97 Res. Tri. Pk.

Course Date & Site

[Signature]
Director of Training

[Signature]
President & CEO - NITON



**ICN Worldwide
Dosimetry Service**



ICN

March 17, 1998

Quotation Number: 10640

Mecklenburg County Health Dept.
Attn: Jim Ericson
700 N. Tryon Street
Suite 298
Charlotte, NC 28202

Telephone : (704) 336-5546

Dear Mr. Ericson:

Thank you for your interest in our dosimetry service. Per your request, we are pleased to quote as follows for approximately 4 monthly and quarterly film and ring badges:

<u>Quantity</u>	<u>Description</u>	<u>Unit Price (\$)</u>
2	Quarterly, ring badges	14.73
2	Monthly, whole body film badges	8.10
	Set-up charge	1.25
	Non-returned rings	20.00

This quotation will be valid for 60 days and the quoted prices will remain firm for one year after the start of the service.

With our sub-accounting option, you have badges sent to you packed separately for each department or sent directly to the department. We can send reports to you with a copy to each department.

To switch to our service is very easy and we do the work that is involved at no charge. Simply send us the packing list from your current vendor which should include your participant's names, birth dates, Social Security numbers and badge types. We will set up your new account with this information and subdivide by departments. When you receive your final radiation report from your current vendor, you would need to send us a copy so that we can add the life time totals to your participant's.

Please note that all other terms and conditions listed on the attached price list apply, unless they are specifically excluded in this quotation. Delivery of your first shipment is 60 days from confirmation of the award of the contract to ICN.

I hope this information assists you in evaluating our service.

Sincerely,
ICN Dosimetry Service
Div. of ICN Biomedicals, Inc.

Wendi Pugh

Wendi Pugh
Quotations Coordinator

Correspondence: P.O. Box 16236 Irvine, CA 92713 Shipping Address: 3300 Hyland Avenue Costa Mesa, CA 92626

<http://www.dosimetry.com> e-mail: dosimetry@icnpharm.com

Toll Free: 800-251-3331 Worldwide: 1-714-545-0160 ext 6025 Fax: 1-714-668-3199

ATTACHMENT 3

National Institute
of Standards and Technology



National Voluntary
Laboratory Accreditation Program

ISO/IEC GUIDE 25:1990
ISO 9002:1987

Scope of Accreditation



Revised Scope 10/27/1997

IONIZING RADIATION DOSIMETRY

Page: 1 of 2

NVLAP LAB CODE 100555-0

ICN DOSIMETRY SERVICE, DIV. OF ICN BIOMEDICALS, INC.

3300 Hyland Ave., ICN Plaza

Costa Mesa, CA 92626

Ms. Sandra Nemecek

Phone: 714-545-0100 x2297 Fax: 714-668-3149

Scope of Accreditation:

This facility has been evaluated and deemed competent to process the radiation dosimeters listed below through employing a Panasonic automatic reader model UD710A and a manual reader model UD702, and the Harshaw model 3500 manual reader for TLD processing. The MacBeth TD932 densitometer for film processing.

This facility is accredited to process the following dosimeters by virtue of actual demonstration of compliance with ANSI HPS N13.11-1993 through testing.

Panasonic TLD model ICN UD-802 with a model UD-854 or UD-874 hanger for ANSI-N13.11 categories I, II, IIIA, IV, VC, VI, VII, VIII.

ICN model T2 (Kodak type II film) for ANSI-N13.11 categories I, II, IIIA, IV, VA, VI, VII.

ICN Film Badge (Kodak Type 3) for ANSI-N13.11 categories I, II, IIIA, IV, VA, VI, VII.

Panasonic TLD model UD-802 with CR39 in a model UD-874 hanger for ANSI-N13.11 category VIII.

ICN model T2 (Kodak type II film with CR39) for ANSI-N13.11 category VIII.

June 30, 1998

Effective through

For the National Institute of Standards and Technology

National Institute
of Standards and Technology



National Voluntary
Laboratory Accreditation Program

ISO/IEC GUIDE 25:1990
ISO 9002:1987

Scope of Accreditation



Revised Scope 10/27/1997

Page: 2 of 2

IONIZING RADIATION DOSIMETRY

NVLAP LAB CODE 100555-0

ICN DOSIMETRY SERVICE, DIV. OF ICN BIOMEDICALS, INC.

ICN Remtrack (Harshaw) TLD model 100 enclosed in a laminated polyethylene material holder for ANSI N13.11 category II and IV.

HLD-100 for ANSI-N13.11 categories I, II, IIIA, IV, V, VA, VI, VII.

HLD-760 for ANSI-N13.11 categories I, II, IIIA, IV, VC, VI, VII, VIII.

This facility has been accredited to process the extremity dosimeters listed below by virtue of actual demonstration of compliance with ANSI-N13.32-1995 and NIST Handbook 150-4, Page 14, Table 2 categories.

HLD-100 (Wrist), based on technical equivalence, for categories I, II, IIIA, IIIB, IV, VA, VI, VII.

HLD-760 (Wrist), based on technical equivalence, for categories I, II, IIIA, IIIB, IV, VA, VI, VII.

HLD-100 (Ring), based on testing, for categories I, II, IIIA, IV, VA, VB, and VD.

HLD-100 1C (Ring), based on technical equivalence, for categories I, II, IIIA, IV, VA, VB, VD.

June 30, 1998

Effective through:

For the National Institute of Standards and Technology

Environmental Education Associates, Inc.

United States Department of Commerce
National Institute of Standards and Technology

NVLAP[®]



ISO/IEC GUIDE 25:1990
ISO 9002:1987

Certificate of Accreditation

ICN DOSIMETRY SERVICE, DIV. OF ICN BIOMEDICALS, INC.
COSTA MESA, CA

is recognized under the National Voluntary Laboratory Accreditation Program for satisfactory compliance with criteria established in Title 15, Part 285 Code of Federal Regulations. These criteria encompass the requirements of ISO/IEC Guide 25 and the relevant requirements of ISO 9002 (ANSI/ASQC Q92-1987) as suppliers of calibration or test results. Accreditation is awarded for specific services, listed on the Scope of Accreditation for:

IONIZING RADIATION DOSIMETRY

June 30, 1998

Effective through

For the National Institute of Standards and Technology
NVLAP Lab Code: 100555-0

ICN Dosimetry Service

Terms & Conditions

Renewal of Service Service is automatically renewed, without further notice, for successive like periods unless written notification is received at ICN 40 days before the start of a renewal service period. Cancellation includes the termination of all ancillary services, including on-time services, as of the effective date of cancellation. Cancellation before the end of a minimum order period will be rebilled at short term rates. All badge holders must be promptly returned to avoid additional charges.

Minimum Invoice: \$50

Short-Term Charge Add 20% to unit price per shipments for contracts 2-11 months.

Additions to Existing Account \$1.25 for each new wearer set-up during service period. No charge for deletions.

Control Dosimeter A control dosimeter is supplied at no charge with each shipment for the purpose of measuring radiation exposure while the dosimeter shipment is in transit and/or storage. The control dosimeter must be returned with dosimeters of the same frequency period.

Holders All holders remain the property of ICN. Requests for additional holders or holders that must be replaced due to loss or damage will be subject to a replacement fee. In addition, the holders marked with an asterisk (*) are available for purchase and need not be returned.

Film Holder	\$ 2.00
TLD 100 Holder	\$ 2.00
TLD 760 Holder	\$ 2.00
TLD Environmental Holder	\$ 3.00
TLD Chambeil	\$ 8.00
TLD 802 Holder	\$ 2.00
Rings	\$ 2.00
*SnapPak: 1 use pouch	\$ 0.75
*FlexPak: 1 use pouch	\$ 0.75
*Snap On clip: with plastic loop	\$ 0.35
*Velcro wrist band	\$ 2.00
*Velcro 50 inch belt	\$ 7.00
*Area hook	\$ 2.00

Non-Returned/Damaged Badges ALL badges remain the property of ICN and must be returned at the end of each exchange period. A dosimeter (including controls) not returned 45 days after the end of the wear period, or received in damaged condition will incur a replacement charge for each dosimeter:

TLD 100	\$ 18.00	Flexring	\$ 20.00
TLD 760	\$ 20.00	MeasRing	\$ 20.00
TLD Environmental	\$ 25.00	Hard Ring	\$ 20.00
TLD 802	\$ 20.00	Irms	nc
814 Environmental	\$ 25.00	CR-D)	nc

Payment Terms: Prices are subject to change with 30 days notice. Service is billed in advance for a full minimum period for all accounts. Any other billing arrangements must be agreed to in writing by ICN. Adjustments for additions/deletions during the billing period will be reflected on the next billing period. Purchase orders are accepted only on the terms and conditions stated herein, unless specifically agreed to in writing by an authorized representative of ICN Dosimetry. 1% monthly finance charge (18% per annum) may be added to all accounts 30 days past due. Payment is due upon receipt of invoice.

"We hereby certify that these goods were produced in compliance with all applicable requirements of sections 6, 7 and 12 of the Fair Labor Act, as amended, and of regulations and orders of the U.S. Dept. of Labor issued under section 14 thereof. We certify that these goods are of U.S. origin.

Additional Service Information

Exchange Periods	Annual Shipments
Quarterly	4
Monthly	12
Bi-Weekly	26
Weekly	52
Short Term	2-11
One-Time	1

Reshipments Reshipments at customer's request will incur additional charges of the unit price plus the special handling charge. Requests for express shipment will be billed at \$25.00/package unless customer supplies a billing number to send package prepaid.

Special Handling A charge of \$2.50 will be made for each package that must be mailed separately from the regularly scheduled shipments. Requests for express shipment will be billed at \$25.00/package unless customer supplies a billing number to send package prepaid.

Departmental (Location) Separation Accounts separated into groups for mailing and reporting:

- A. In one package to one site address \$1.50/department/shipment
B. In separate packages to various site addresses \$2.50/department/shipment

Emergency Processing With prior notification, ICN will respond with the results by fax or email within a 24-hour period from the time of receipt at ICN. There is a charge per occurrence plus a charge for each badge to be processed as an emergency. Requests must be accompanied by a signed authorization. ICN must receive prior notification that a request for emergency processing is being shipped to ICN.

	Charge Per occurrence	Per badge
Monday-Friday, excluding Holidays 8AM PST to 4:30PM PST	\$ 75	4
4:30PM PST to 8AM PST	\$ 150	
Saturday/Sunday, excluding Holidays	\$ 300	5
Holidays	\$ 900	\$5

Audits All requests for on-site audits are by specific written agreement with ICN. A 30-day notice is required, and the audit will be by mutually agreed upon dates. All audits will be pre-billed at a rate of \$2,000 per work day for each full or partial day of the audit. Work days for audits are Tuesday through Thursday, excluding holidays, 9AM PST to 4PM PST.

Additional Reports

Duplicate of current reports

Sent to same address	\$ 0.50 per page
Sent to different address	\$ 0.75 per page

Copies of previously issued reports

Less than 1 year old (prepaid)	
Base Charge	\$ 35.00 per request
Copies	\$ 0.50 per page
Greater than 1 year old (prepaid)	
Issue Charge	\$ 100.00 per request
Copies	\$ 0.50 per page

Form 4/Form 5 Equivalent

1 ply	\$ 1.25 per page
2 ply	\$ 1.50 per page

Adjusted Dose Report

Requests for re-analysis of reported doses \$ 50.00 per report

Report or Packing List On Disk or E-mail \$ 25.00 per file

Services not listed will be quoted upon written request.



ICN Worldwide Dosimetry Service
ICN Plaza, 3300 Hyland Avenue, Costa Mesa, CA 92626
U.S./Canada: (909) 251-3331 • Worldwide: (714) 545-0100 x6925
http://www.dosimetry.com • e-mail: dosimetry@icnpharm.com
Environmental Education Associates, Inc.

Leak/Wipe Test Instructions

1. Remove swab from zip-lock bag.
2. Dampen swab and shake off excess water.
3. Wipe the swab over all seams, screws, and the shutter window (shutter closed). (See diagram below.)
4. Replace the swab in the zip-lock bag.
5. Fill out the forms and return the test to the test provider for analysis.

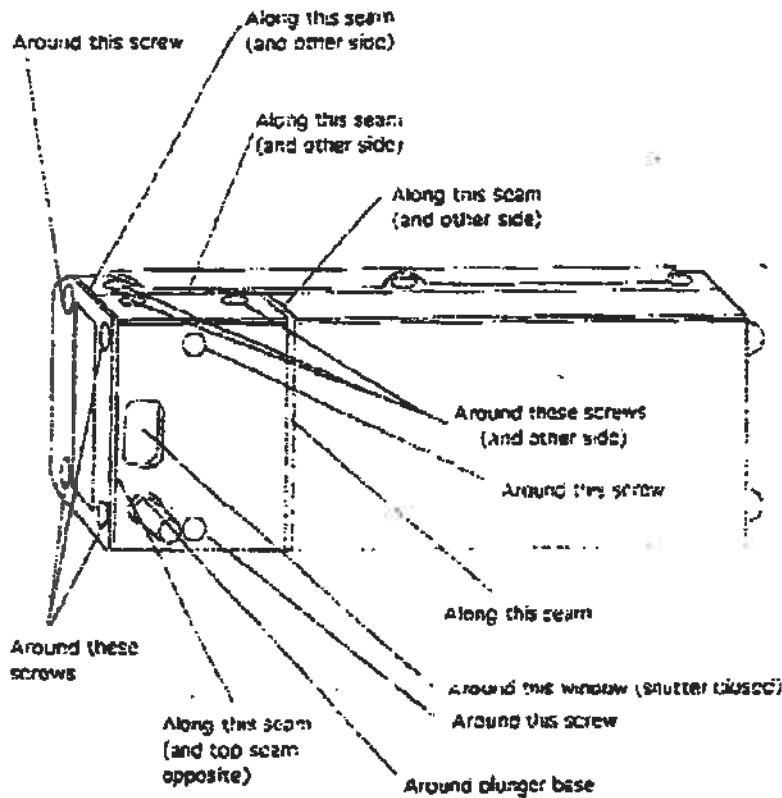

ATTACHMENT 4

NITON[®] corporation

ENVIRONMENTAL RESEARCH AND MEASUREMENT PRODUCTS FOR RADON AND LEAD

Have you done a Leak Test lately?

As the owner of an XL Spectrum Analyzer, you are probably required by your license, based on your state's radioactive licensing regulations, to do a leak test every six (6) months.

Right now, according to our records, you are either overdue, or must do it within the next month.

If you have already done it, Congratulations! You are a conscientious XL owner and we applaud you. If you fall in one of the other categories, please make plans to do a Leak Test right away.

The kits are available from many labs (probably one in your area). Here are some of the ones we use:

Valley Safety Services 330 Old Enfield Road, Belchertown, MA 01007	Tel: 413/323-9571	\$25/Kit
Applied Health Physics 2986 Industrial Blvd., Bethel Park, PA 15102	Tel: 412/835-9555	\$30/Kit
Stan A. Huber Consultants 200 N. Cedar Road, New Lenox, IL 60451	Tel: 1-800-353-0468	\$18/Kit

NITON
← ULSCA

Call one of these telephone numbers TODAY, give them a credit card and they will forward a leak test kit, with instructions. It's a cinch: a Q-tip dipped in a detergent solution is wiped around the outside of the XL. Put the Q-tip back in its bag and send it off to the lab. A few days later, you will receive a report... and be "legal" again.

If there is any radioactivity noted over the allowed limit, please call the NITON Radiation Safety Officer immediately at 1-800-875-1578. You will be advised of the correct procedure for returning the source to NITON/source supplier for proper disposal.

IMPORTANT: Your unit must have a copy of a current wipe test shipped in the case with the XL at all times. If your XL arrives at our Rhode Island facility for servicing or re-sourcing without one, we'll have to do the wipe test for you. Charge: \$75. It will also mean 4 to 5 days more that we must keep your XL, because, under our own licensing, we can't ship out an instrument without a current wipe test.

P.O. Box 368 • 74 Loomis Street • Bedford, MA 01730-0368 • 617-275-9275 • 800-875-1578

Radiation Safety

It is required under our license and yours that a leak test be done every 6 months. Leak test kits, with full instructions, are available from several sources. They will remind you to retest each 6 months. Please follow the test kit instructions and promptly mail the test sample to the laboratory. Sources for leak testing include:

Applied Health Physics
2986 Industrial Boulevard
Bethel Park, PA 15102
Tel: (412) 835-9555

Stan A. Huber Consultants
200 North Cedar Road
New Lenox, IL 60451
Tel: (800) 383-0468

Valley Safety Services
330 Old Enfield Road
Belchertown, MA 01007
Tel: (413) 323-9571

How to monitor your safety:

There is virtually no measurable radiation from an XL when its shutter is closed. The maximum dosage to which you are exposed when properly operating the XL is 0.1 mR/hr on the fingers of the hand holding the XL with the shutter open. The dosage you would receive on the fingers holding the shutter open for 8 hours a day, 200 days a year is 160 mR. This "worst case" is but a tiny fraction of the allowable exposure levels.

NITON strongly recommends that you wear a dosimeter to assure yourself that your exposure is minimal. NITON has done everything in its power to protect you. Do your part. Use a dosimeter.

The dosimeter is usually a badge that is worn on your body. These badges are available from many companies. One company selling dosimeters is:

Landauer, Inc.
2 Science Road
Glenwood, IL 60425-9979
Tel: (708) 755-7000

Each month, the company will send you a new badge, so you can send yours in for analysis to find out if undue exposure occurred. If, at any time, you find measurable exposure, call NITON immediately.

**ICN Worldwide
Dosimetry Service**



ICN

March 19, 1998

Quotation Number: 10645

Mecklenburg County Health Department
Attn: Dennis Salmen
700 N. Tryon Street
Suite 298
Charlotte, NC 28202

Telephone : (704) 336-5546

Dear Mr. Salmen:

Thank you for your interest in our dosimetry service. Per your request, we are pleased to quote as follows for approximately 1 semi-annual leak test kit:

<u>Quantity</u>	<u>Description</u>	<u>Unit Price (\$)</u>
1	Semi-annual leak test kit	37.50
	Set-up charge	1.25

This quotation will be valid for 60 days and the quoted prices will remain firm for one year after the start of the service.

Please note that all other terms and conditions listed on the attached price list apply, unless they are specifically excluded in this quotation. Delivery of your first shipment is 60 days from confirmation of the award of the contract to ICN.

I hope this information assists you in evaluating our service.

Sincerely,
ICN Dosimetry Service
Div. of ICN Biomedicals, Inc.

Wendi Pugh

Wendi Pugh
Quotations Coordinator

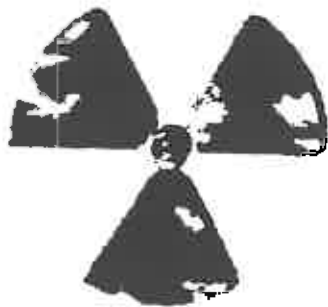

Leak Test Kits Price List

Effective April 1, 1997

ICN's sealed source leak kit contains complete instructions and all materials necessary to do each test. Simply perform the test, complete the data sheet and return the kit to us. ICN will analyze your test using instrumentation capable of detecting any alpha, beta or gamma emitting radionuclide in amounts less than 0.001 microcurie. In a few days your leak test certificate will be mailed to you.

In the event of a positive result greater than 0.001 microcurie, we will call you immediately to inform you of the possibly hazardous situation. Additional health physics services can be provided if necessary.

Analysis Service

QTY	Leak Test Kit
1-50	37.50

ICN Leak Test Kit

Kit may be ordered as needed or on a continuous service basis. If continuous service is requested, we will automatically send you the required number of kits every six months. Before ordering, be sure your license authorizes you to perform this test. If not, your license can easily be amended.

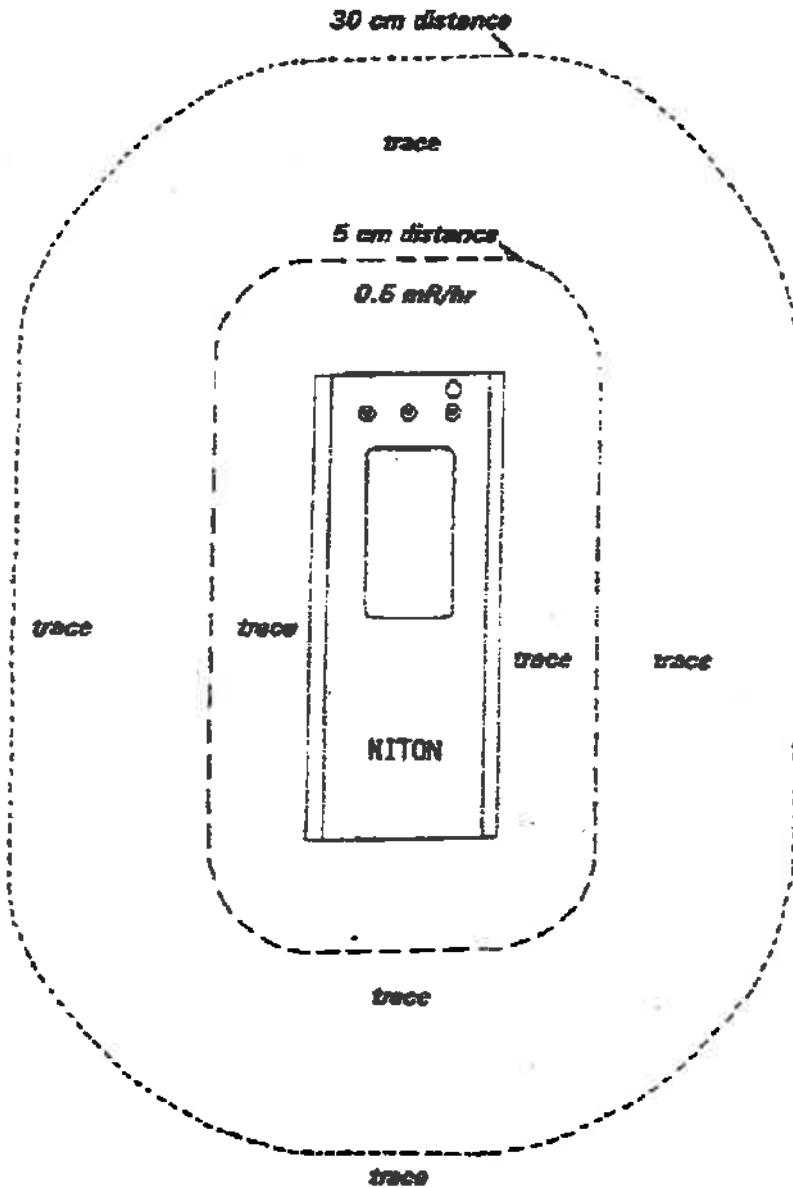

Shutter Open

*Max radioactivity on operator's hand, with shutter open: 0.05 mR/hr
Trace = <0.05 mR/hr - Not detectable above natural background levels.*

Cadmium 109 Decay Information

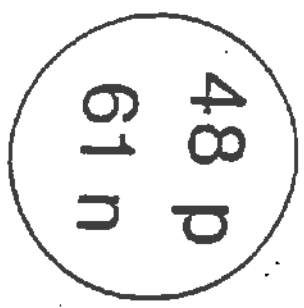

Cd-109

Electron Capture

Half-Life 462.6 days

X rays, 22-25 keV

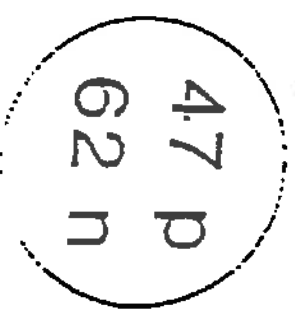

Ag-109m

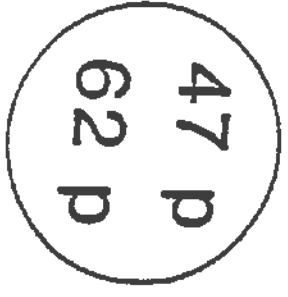

Ag-109m

Isomeric Transition

Half-Life 39.6 seconds

88.03 keV Gamma Rays

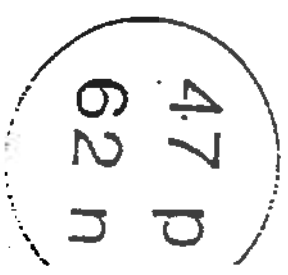

Ag-109

Stable

FETAL DOSE POLICY

On this date I voluntarily notified the Mecklenburg County Health Department, Childhood lead Poisoning Prevention Program, of my pregnancy. The estimated date of conception was _____ . This is my written statement to comply with .1610 (attached) of the regulation for Protection Against Radiation, for a "declared pregnant woman".

Signature

ATTACHMENT 7



ENVIRONMENTAL RESEARCH AND MEASUREMENT PRODUCTS FOR RADON AND LEAD

**United States Department of Transportation and
International Atomic Energy Agency
Compliance Statement**

**Lead-based Paint and
Multi-element Spectrum Analyzers**

The XL Lead Detector and the 700Series Multi-element Spectrum Analyzers conform to the conditions and limitations specified in 49 CFR 173.422 for excepted radioactive material, instruments and articles, N.O.S. UN 2910.

The radiation level at any point on the external surface of this package does not exceed 0.5 millirem per hour.

No other labels are required or authorized.

This package contains no more than 50 mCi cadmium-109 source in a plated solid, sealed source installed in an x-ray fluorescence analyzer.

This instrument contains an accelerator-produced source.

For further information please contact NITON Corporation

*This compliance statement should accompany
this package at all times.*

P.O. Box 365 • 74 Loomis Street • Bedford, MA 01730-0368 • 617-275-9275 • 800-875-1578

NITON Corporation FAX

Date: 3/17/98

Number of pages including cover sheet 10

TO:

Dennis Salmer
Mecklenburg County
Health Dept.

From:

Nancy Sanderson
NITON Corporation
74 Loomis Street
Bedford, MA 01730

Phone: -5554

Fax: 704-336-5536

CC: _____

Fax: _____

Phone: (781) 275-9275 x308

(800) 875-1578 x308

Fax: (781) 275-1917

Remarks:

Urgent For your review Reply ASAP Please comment

AS for standard disposal of the radioactive source, NITON takes care of that when the instrument comes in for re-sourcing.

SOURCE INVENTORY SHEET

Source Identification No. _____

Manufacturer:

Prepared

Physical Form:

Isotope:

Activity:

Use:

Storage Location:

Inventory

Leak Test

Date Due:

Due:

Initials:

Date:

Results:

Initials:

Date Entered Into Inventory:

Date of Disposal:

Comments:

(FORM "A")

NITON INSTRUMENT ACCOUNTABILITY RECORD

Device: Model No. _____

S/N No. _____

Source: S/N No. _____ Activity _____

S/N No. _____ Activity _____

The "Notes" column is to be used to record the shipping dates and status of device when shipped to manufacturer for maintenance.

(Print or Write Legibly)

Licensed User Name	Location or Destination	Date	Notes (See Instructions Above)
Check-Out _____	_____	_____	_____
Check-In _____	Secured in Storage	_____	_____
Check-Out _____	_____	_____	_____
Check-In _____	Secured in Storage	_____	_____
Check-Out _____	_____	_____	_____
Check-In _____	Secured in Storage	_____	_____
Check-Out _____	_____	_____	_____
Check-In _____	Secured in Storage	_____	_____
Check-Out _____	_____	_____	_____
Check-In _____	Secured in Storage	_____	_____
Check-Out _____	_____	_____	_____
Check-In _____	Secured in Storage	_____	_____

(FORM "B")

2nd Floor - HAL MARSHALL BLDG. (700 N. TEXAS)

EMERGENCY EXIT

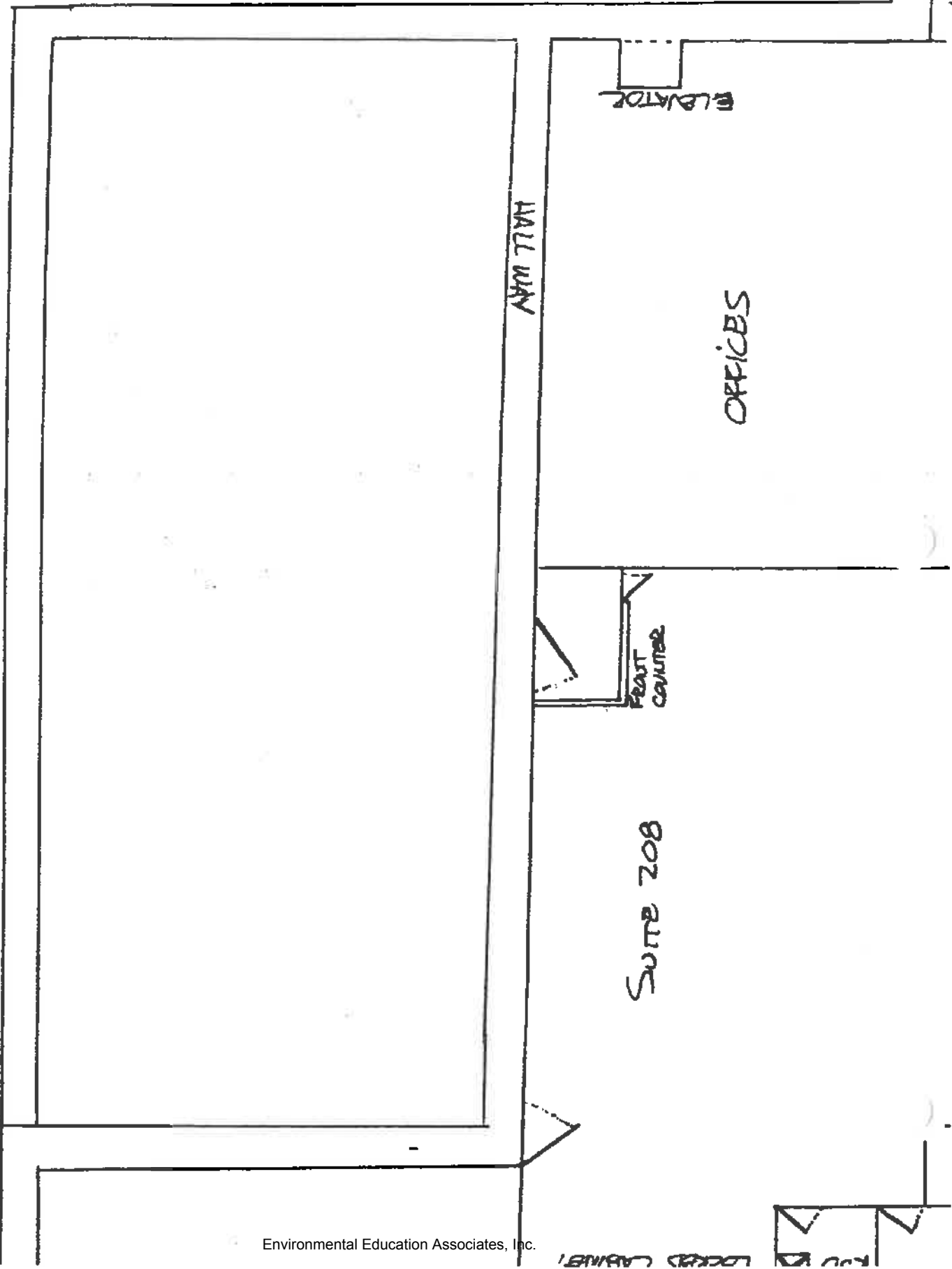



CHAPTER 7

LEAD-BASED PAINT TESTING OPERATIONS

Objective	7-3
Learning Tasks	7-4
Background of the Inspection Protocol	7-5
Responsibilities	7-6
Preparing for the Inspection	7-7
Designing the Inspection Plan	7-9
Terms and Definitions	7-11
Types of Housing	7-14
Inspection Steps	7-23
Testing in Single-Family Housing	7-24
Inventory and Selection of Painted Surfaces	7-25
Calibration Checks	7-31
Number of Readings on Each Testing Combination	7-32
Selection of Test Locations	7-33
Testing on Nonflat Surfaces	7-34
Abbreviation of Testing	7-35
Substrate Correction	7-36
Inspections in Multifamily Housing	7-41
Common Areas	7-41
Computing Sample Size	7-43

continued

Inspecting for Lead-based Paint

Selecting the Specific Units	7-5
Testing Combinations	7-5
Common Area Testing	7-54
Substrate Correction in Multifamily Housing	7-55
Classification of Components	7-56
Unsampled Housing Units	7-61
Quality Assurance and Quality Control Measures	7-63
Preparation of Laboratory (Paint Chip) Samples	7-67
Laboratory Submittal	7-74
Review of Previous Paint Testing Results	7-75
Recordkeeping	7-78
For More Information	7-79
Appendix A	7



Lead-based Paint Testing Operations

Objective

The objective of this chapter is to provide a step-by-step discussion of how to do a lead-based paint inspection in both multi- and single-family housing, including:

- selecting surfaces to test;
- understanding the technology required;
- choosing the applicable analytical method(s);
- evaluating the results;
- documenting the inspection with proper record keeping; and
- providing a complete, readable report.



Learning Tasks

After completing this chapter, inspectors should be able to:

- explain their responsibilities and those of property owners and managers;
- specify the disclosure obligation of landlords and sellers (24 CFR Part 35 and 40 CFR Part 745);
- describe the standards and protocol(s) applicable to lead-based paint inspections;
- understand the components used in building construction, their potential effect on XRF readings, and the proper terms for labeling samples;
- within any house or child-occupied facility, identify all testing combinations which should be tested;
- using a floor plan of a dwelling, demonstrate a systematic way to document the testing conducted;
- determine whether test results are positive, negative, or inconclusive for LBP and keep detailed and accurate records of the inspection;
- describe how and when to conduct paint-chip sampling; and
- list at least three differences between inspections in multifamily and single-family housing.

For an inspector, this section is important because:

- it describes the core of the inspector's job;
- it provides a framework to analyze and keep records on the lead-based paint in a multifamily housing development or single-family home.



Lead-based Paint Testing Operations

Background of the Inspection Protocol

In 1990 HUD issued the first comprehensive document addressing lead-based paint in housing. This document, *Lead-based Paint: Interim Guidelines for Hazard Identification and Abatement in Public and Indian Housing* (commonly referred to as the *Interim Guidelines*) established criteria for conducting lead-based paint inspections in public and Indian housing.

The *Interim Guidelines* described how to conduct a lead-based paint inspection. The 1976 and 1987 amendments to the Lead-based Paint Poisoning Prevention Act initially established the definition of lead-based paint. The statute and regulations described the use of the XRF analyzer or laboratory analysis and specified a reading of 1.0 mg/cm² and 0.5 percent by weight (5,000 parts per million) respectively as the level that required abatement in public and Indian family housing developments.

When Congress passed Title X in 1992, it mandated that HUD revise the *Interim Guidelines* to include information addressing lead hazards in all types of federally-assisted housing. The *1995 Guidelines for the Evaluation and Control of Lead-based Paint Hazards in Housing* included a revised protocol for conducting lead-based paint inspections (Chapter 7). In 1997, after two years of use, this protocol was further refined and is detailed here.

LBPPPA defined lead-based paint as 1.0 mg/cm² or 0.5 percent by weight.

This chapter is largely based on the 1997 version of Chapter 7 of the HUD Guidelines.



Responsibilities

Various groups and governmental bodies have responsibilities for conducting, evaluating the quality of, or developing a hazard control strategy based upon lead-based paint testing. These groups include the following:

- state, Indian tribe, and local governments;
- the U.S. Department of Housing and Urban Development (HUD);
- the U.S. Environmental Protection Agency (EPA);
- housing authorities;
- homeowners and landlords; and
- lead-based paint inspectors, risk assessors, and hazard control contractors.

This chapter will concentrate on the roles and responsibilities of lead-based paint inspectors; however, the responsibilities of the other groups will also be briefly summarized. Individual states, Indian tribes, and local governments may set requirements for lead-based paint testing that are different than the protocol described in this curriculum. Therefore, an inspector must be aware of the special regulations which apply to any state, Indian nation, or local government where he/she may work.

Housing Authorities, which are local agencies receiving their funding from HUD, were required to perform lead-based paint testing in their pre-1978 family public housing developments by the Lead-based Paint Poisoning Prevention Act. They must act very quickly in structures in which there is a report of children who show a high level of lead in their blood when given a standard blood test by their physician or clinic. This situation is called "Elevated Blood Lead (EBL)." In such a case, either the units in which children with an EBL reside must be tested and abated promptly, or the children must be moved to lead-safe units.

The HUD regulations affecting federally-owned and assisted housing coined another term addressing children who are lead-poisoned: environmental intervention blood lead level (EIBLL) (24 CFR Part 35). This term specifically addresses children whose blood lead levels trigger an environmental investigation to determine the cause of the poisoning.

This protocol is *not* designed to be used to respond to a child who has been diagnosed with an EBL or EIBLL, although elements of this and the risk assessment protocol may be used for EBL investigations. EBL investigations are generally the responsibility of the public health department of the city, county, or state in which the child resides. If an inspector receives a request for an LBP inspection from a parent or local/state agency on behalf of a child with an EBL, it is very important that he/she contact the public health agency to coordinate their activities with them. *Only a licensed/certified risk assessor can conduct either a risk assessment or an EBL investigation.*

This inspection protocol is not designed to respond to a child with an EBL.

Only a certified or licensed risk assessor may conduct an EBL investigation.



Lead-based Paint Testing Operations

Preparing for the Inspection

Before a lead-based paint inspector begins an inspection, a pre-inspection conference should be held between the inspector and the client to discuss

- what a lead-based paint inspection does and does not include;
- why the client wants an inspection;
- specific information on the unit type and construction, including any renovation or remodeling that occurred after 1977;
- how long it may take to conduct the inspection;
- the option of abbreviating the testing (see page 7-34);
- the possible need for destructive sampling (make sure they understand why an inspector may need to collect paint chip samples);

Paint chip sample collection may require

- obtaining materials for recoating the sampled surfaces (if desired)
- an estimation of number and cost of paint chip samples
- additional time required to obtain results of paint chip samples
- obtaining access to all the units to be tested;
- preference for units to be unoccupied during testing (especially by children and pregnant women);
- timing and schedule of the inspection and final report;
- federal requirements to disclose the results of the inspection to tenants or buyers;
- quality assurance measures available to the client;
- provision of an inspector escort (for tenant-occupied housing); and
- security issues.

The first part of this section is devoted to developing the sampling or testing plan. This chapter focuses on developing a plan for testing both single-family housing and multifamily developments. However, many of the principles explained in this chapter could also be applied to an inspection in other types of buildings, such as child-care facilities.

Special terms and conditions

Terms and conditions is basically a phrase that describes the contract. It applies to the contractual arrangements between the client and the inspection firm and details what the client has asked be done. This section should include the scope of work, schedule, cost estimate, and payment terms. This is a confidential contract between the client and the

Make sure the client understands what a lead-based paint inspection does and does not include.

Emphasize the importance of access when conducting inspections in tenant-occupied housing.

Terms and conditions regarding the inspection must be spelled out in the contract between the inspector and the client.



Inspecting for Lead-based Paint

inspector and except for restating the scope of work, specific information outlined in the contract should not be included in the final report.

Example language could include:

“Client has requested that a lead-based paint inspection be performed in order to [indicate the client’s reason for having the inspection conducted].”

There are many reasons why a client may choose to have a lead-based paint inspection conducted, including, but not limited to:

- legal requirement;
- requirement of a financial institution;
- component of a pre-purchase inspection of a dwelling;
- parental concern about lead or lead hazards;
- supplement to an EBL investigation conducted by the state or county health department; and
- component of planned renovations.

Knowing the reason(s) an inspection has been requested will assist the inspector to provide a report that best meets the client’s needs and complies with regulatory requirements (if applicable). Be sure that the client understands that even though there may be no lead-based paint according to the federal definition, disturbing painted surfaces can still create a hazard to a worker or occupant (especially a child).

Another example of a special condition is if a property owner has requested lead-based paint inspections of several properties that are not contiguous, but wants the inspector to provide one report. This single report may refer to ‘the site’ but contains the results of testing of multiple properties. Therefore, a statement to that effect should be included in contract.

There are many reasons why a client may choose to have a LBP inspection conducted.



Lead-based Paint Testing Operations

Designing the Inspection Plan

An inspection in single-family housing represents the most straight forward type of lead-based paint inspection in that the entire dwelling is inspected, including any coated structures on the property (e.g., fences, garages). Therefore the planning steps involve

- scheduling the inspection;
- accessing the property and coated building components;
- determining painting histories of components;
- determining the surfaces to be tested;
- selecting a specific primary testing method (XRF analyzer or laboratory analysis);
- planning quality assurance tests;
- identifying a laboratory for paint-chip sample analysis, if applicable;
- documenting the results in a final report.

In addition to the considerations listed for single-family housing, when inspecting multifamily developments the design of an inspection involves

- randomly selecting units to be tested;
- randomly selecting common areas to be tested;
- analyzing the results to determine whether there is a pattern of lead-based paint on specific building components; and
- creating a development-wide summary of component types coated with lead-based paint.

EPA, state, and Indian tribe rules (effective 1 March 2000 in those states or Indian nations where EPA is administering the training and certification rules) require that the inspector use a “documented methodology” when performing any lead-based paint activity. The only widely available methodology for conducting lead-based paint inspections in housing is the protocol described in the 1997 version of Chapter 7 of the HUD *Guidelines*.

In order for an inspector to successfully carry out his/her responsibilities, he/she must:

- become familiar with the Federal, state, tribal, and local regulations regarding lead-based paint testing in areas where inspections will be performed;
- obtain all state, tribal, or EPA certifications and licenses that apply (including a radiation safety certification or license, if applicable);

Inspections must be conducted using a documented protocol.

An inspector must be certified or licensed to conduct inspections in target housing or child-occupied facilities.



Inspecting for Lead-based Paint

Be sure to inform the client of the owner's duties to disclose the results of the inspection.

- be thoroughly trained in the methods of testing for lead-based paint and the safe and accurate use of the XRF analyzer (this includes being able to determine when laboratory tests requiring paint samples from the dwelling are needed);
- select and notify the appropriate NLLAP-recognized laboratory and carefully follow the instructions submitting paint samples, when these samples are required;
- determine when substrate correction of XRF readings is needed;
- fully document, in a clear and direct manner, the results of the testing and the location of all samples which were taken (more information on preparing the final report is included in Chapter 13 *Data Analysis and Report Writing*);
- notify the client of the test results in a clear and easily understandable report format;
- conduct the testing in an honest and ethical manner;
- inform the client of the property owner's duties under the disclosure rule (24 CFR part 35 and 40 CFR part 745) to transmit the results of the inspection to prospective buyers or renters *before* they become obligated under a sales or lease contract.

These are very important responsibilities. In order to fulfill them, successful completion of this training course is critical. The next section discusses how to effectively carry out many of these responsibilities.



Lead-based Paint Testing Operations

Terms and Definitions

Within all professions and trades there are terms that are used routinely and must be understood in order to communicate effectively. Lead-based paint inspections are no exception. Many of the terms which will be defined in this section are defined by statute, rule, guidance, or common usage. Some of the terms are not consistent with terminology used in the construction or demolition trades. Therefore, it is important that any term used in an inspection report is clearly defined (preferably both in text and by diagram, where applicable) before a hazard control strategy is designed and implemented.

- *lead-based paint inspection*—a surface-by-surface investigation to determine the presence of lead-based paint and the provision of a report explaining the results of the investigation (informally called an *inspection*).
- *room equivalent*—an identifiable part of a residence, such as a room, house exterior, a foyer, staircase, hallway, or an exterior area (exterior areas contain items such as play areas, painted swing sets, painted sandboxes, fences, etc.).
- *building component type*—those items in the interior or exterior of housing onto which paint, stain, varnish, or shellack has been applied and that have a common substrate. Table 7-1 lists commonly encountered components on the interior and the exterior of housing. (See also Figures 7-1 through 7-7.)
- *substrate*—the material underneath the paint. Many substrates exist, but the HUD *Guidelines* recommend classifying substrates into one of six substrate types:
 - brick
 - concrete
 - drywall
 - metal
 - plaster
 - wood.
- *testing combination*—unique combination of room equivalent, building component type, and substrate.
- *test location*—a specific area on a testing combination where either an XRF reading or a paint-chip sample will be taken.

It is the inspector's job to test a surface in the interior of each dwelling unit, that is representative of each type of painted, stained, shellacked, or varnished *testing combination* in every *room equivalent*.

It is important that industry terms used in an inspection report are clearly defined.

The *Guidelines* recommend classifying substrates into one of six substrate types.



Certain building components that are adjacent to each other and not likely to have different painting histories can be grouped together into a single-testing combination. *Since exterior paints are more likely to contain high levels of lead, never group interior and exterior components together!* Some examples of these groupings are listed below.

Components which can be combined as a single testing combination*

- **window systems**
 - testing combination 1: casings, stops, jambs and aprons
 - testing combination 2: interior window muntins and window sashes
 - testing combination 3: exterior window muntins and window sashes
- **door systems**
 - testing combination 1: door jambs, stops, transoms, casings and other door frame parts
 - testing combination 2: door stiles, rails, panels, muntins and other door parts
- **trim** baseboards and associated trim (such as quarter-round or shoe molding)
- **trim** painted electrical sockets, switches or plates can be grouped with walls

* The architectural terms are illustrated in Figures 7-1 through 7-7 and defined in the Glossary (Chapter 14).

Previous federal and some local lead-based paint regulations required the abatement of lead-based paint only up to five feet. Therefore, those component types that are below or extend below that threshold (e.g., door casing, window sills, casings, and aprons) may not be coated with lead-based paint, while the portion that extends above five feet is coated with lead-based paint. Inspectors should attempt to determine what regulations may have applied to a specific locality and if any previous limited abatement activity has occurred in the dwelling and modify their testing practices accordingly.

Certain adjacent building components can be grouped together if they have the same painting history.

Remember, some components were abated only up to five feet!



Lead-based Paint Testing Operations

Table 7-1. Examples of Interior and Exterior Components

Commonly encountered interior painted components that should be tested include:

air conditioners	floors
balustrades	handrails
baseboards	jamb
bathroom vanities	newel posts
beams	other heating units
built-in cabinets	radiators
ceilings	railing caps
chair rails	shelf supports
columns	shelves
counter tops	stair stringers
crown molding	stair treads and risers
doorjamb and trim	stools and aprons
doors	walls
electrical fixtures	window sashes
fireplaces	

Exterior painted components that should be tested include:

air conditioners	handrails
balustrades	lattice work
bulkheads	mailboxes
ceilings	painted roofing
chimneys	railing caps
columns	rake boards
cornerboards	sashes
door trim	siding
doors	soffits
fascias	stair risers and treads
flashing	stair stringers
floors	window casings
gutters and downspouts	window sashes
joists	

Other exterior painted components include:

fences
lampposts
laundry line posts
storage sheds
swingsets and other play equipment

Note: This list is not necessarily complete; other painted components should also be tested if encountered.

Never group interior and exterior components together.



LBP inspections may be done differently in single-versus multifamily housing

Types of Housing

For purposes of lead-based paint inspections, housing may be divided into two types:

- single-family, and
- multifamily.

Multifamily housing is traditionally defined as housing that contains more than one dwelling unit per location. However, for purposes of a lead-based paint inspection only, multifamily housing is defined as any group of units that are similar in construction from unit to unit with:

- 21 or more units if any were built before 1960 or are of unknown age, or
- 10 or more units if they were all built from 1960 to 1977.

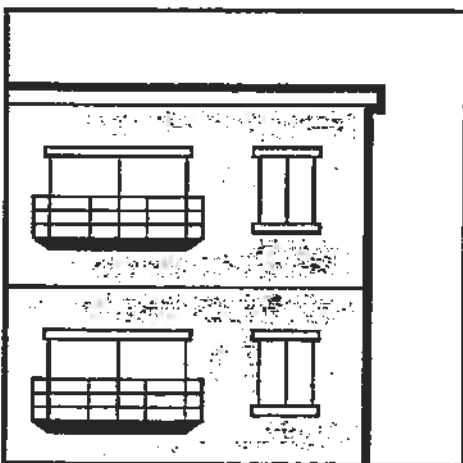

Developments with fewer units should be treated as single-family housing.

Multifamily housing can consist of groups of multiple-story apartment buildings or multiple low-rise buildings that are managed together. The units in such buildings are most often of similar or identical construction, and are subject to a common maintenance policy, including initial painting history. Thus, it is appropriate to test such buildings based on a random sample

of dwelling units (taking care that different buildings with different construction and painting history are *not* lumped together). The benefits of random sampling include:

- reducing the time and cost associated with testing;
- making it possible to reach rational decisions for large complexes without testing every unit.

As the size of the development decreases, a relatively higher percentage of dwellings must be tested in a random sample to preserve confidence in the final results.

Lead-based paint inspections in single-family housing present a challenge because each dwelling has its own unique construction and painting history. Therefore, each single-family dwelling must be tested

Single-family housing has unique construction and painting histories.

Lead-based Paint Testing Operations



separately. Test results for one single-family dwelling cannot be reliably applied to other dwellings, unless it can be shown that each has a common construction, painting, and maintenance history. Additionally, condominium and cooperative housing complexes may have a common initial construction history, but the painting history of each unit will vary since each has different owners and unique painting histories. Therefore, they should be treated like single-family housing.



Figure 7-1
Diagram of Building Components

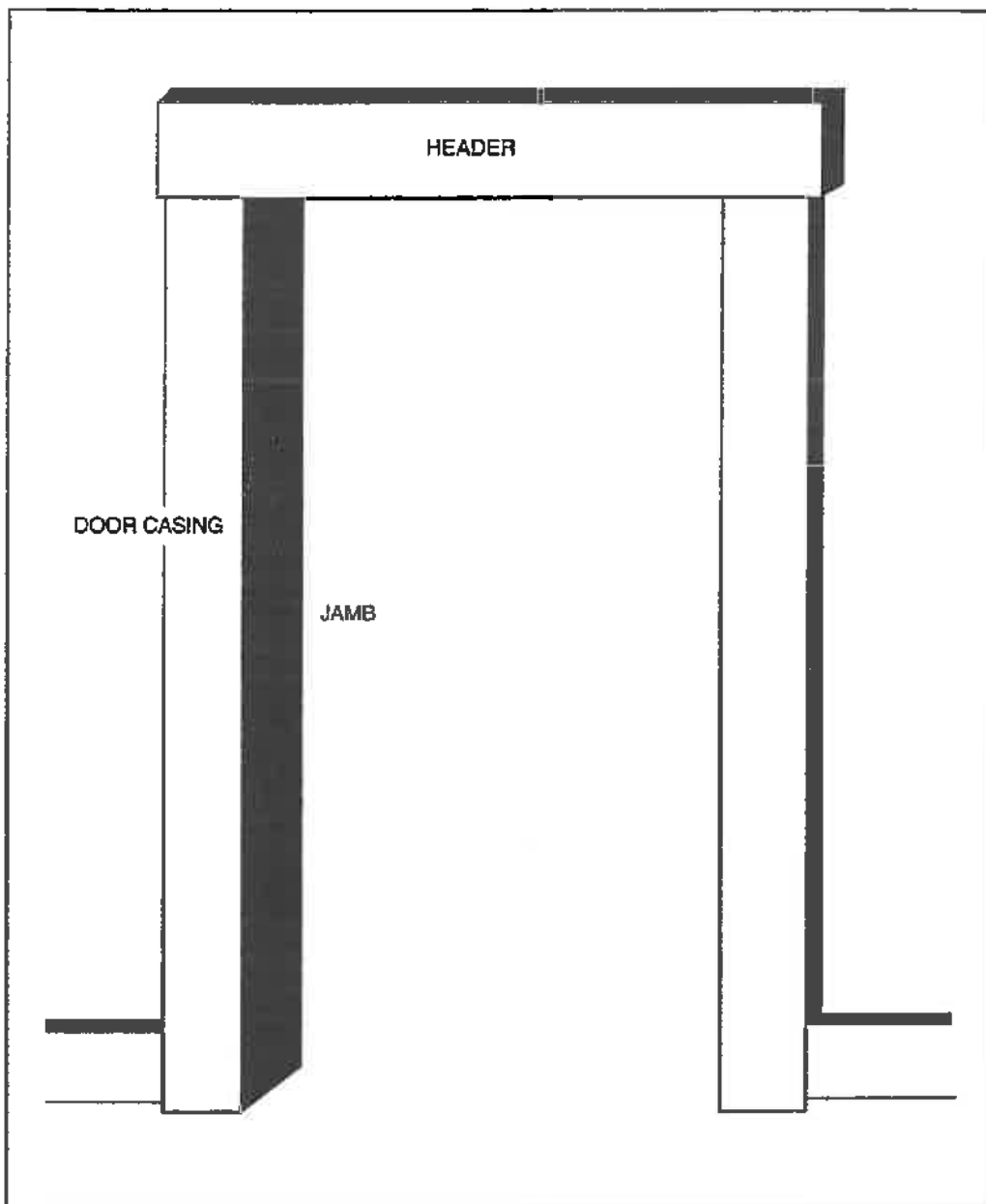
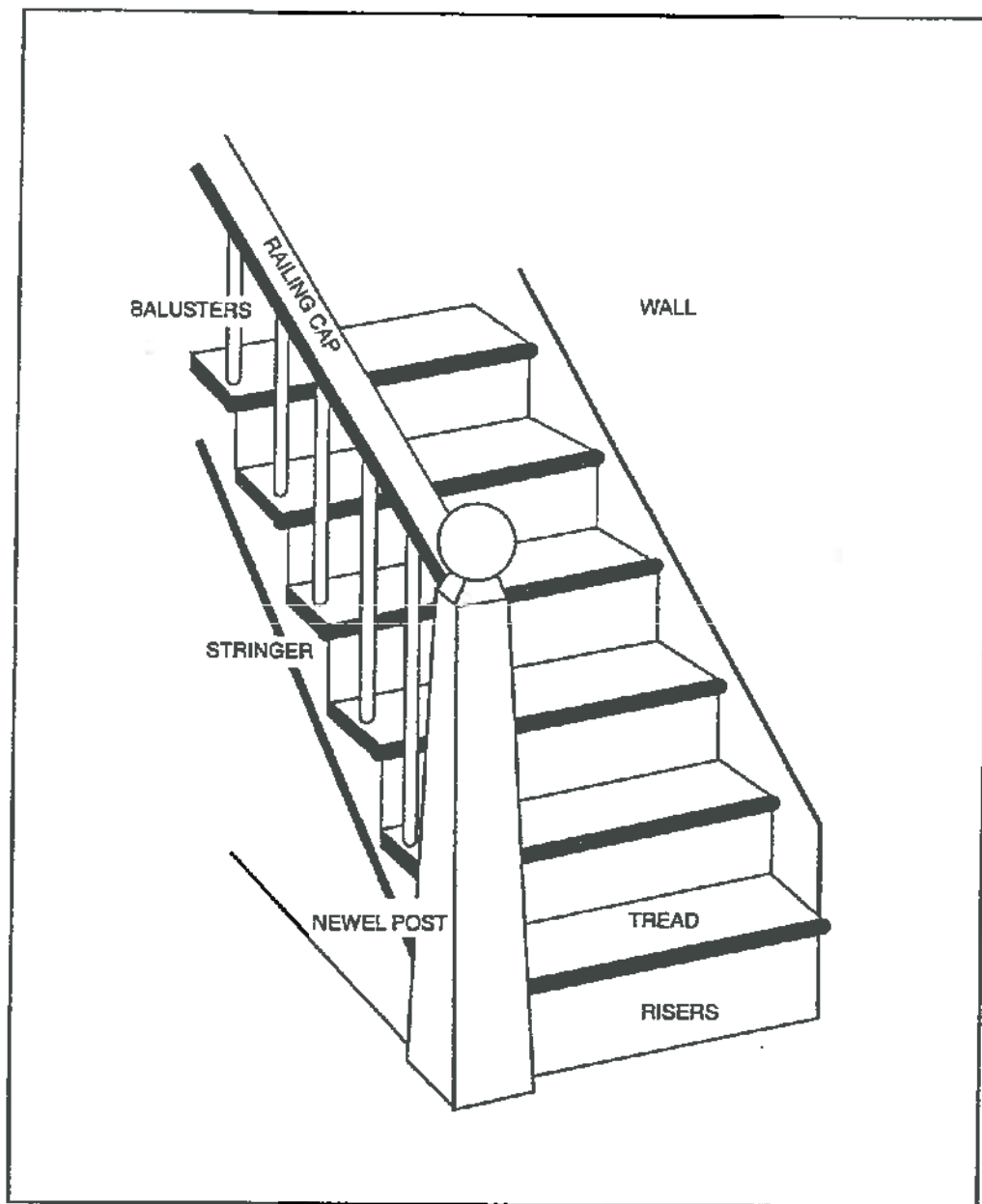



Figure 7-2
Diagram of Building Components





Inspecting for Lead-based Paint

**Figure 7-3
Diagram of Building Components**

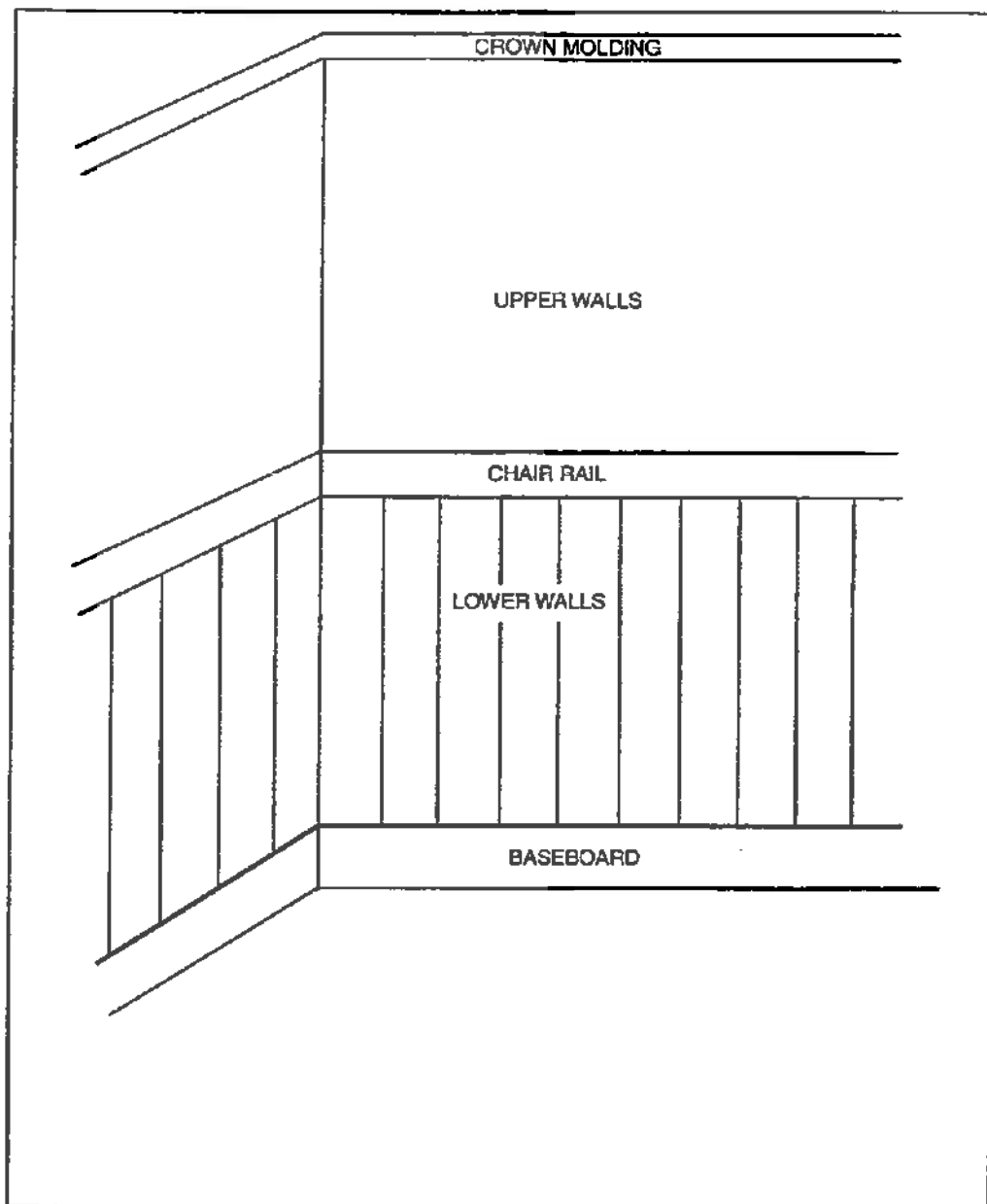



Lead-based Paint Testing Operations

Figure 7-4
Diagram of Building Components

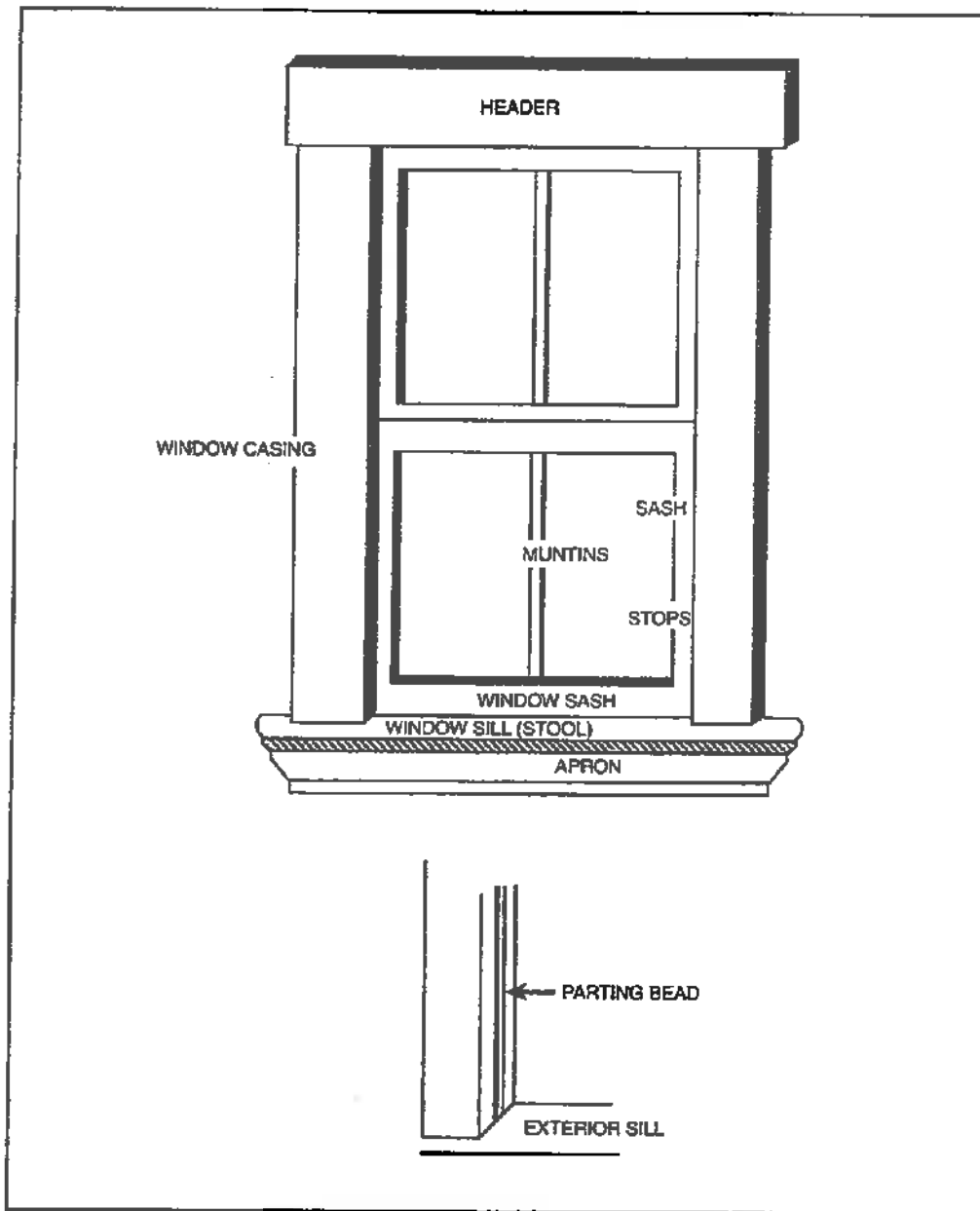
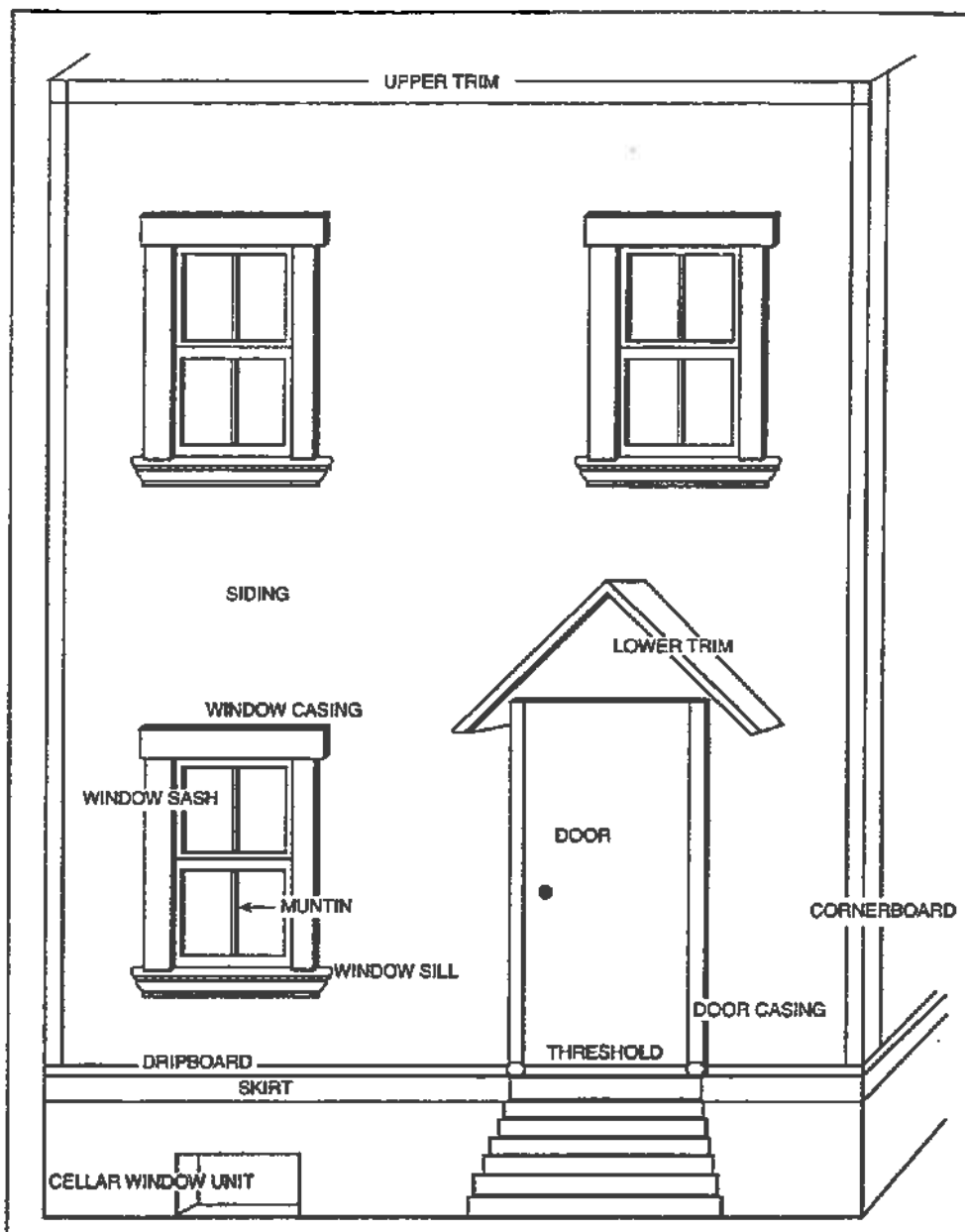



Figure 7-5
Diagram of Building Components





Lead-based Paint Testing Operations

Figure 7-6
Diagram of Building Components

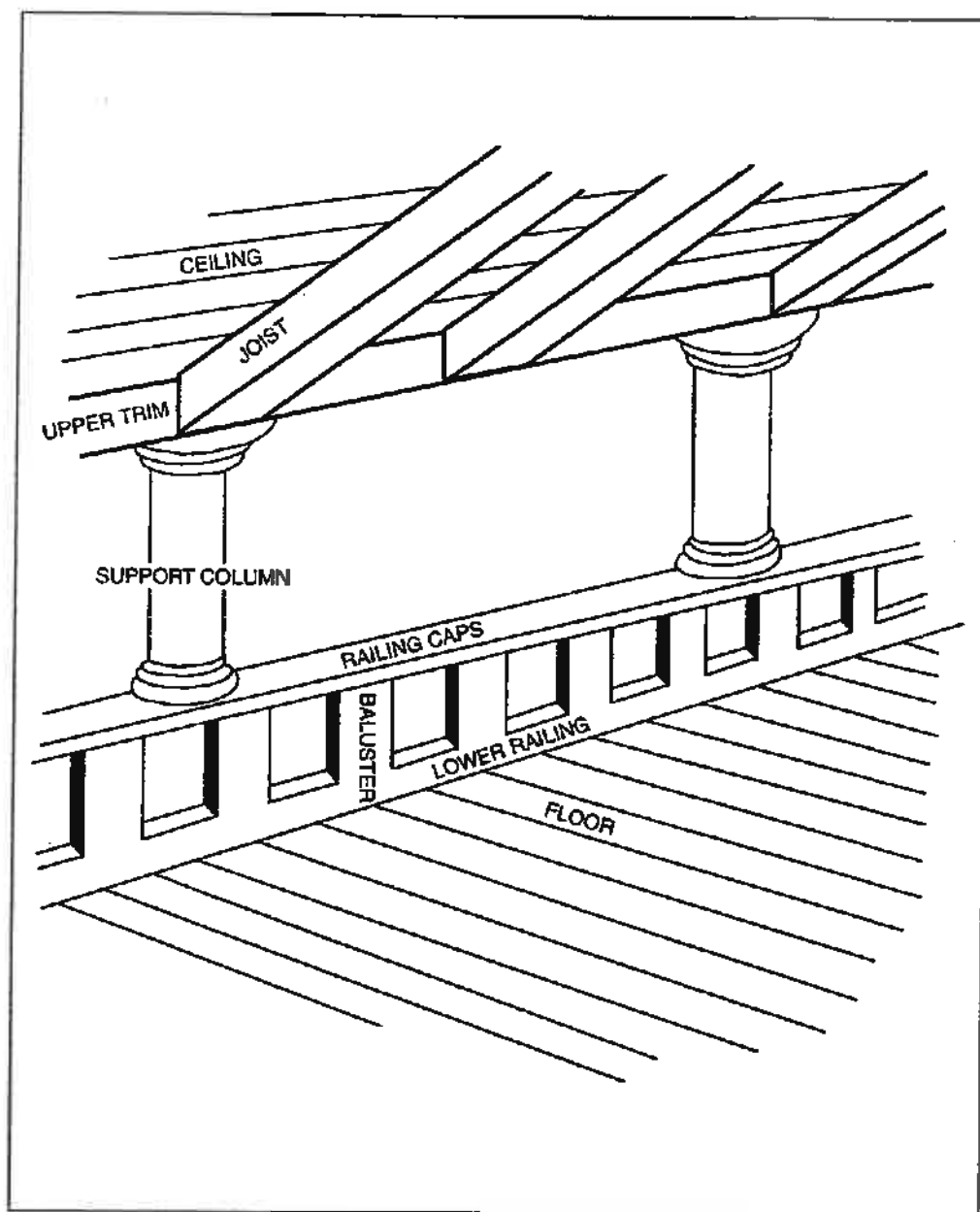
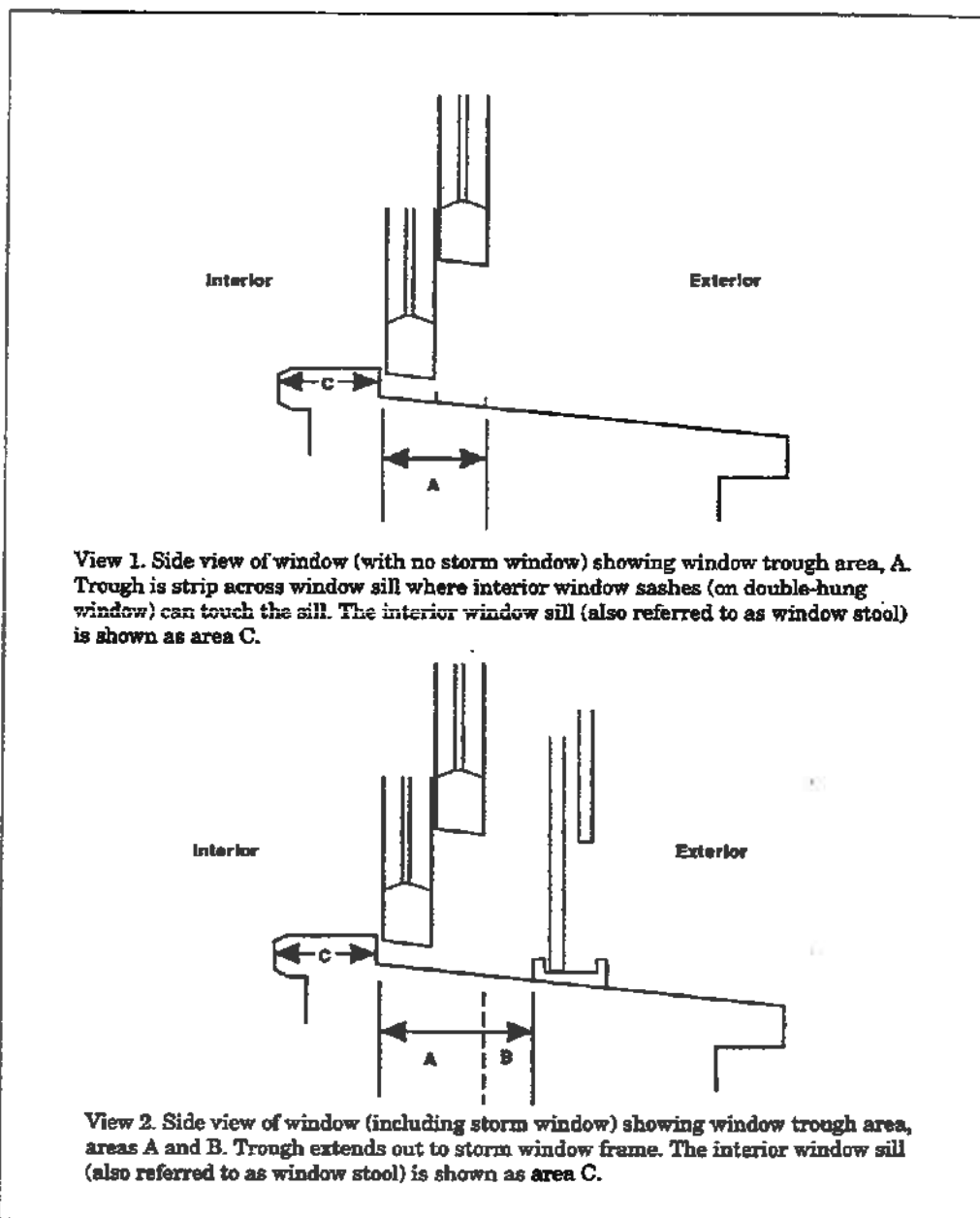



Figure 7-7
Diagram of Building Components





Lead-based Paint Testing Operations

Inspection Steps

When conducting any type of inspection, following a methodical step-by-step approach is very important. It helps prevent errors, omissions, and protects the inspector in case the inspection results are ever challenged or questioned. Without a detailed protocol to follow on each inspection, the chances of missing components, and therefore lead-based paint, are more likely. When conducting a lead-based paint inspection, the seven steps¹ listed below should be followed, regardless of whether one is conducting a multifamily or single-family housing inspection:

- 1 List all painted testing combinations by room equivalent, including those that are stained, shellacked, varnished, coated, or painted and covered with wallpaper which covers painted surfaces;
- 2 Select testing combinations;
- 3 Perform XRF testing (including the calibration check readings);
- 4 Collect and analyze paint-chip samples for testing combinations that cannot be tested with XRF or that had inconclusive XRF results, if applicable;
- 5 Classify XRF and paint chip results;
- 6 Evaluate the work and results to ensure the quality of the paint inspection;
- 7 Document all findings in a report.

Steps 1 through 3 are usually done concurrently.

Follow a step-by-step approach when conducting LBP inspections.

¹ HUD *Guidelines for the Evaluation and Control of Lead-based Paint Hazards in Housing*, June 1995, rev. 1997.



Testing in Single-Family Housing

Testing in single-family housing differs from multifamily unit testing in that the decision to abate is based upon sampling in a single unit. For multifamily testing, certain units and common areas are selected for sampling and, within each of those units, a representative sample of all testing combinations with common construction and painting histories are tested. Since there is only one unit involved in the decision for single-family testing, all testing combinations should be tested.





Lead-based Paint Testing Operations

Inventory and Selection of Painted Surfaces

An inventory of the painted surfaces in interior rooms, on exterior walls, and on surfaces in other exterior areas (e.g., fences, playground equipment, and garages) should be conducted using the *Single-Family Housing LBP Testing Data Sheets* found in Appendix A (or equivalent). There are separate data sheets for single-family and for multifamily housing inspections. Always start a new data sheet when moving to test a new room equivalent. If your XRF analyzer's software generates the data in a standard format, each room equivalent must be identified. This inventory may be completed either before any testing or on a room-by-room basis during testing, whichever the inspector prefers. Many inspectors find conducting a room-by-room inventory during testing saves time.

In order to document more accurately the surfaces tested and their location within the dwelling, either a detailed written description of the testing combinations or a detailed diagram of the floor plan of the unit, or preferably both, should be produced and provided with the final report to the client.

There is a benefit to all lead-based paint inspectors using the same scheme for diagramming a unit during any lead-based paint inspection. It makes interpreting the results of any lead-based paint inspection easier. Therefore, this curriculum presents one such method for diagramming the room equivalents and building components within any dwelling unit. If used properly and applied systematically, this approach will aid the client by allowing the labeling scheme to identify the test location on any testing combination.

The XRF analyzer may come equipped with software that provides a systematic labeling scheme. If so, become familiar with the software and include a "key" in the report so the client can understand what was tested and where. It is important that the labeling scheme provide a unique descriptor (alpha or numeric designation) for each room equivalent. The final report should include a brief description of whatever documentation method is used.

Make a rough sketch of the property

The property sketch should include a floor plan of each building or structure on the property. It should also include any additional structures that will be tested including fences, air conditioners, latticework, and play structures. (See Figure 7-8.)

Always start a new data sheet when moving to test a new room equivalent.



Inspecting for Lead-based Paint

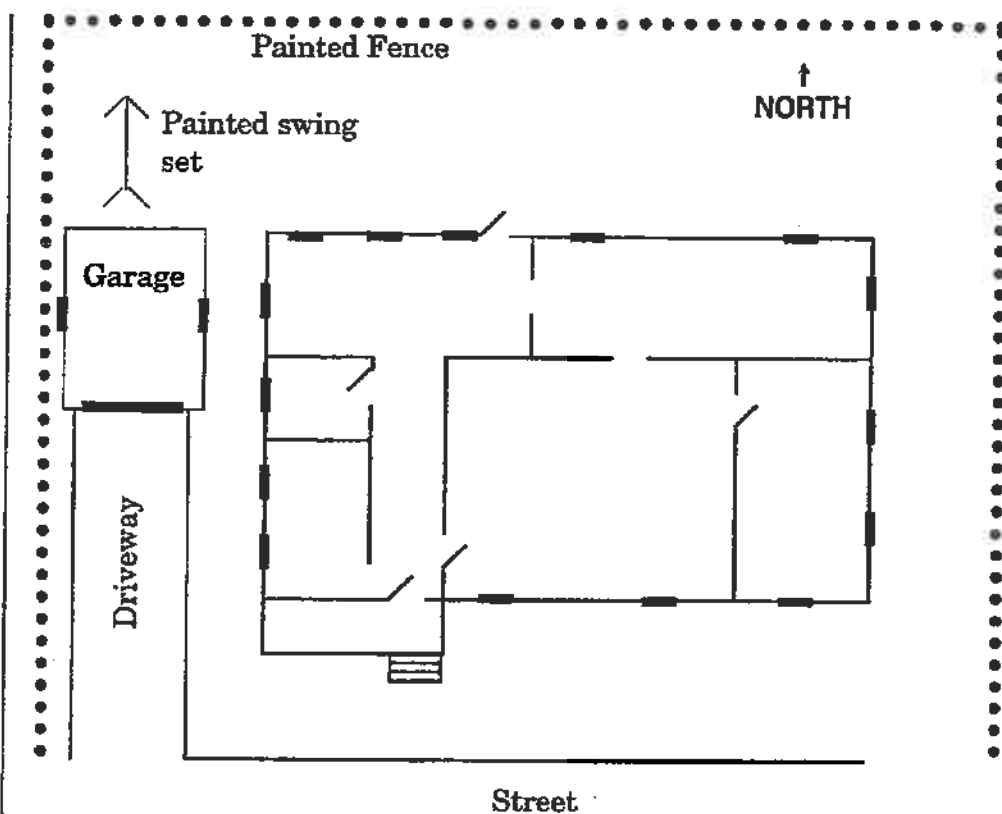

Figure 7-8. Simple diagram of the property

Identify and label the “street” or postal address side of each structure.

Begin by labeling the street side of the dwelling with an “A” and continuing in a clockwise direction and label each side of the dwelling with a letter. In the case of corner lots, the side with the postal address would be labeled “A.”

For most housing, determining the address side of the building presents no challenge. Since each side of the building will be labeled with a different designation (in this case A through D, unless the house has more than four sides; then, use as many letters as it takes) it make sense to always have the street side labeled first and proceed clockwise from there. Some inspectors have relied on directional labels (i.e., east, west, south, or north). That option requires a compass for accuracy and housing is not always built facing directly south, east, west or north, therefore requiring the use of multidirectional labels like northeast, or southwest.

Another method is to start labeling with the front of the dwelling. With our country’s diverse architectural and construction styles, the “front” of a house might be difficult to determine. It is rumored that, in the past, residential taxes were assessed based on how many feet of the structure was on the frontage or street side of a piece of property. This resulted in homes in cities like Charleston, South Carolina and Savannah, Georgia,

The “A” side is the side of the dwelling facing the street.



Lead-based Paint Testing Operations

being constructed "sideways," with the narrowest portion of the house on the street side and the front entrance facing the side yard.

In situations where the house is set back some distance from the street or road, the inspector may have to use his/her judgement to determine which side is the address side of the dwelling. Again, a quick sketch of the house and lot can make it clear to anyone who reads the report how the house was labeled.

Whatever labeling method is used, it must be one that can easily be understood and repeated in a variety of housing styles.

Label room equivalents by use and number clockwise

After determining the "street" side of the dwelling and labeling each side of the house with a letter, begin labeling room equivalents by number. In situations where a room equivalent is clearly used for one function (e.g., kitchen and bathroom), it is best to label them by name *and* number. In the case where there is more than one room with the same function, use both designations to differentiate between the rooms (e.g., bathroom-3 and bathroom-9).

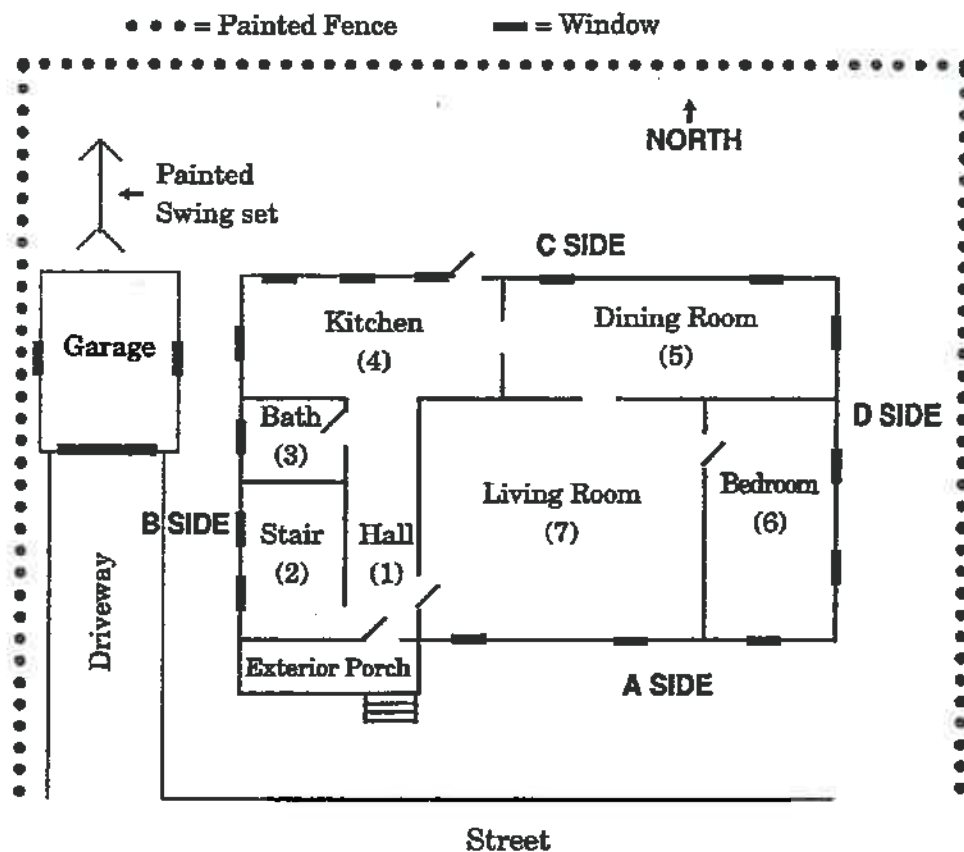

Label room equivalents by use and number clockwise.

Figure 7-9. Label room equivalents



Inspecting for Lead-based Paint

In multilevel dwellings, make a separate drawing of each level, and the room numbering should continue with the next consecutive number. In Figure 7-9 the first room on the second floor would be room number 8. When a dwelling includes a basement with painted building components, the inspector should start numbering in the basement and then proceed to the higher floor(s) or levels.

Walls within rooms can also be designated by A, B, C, or D by orienting oneself in the room and labeling the walls based on the exterior side labeling. Therefore, the walls in the hall (room #1) would be wall "A" and wall "D." However, when the inspector is testing the same wall, from the stairway (room #2) that the wall "A" from the hall would now be wall "D."

Identify like components by numbering left to right

Once the lot/floor plan has been sketched and each room equivalent assigned either a name or number or both, a testing data sheet is filled out for *each room equivalent*. Therefore, for the dwelling sketched in Figure 7-9, the inspector would have

- seven separate data sheets for the interior of the house;
- one data sheet for the exterior (all sides of a building can be treated as a single room equivalent *if* the paint history appears to be similar);
- one for the exterior porch;
- one for the exterior of the garage;
- one for the interior of the garage (if painted); and
- one for the playground equipment and fence,

for a total of twelve separate testing data sheets.

Within each area, list all painted, stained, shellacked, and varnished testing combinations which are candidates for testing. Remember, a *testing combination* is made up of the

- room equivalent,
- component, and
- substrate.

Table 7-2 provides examples of different testing combinations. The first example is a bedroom wooden door. This is a testing combination because it is described by a room equivalent (bedroom), component (door), and substrate (wood). Testing combinations that are *known* to have been replaced after 31 December 1977 probably do not contain lead-based paint and need not be tested.

Identify like components by letter and number.

When testing a painted substrate on top of another substrate, the substrate directly beneath the paint should be used.



Lead-based Paint Testing Operations

Table 7-2
Examples of Testing Combinations

Room Equivalent	Component	Substrate
Master bedroom (room 5)	Door	Wood
Master bedroom (room 5)	Door	Metal
Kitchen (room 3)	Wall	Plaster
Garage (room 10)	Floor	Concrete
Exterior	Siding	Wood
Exterior	Swingset	Metal

If the substrate type is not one of the six types, the inspector must determine the substrate type that most closely matches the true substrate (e.g., painted ceramic tile would most closely match a brick substrate). When an inspector encounters substrates on top of substrates (composite materials), such as plaster over concrete, or drywall over plaster, the substrate directly beneath the painted surface should be used.

Although paint color is not a criterion for determining a testing combination, the color of paint should be included for each sample. Since more than one color may be observed when paint is peeling or the substrate is damaged, both "white" and "blue over green" would be acceptable color entries. It is important to note in the final report that the color of any component could change as a result of future painting. Therefore, the client should rely on the location specific information to verify a sample site.

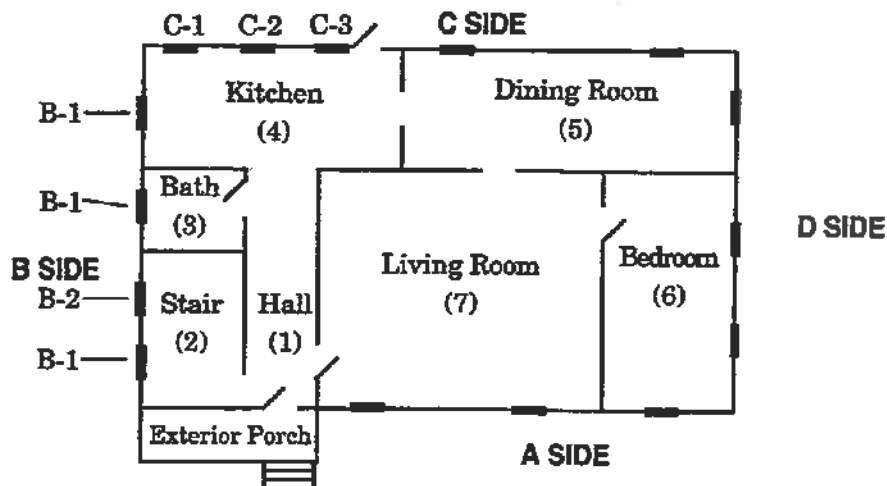

Figure 7-9. Identify testing combinations by number



Inspecting for Lead-based Paint

Once the inspector has begun identifying components and testing combinations within each room equivalent, he/she needs to identify which ones to test. In the case of the previous diagram, several rooms have more than one window. In each room equivalent, only one window casing system and one window sash system need to be tested if the inspector is fairly certain that the painting history of each of the windows is the same. Whenever there is reason to believe that the painting history may differ, use caution and do more testing. The most recent generation of portable XRFs are able to test very quickly (assuming a relatively new source), therefore, testing more components doesn't add much additional time to the inspection.

If there are multiple building components repeated within a room equivalent, the inspector should assign a *number* to each component in order to distinguish one window or one door from another. This number should incorporate the side on which the component is located. Facing the components, they are numbered from left to right (see Figure 7-9). In the drawing, the two windows in room 2 (the area containing the stairway), are numbered from *left to right*, B-1 and B-2. Moving to the kitchen (room 4), there is also a window in the "B" wall of the kitchen. It is also numbered B-1, however any testing information would be noted on a *separate* data testing sheet because it is located in a different room equivalent. Therefore, there should never be two building components labeled with the same designation on a data testing sheet. To continue numbering the windows in the kitchen, the windows on the "C" wall are numbered C-1 through C-3 from left to right. In the case of the kitchen, it is only necessary to test one complete window of the four windows (if the inspector determines that they are all likely to have the same painting history). As an example, an inspector could choose to test the sash from window B-1 and the casing from window C-2.

The inspector must test a surface that is representative of each type of painted, stained, shellacked, or varnished testing combination in every room equivalent.

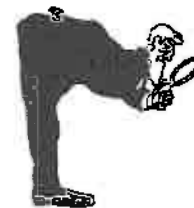

Lead-based Paint Testing Operations

Calibration Checks

As discussed in Chapter 5 on XRF theory and use, each portable XRF instrument has a *Performance Characteristics Sheet* (PCS) which must be followed. Before any testing can be done, the inspector must ensure that the XRF analyzer is operating properly.

A check of the instrument's calibration is the first step to ensure proper operation of the instrument and determine that the data generated during the inspection is accurate. The procedure for doing a calibration check was covered in detail in Chapter 5 and should be reviewed before initiating testing. At a minimum, this check must be done:

- at the beginning of each inspection
- at least every four hours, and
- at the end of each inspection.

Once testing has begun, a second calibration check must be conducted *at least* every four hours or at the end of testing, whichever occurs first. Some inspectors choose to check their instrument's calibration more frequently. Checking the instrument's calibration more often reduces the amount of data lost should the intermediate or final calibration check result in readings outside of the tolerance limits for that instrument, or if the machine stops working, or has to be turned off for battery replacement. When testing a number of units within a day, it is not necessary to conduct a calibration check at the end of each unit *as long as the XRF is not turned off*. However, the inspector must conduct the calibration check *before* turning the instrument off. Once an XRF analyzer is turned off, a new set of calibration checks should be done when the instrument is turned on again.

Readings not accompanied by successful calibration checks at the beginning and end of the testing period are unreliable and should be repeated after a successful calibration check has been made. If a backup XRF instrument is used as a replacement, it must successfully pass the initial calibration check test before retesting the affected test locations.

Once testing has begun, a second calibration check must be conducted at least every four hours or at the end of testing, whichever occurs first.



Test one location per testing combination; four readings, one on each wall

Number of Readings on Each Testing Combination

The test location is a specific area on a testing combination where XRF instruments will test for lead-based paint. For single-family housing, the HUD *Guidelines* recommend XRF testing on at least

- one location per testing combination, except interior and exterior walls;
- four readings, one on each wall (interior room equivalent or exterior).

The additional testing on interior and exterior walls is required because of the large surface areas and quantities of paint involved, as well as an increased possibility of spatial variation (how much the lead content changes across a given surface) on such a large surface.

When testing interior walls, for each set of walls with the same painting history in a room equivalent, test the four largest walls. Classify each wall based on its individual XRF reading. If a room equivalent has more than four walls

- calculate the average of the four readings,
- round the result to the same number of decimal places as the XRF displays,
- classify remaining walls with the same painting history as the tested walls based on this rounded average.

When the remaining walls in a room equivalent clearly do not have the same painting history as that of the tested walls, test and classify the remaining walls individually. Some walls may be divided by a chair rail or plate rail—decorative pieces of trim running horizontally from corner to corner. Sometimes the lower wall has a different finish than the upper wall. One common example is wainscoting—often tongue and groove wood boards installed vertically on the lower half of the wall beneath a chair or plate rail (see Figure 7-3). Question: How many locations should an inspector test if all four walls in a dining room were constructed as shown in Figure 7-3)? Remember the definition of a testing combination (substrate type, component type, and room equivalent). Answer: Since the lower wall is of a different *substrate type* (wood versus plaster or drywall), four tests of the lower wall and four tests of the upper wall would be required. This is in addition to one test of the chair rail.

For exterior walls:

- select at least four sides;
- average the readings (rounding the result as described above) to obtain a result for any remaining sides.

When upper and lower walls have a different painting history, four tests are required of each!



Lead-based Paint Testing Operations

If there are more than four walls and the results of the tested walls do not follow a classification pattern (for example, one is positive and the other three are negative), *test each wall individually.*

Selection of Test Locations

The selection of the test locations should be representative of the paint over the areas which are most likely to be coated with old paint or other lead-based coatings. Thus, locations where the paint appears to be thickest should be selected. Locations where paint has worn away or been scraped off should not be selected. At each test location

- include all layers of paint;
- lay the XRF probe faceplate flat against the surface.

Areas over pipes, electrical surfaces, nails, and other possible interferences should be avoided if possible. These materials may contain lead and contribute to the XRF reading.

When testing combinations are repeated within a room equivalent (e.g., window or door systems), one test should be taken on one part of the component system (e.g., the casing from window B-1) and another test from another part of the system from a separate component (e.g., the sash from window C-2). The same strategy would apply to door systems. If a room has two or more doors (including closet or pantry doors), test the casing or jamb of one and the door itself of another. If each door may have a different painting history, test each door system separately! Document exactly which component was tested in text on the testing data sheet and by a notation on the diagram.

If the dwelling has varnished, stained, or similar clear-coated floors, the HUD *Guidelines* protocol allows the inspector to take a reading in only one room equivalent *if* the coating is the same throughout other room equivalents. Therefore in the example house diagram used earlier, if all the rooms except the kitchen and bathroom had hardwood floors with the same stain and coating, only one reading of the floors would be required. The reading would be documented on the *Testing Data Sheet* for the room in which it was taken.

If acceptable locations cannot be found for XRF testing, a single paint-chip sample including all paint layers should be collected from each testing combination within each room equivalent. (More information on paint-chip sampling begins on page 7-67 in this chapter.)

The test location should represent areas which are most likely to be coated with old paint or other lead-based coatings.

Distribute test locations on components repeated within a room.



Testing on Nonflat Surfaces

Some of the surfaces listed which must be tested are not entirely flat. Since XRF analyzers are calibrated to provide accurate readings on flat surfaces, great care must be taken when surfaces are not flat. The best procedure is to locate a section of the component to be tested which is as large and as flat as possible. For example, in some older homes the baseboard and crown moldings and the window and door casings are large enough so that a flat place to test can be found.

There will be cases in which no flat section will be available (for example, a radiator or particularly decorative piece of molding). Such surfaces must be tested by scraping the paint and submitting the sample to a laboratory for testing. In cases where the client does not want any paint chips collected, the inspector should assume the paint is lead-based paint without collecting a paint chip. However, the reverse *is not true*. **An inspector must never assume paint in a pre-1978 dwelling is not lead-based paint without testing!** An inspector is not required to test post-1977 building additions or component replacements.

It is important that the inspector include any assumptions in the final summary page of the report so it is clear to all who read the report that some surfaces were not tested, but were assumed to contain lead-based paint.

If a surface cannot be tested with an XRF, a paint sample must be submitted for laboratory analysis or the surface must be assumed positive.

Lead-based Paint Testing Operations



Abbreviation of Testing

In housing where similar building component types with identical substrates (for example, wood windows throughout the dwelling) are all found to contain lead-based paint within the first five interior room equivalents, the HUD *Guidelines* protocol allows the inspector to stop testing *that component type*. (Again, the reverse is not allowed—even if the wood windows in the first five room do not contain lead-based paint, the inspector *cannot* assume that the remaining windows are painted with nonlead-based paint.) The inspector *must* obtain the client's permission to abbreviate the testing before discontinuing testing. The client's agreement must be clearly spelled out in the scope of work for the project *before* beginning the inspection. Also, include a statement in the final report that testing was stopped and that any untested components of the specified component type in the remaining rooms were assumed to contain lead-based paint.

The *Guidelines* allow abbreviation of testing under certain circumstances.



Sometimes XRF readings are subject to systematic biases.

Some XRFs do not need to have their readings corrected for substrate bias; some do.

XRF results are corrected for substrate bias by subtracting a correction value.

XRF readings of 4.0 mg/cm² or higher do not need to be corrected for substrate bias!

Substrate Correction

Sometimes XRF readings are subject to systematic biases (either high or low) caused by interference from the substrate material beneath the paint. The magnitude and direction (positive or negative) of bias depends upon

- the substrate,
- the specific XRF instrument being used, and
- factors such as temperature and humidity.

Some XRF instruments do not need to have their readings corrected for substrate bias. Other instruments may only need to apply substrate correction procedures on specific substrates or when XRF results are below a certain value. As explained in detail in Chapter 5, the bias is inherent in the physics of x-ray fluorescence. However, some instruments compensate for this bias better than others. The *XRF Performance Characteristics Sheet* (PCS) for the instrument(s) used during the inspection should be consulted to determine the requirements for each specific instrument. The PCS will state which substrates require correction, if any, and which do not. The use of XRF instruments which do not require correction for any substrate, or require corrections on only a few substrates, can simplify and shorten the inspection process.

XRF results are corrected for substrate bias by subtracting a correction value. This substrate correction value is determined separately in each house for each type of substrate. Currently, only XRF results below 4.0 mg/cm² require substrate correction, and only when indicated on the PCS for the XRF used in the testing. Future models of XRF analyzers may establish a different lead level below which substrate correction is required.

In summary, the need for substrate correction when using an XRF analyzer is determined by:

- the PCS for the XRF analyzer;
- the substrate;
- initial XRF readings less than 4.0 mg/cm².

Substrate Correction in Single-Family Housing

Substrate correction in single-family housing is done after all XRF testing in a house has been completed but before the final calibration check test has been conducted. Below is the procedure for substrate correction.



Lead-based Paint Testing Operations

- Review XRF results for each substrate type to determine if any readings fall within the range for substrate correction for a particular substrate (i.e., < 4.0 mg/cm²).
- For each substrate type for which substrate correction is required (instrument specific), create a list of all testing combinations with uncorrected XRF results less than 2.5 mg/cm², if substrate correction is needed at all (instrument specific).
- Select two testing combinations from the list generated.
- On each selected testing combination, choose a location from which to remove the paint. The locations should be based on the inspector's ability to remove paint thoroughly from the substrate, the similarity of the substrate, and the accessibility.
- Carefully remove the paint from each selected location using the methodology described later in this chapter for collecting paint-chip samples or ASTM E 1729 *Field Collection of Dried Paint Samples for Lead Determination by Atomic Spectrometry Techniques*.
- Using the same XRF instrument used during the inspection cover the bare area with a NIST SRM (1.02 mg/cm²) film and take three readings on the first bare substrate area. Record the substrate and XRF readings on the "Substrate Correction Values" form (see Appendix A) or a similar form. Repeat this procedure for the second bare substrate area and record the three readings on the form. A variant to this step is to take the readings on bare substrate. The need for this variation will be specified in the *XRF Performance Characteristics Sheet* for the affected XRF instruments.
- Compute the correction value for each necessary substrate type in the house by computing the average of all six readings and subtracting the NIST standard value as shown below. Record the results on the "Substrate Correction Values" form. If a NIST standard was used as directed by the PCS, make sure to subtract the NIST standard value from the average *before* transferring the values to the testing data sheet(s).

For each substrate type:

$$\frac{1^{\text{st}} + 2^{\text{nd}} + 3^{\text{rd}} + 4^{\text{th}} + 5^{\text{th}} + 6^{\text{th}} \text{ Reading}}{6} - \text{NIST standard value}$$

- Transfer the recorded correction values to the "Single-Family Housing LBP Testing Data Sheet" for each corresponding substrate.
- Correct XRF readings for substrate interference by subtracting the correction value from the XRF reading from each testing location where the initial reading is less than 4.0 mg/cm² or as indicated on the PCS.

Substrate correction readings are collected at a location on two testing combinations.



Inspecting for Lead-based Paint

Here is an example of a substrate correction calculation:

The XRF instrument's PCS indicates that substrate correction is required for metal:

Three readings from the first bare substrate area: 1.6, 1.3, 1.2

Three readings from the second bare substrate area: 1.5, 1.2, 1.4

Average of the six readings: 1.36666 (round to significant digits) = 1.4

Subtract the NIST standard (1.0 mg/cm²): 1.4 - 1.0 = 0.4

Substrate correction value for metal in this dwelling: 0.4 mg/cm²

Here is another example:

The same XRF instrument as in the example above:

Three readings from the first bare substrate area: 0.9, 1.1, 1.0

Three readings from the second bare substrate area: 0.7, 0.8, 0.8

Average of the six readings: 0.83333 (round to significant digits) = 0.8

Subtract the NIST standard (1.0 mg/cm²): 0.8 - 1.0 = -0.2

Sometimes the XRF instrument will produce a negative reading (e.g., -0.3 mg/cm², or -1.0 mg/cm²) as in the second example above. Most XRFs use a mathematical equation (an algorithm) in an internal computer to adjust the reading for the substrate effect. The internal computer has a handful of algorithms created from a range of common substrates and concentrations of lead. However, in the real world, there is a wide range of lead concentrations and there are hundreds of substrates with different densities and other variables (e.g., water content). In addition, there are compound substrates (i.e., one substrate over another as with aluminum siding over wood clapboard).

This means that the XRF's internal computer may incorrectly compensate for the substrate effect because it will choose the algorithm closest to that matching the substrate that the instrument detects. When the XRF display shows a negative number, it doesn't mean that the instrument is broken. It means that the algorithm is overcompensating for the substrate effect and other sources of error. This indicates that the instrument readings are biased low. Never discard or ignore negative readings. Record them and incorporate them into your final calculations and results. (If the negative number is too large [e.g., below -1.0 mg/cm²], it may mean that the instrument is in fact malfunctioning—reference the instrument's PCS and manufacturer's instructions on how to address this problem. If more than 20 percent of the corrected values are negative, the instrument's lead paint readings and/or the substrate readings are probably in error.)

Most XRFs use a mathematical equation in an internal computer to adjust the reading for substrate effect.

Never discard or ignore negative readings!



Lead-based Paint Testing Operations

Classifying Results

Once all XRF readings have been corrected for substrate interference (if applicable) the next step is to classify the results into *negative* for lead-based paint, *positive* for lead-based paint, or *inconclusive* based on the instrument's PCS. An inconclusive XRF result is any value falling within the inconclusive range on the PCS (including the boundary values defining the range).

In some cases, there is no inconclusive range. Instead the PCS specifies a value called the *threshold*. If the reading is less than the threshold, then the reading is considered negative. If the reading is equal to or greater than the threshold, then the reading is considered positive. Even though the federal definition of lead-based paint is 1.0 mg/cm², instruments with a low or high bias on a particular substrate may have a different threshold, such as 0.9 mg/cm².

The inspector must refer to the PCS for the XRF analyzer used for the testing to determine if the instrument has either an inconclusive range or a threshold value for each substrate tested. Different XRF models have different inconclusive ranges depending upon the specific XRF model, the mode of operation, and the substrate type.

Therefore:

- A *positive* classification indicates that lead is present on the testing combination at or above the federal standard of 1.0 mg/cm². A positive XRF result is any value greater than the upper bound of the inconclusive range, or greater than or equal to the threshold, as specified on the applicable XRF PCS.
- A *negative* classification indicates that lead is not present on the testing combination at or above the federal standard. A negative XRF result is any value less than the lower bound of the inconclusive range, or less than the threshold, as specified on the XRF PCS.
- An *inconclusive* classification indicates that the XRF cannot determine with reasonable certainty whether lead is present on the testing combination at or above the federal standard.

Positive, negative, and inconclusive results apply to the actual testing combination and to any repetitions of that testing combination that were not tested within a room equivalent. For example, in the housing example used earlier, the final classification for the window casing of window C-1 in room 3 (kitchen) would apply to all window casings within the kitchen *as long as* the inspector had determined that all window casings were a single testing combination. This should be indicated on the inspection report as one of the assumptions made during testing.

The next step is to classify the results into negative, positive, or inconclusive based on the PCS.



Inspecting for Lead-based Paint

Exercise One:

Acme's XRF PCS includes the following inconclusive ranges and threshold values.

Using the Acme XRF threshold values and inconclusive ranges, how would an XRF result of 0.9 mg/cm^2 on a plaster wall be classified?

Positive, negative or inconclusive?

Sample PCS
Acme XRF, Inc.

Substrate	Threshold Value	Inconclusive Range (in mg/cm^2)
Brick	none	0.71 to 1.29
Concrete	none	0.91 to 1.19
Drywall	0.9	none
Metal	none	0.91 to 1.09
Plaster	0.9	none
Wood	none	0.91 to 1.29

Questions:

How about a result of 0.9 mg/cm^2 on a concrete wall?

A result of 1.2 mg/cm^2 on a wood window sash?

The correct classifications are (fill in the blanks):

- the plaster wall is _____;
- the concrete wall is _____; and
- the window sash is _____.

Use of the inconclusive range and threshold is detailed in the PCS. The categories include substrate-corrected results if substrate correction is indicated. XRFs with *only* threshold values listed on the *XRF Performance Characteristics Sheet* are advantageous in that classifications of results are either positive or negative (i.e., no XRF readings are inconclusive).



Lead-based Paint Testing Operations

Inspections in Multifamily Housing

As mentioned earlier, for purposes of a lead-based paint inspection only, multifamily housing is defined as any group of units that are similar in construction from unit to unit with:

- 21 or more units if any were built before 1960 or are of unknown age, or
- 10 or more units if they were all built from 1960 to 1977.

Developments with fewer units should be treated as single-family housing.



In most respects, inspections in multifamily housing are conducted in the same manner as in single-family housing. However, there are some significant differences:

- additional interior and exterior areas must be inspected;
- a random sample of units are inspected;
- classification of XRF results by component type is required to determine development-wide patterns.

Substrate correction procedures, when applicable, also differ slightly. Each of these differences will be discussed in this section.

Common Areas

In addition to the interior and exterior of each unit in the sample, in multifamily housing the inspector must also test a representative sample of common areas in or around the building, both interior and exterior. For inventory purposes, each common area is treated the same way as a room equivalent (not a dwelling unit). However, for selection of which areas to inspect, the inspector follows the same selection process as when selecting which units to test. Examples of common areas include:

- | | |
|----------------------------------|---------------------|
| • hallways | • playgrounds |
| • stairways | • community centers |
| • laundry and recreational rooms | • boundary fences. |

In multifamily LBP inspections additional interior and exterior areas must be inspected.



Inspecting for Lead-based Paint

The components encountered in common areas are generally similar to those encountered in unit interiors and exteriors. However, the same testing principle applies: **a representative area on each painted, stained, shellacked, or varnished testing combination must be tested.**



Lead-based Paint Testing Operations

Computing Sample Size

The number of units to be tested (the sample size) is based on the total number of units, similar common areas or exterior sites in the building(s) *and* the date of construction as specified in Table 7-3. When *all* units, common areas, or exterior sites tested are found to be clear of lead at or above the 1.0 mg/cm² standard, these sample sizes provide 95 percent confidence that

- for housing units built before 1960, fewer than five percent or fewer than 50 (whichever is less) units, common areas, or exterior sites contain lead-based paint at or above standard; and
- for housing units built between 1960 and 1977, fewer than ten percent or fewer than 50 (whichever is less) units, common areas, or exterior sites have lead-based paint at or above the standard.

Appendix 12 of the HUD *Guidelines* presents the statistical rationale and calculations used to develop sample sizes in multifamily housing.

Once a group of similar buildings is determined, the inspector must decide how many units will be tested in that group. The first column of Table 7-3 indicates the total number of similar units, common areas or exterior sites in the building or group of similar buildings under consideration; the second and third columns indicate the number that should be sampled based on the age of the buildings or developments. Only some of the possible sizes are shown in Table 7-3. The table shows the number of units to be sampled for buildings or developments for each size up to 1039 units. For pre-1960 or unknown-age buildings or developments with 1,040 or more similar units, common areas, or exterior sites, test 5.8 percent of them and round up to the next whole number. For 1960-77 buildings or developments with 1,000 or more units, test 2.9 percent of the units and round up any fraction to the next whole number. (For reference, the table shows entries from 1500 to 4000 in steps of 500.)

Here are two examples. How many of each would an inspector test?

Example number one:

A development built in 1962 has the following:

- 522 similar units,
- 23 similar common areas, and
- 10 similar exterior sites.

Example number two:

A development built in 1945 has the following:

- 2,170 similar units,
- 45 similar common areas, and
- 15 similar exterior sites

Use Table 7-3 to determine how many units, common areas, and exterior sites to test.



Inspecting for Lead-based Paint

Table 7-3
Number of Units to be Tested in Multifamily Developments

Number of Similar Units, Similar Common Areas or Exterior Sites in a Building or Development	Pre-1960 or Unknown-Age Building or Development: Number to Test	1960-1977 Building or Development: Number to Test
1-9	All	All
10-13	All	10
14	All	11
15	All	12
16-17	All	13
18	All	14
19	All	15
20	All	16
21-26	20	16
27	21	17
28	22	18
29	23	18
30	23	19
31	24	19
32	25	19
33-34	26	19
35	27	19
36	28	19
37	29	19
38-39	30	20
40-48	31	21
49-50	31	22
51	32	22
52-53	33	22
54	34	22
55-56	35	22
57-58	36	22
59	37	23
60-69	38	23
70-73	38	24
74-75	39	24

Source: Table 7.3 of the HUD Guidelines.



Lead-based Paint Testing Operations

Table 7-3 (continued)
Number of Units to be Tested in Multifamily Developments

Number of Similar Units, Similar Common Areas or Exterior Sites in a Building or Development	Pre-1960 or Unknown-Age Building or Development: Number to Test	1960-1977 Building or Development: Number to Test
76-77	40	24
78-79	41	24
80-88	42	24
89-95	42	25
96-97	43	25
98-99	44	25
100-109	45	25
110-117	45	26
118-119	46	26
120-138	47	26
139-157	48	26
158-159	49	26
160-177	49	27
178-197	50	27
198-218	51	27
219-258	52	27
259-279	53	27
280-299	53	28
300-379	54	28
380-499	55	28
500-776	56	28
777-939	57	28
940-1,004	57	29
1,005-1,022	58	29
1,023-1,032	59	29
1,033-1,039	59	30
1,500	87	44
2,000	116	58
2,500	145	73
3,000	174	87
3,500	203	102
4,000	232	116

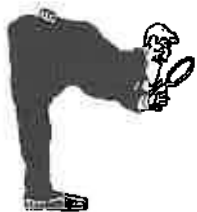
**Answers:****Example number one:**

The inspector uses Table 7-3 to determine that with 522 units in a development built between 1960 and 1977:

- 28 are tested;

With 23 similar common areas,

- 16 are tested; and
- all ten exterior sites are tested.

Example number two:

First, using the instructions regarding Table 7-3, an inspector would multiply 2,170 by 5.8%.

$$2,170 \times 0.058 = 125.86 \text{ (round up to the next whole number)} = 126$$

- therefore, 126 units would be tested;

Then, the inspector uses Table 7-3 to determine that with 45 similar common areas

- 31 are tested; and
- all 15 exterior sites are tested.

Selecting Housing Units

The first step in selecting units for inspection is to identify (based on written documentation or visual evidence) buildings in the development with a common construction and painting history. Such buildings can be grouped together for sampling purposes. *Units can have different sizes, floor plans, and number of bedrooms and still meet the criterion of commonality.*

The specific plan is defined as a listing of the specific dwelling units, common areas, and exterior areas to be tested (completely and clearly defined, for example, by address and unit number) and an inventory of the testing combinations in each room of each unit, each common area, and each building exterior. In order to develop the plan, the inspector should obtain from the client or develop:

- a complete listing of all units, unit numbers, and common areas in the development;
- information on the painting history of the development, if available;
- listings or drawings of common-area components; and
- information on building types and typical exterior components.

Units can have different sizes, floor plans, and number of bedrooms and still meet the criterion of commonality.



Lead-based Paint Testing Operations

The first task of the inspector is to carry out a visual inspection to verify the accuracy of the available information described above. Then, she/he must select the specific set of units to be tested. The HUD *Guidelines* state that only a sample of the units in a development must be tested if developments are uniformly painted at the time of construction and after that different units are painted in a random fashion. These assumptions support the idea that the housing authority or development owner/manager can determine the presence of lead-based paint by testing a sample of units. The benefits of this situation are clear:

- fewer units need to be tested;
- the development owner/manager can efficiently use the resources set aside for testing; and
- effort can be concentrated on doing a very accurate and effective job on those units which are tested.

When sampling a multifamily housing development for lead-based paint, the inspector has a choice. One option is to sample each unit and apply the result from each sample to the unit it comes from. This is like doing a series of single-family dwellings. Taking samples in every unit provides the most detailed information, but costs a lot. The other option is to sample just some of the units, selecting those units by a scientifically-valid approach, and then apply the results from those samples to the whole multifamily housing development. This approach is useful for development modernization planning. Taking samples in only some units costs less, but it also provides less information. To protect occupants if an inspector uses this option, when lead-based paint is found on a component type in any of the units sampled, the "positive" finding must be applied to that component type in all of the unsampled units. In other words, occupants of the unsampled units are protected when it is presumed that lead-based paint is present on the presumed-positive component types in their units, even if their units haven't been sampled.



Selecting the Specific Units

The next step in the plan is to determine the specific units to select. Suppose that a housing complex has 55 units and was built in 1948, so that 35 of these units will be sampled. The inspector must select the units at random. Random sampling will insure selection of the units is not influenced by preconceived notion or convenience and that each unit has an equal chance of being selected. The "Selection of Units" form (Table 7-4a) or a similar form may be used to aid in the selection process. This list can be in any order when using this procedure; however *all* units in each group of buildings must be considered eligible for testing. Next, the units should be numbered from 1 to the total number. In the example, the last unit number in the list will be 55. The random numbers are used to select which units out of the 55 to include.

At this stage, the inspector can choose to obtain either a table of random numbers, or a hand-held calculator which has a random number key, or use the random-number generating function of a computer spreadsheet software program. Tables of random numbers are often included in statistics texts which can be either purchased or obtained from a library. However, since hand-held calculators with a random number key can be obtained for under \$20, the example described here will focus on using such a calculator to obtain the random numbers.

A brief discussion on how these random number keys work may be useful. Each calculator will have a specific key or set of keys that must be depressed to produce one random number. The instruction manual for each calculator needs to be examined to determine exactly which keys to press. Each time a random number is obtained, a value will appear in the calculator which is between 0 and 1. The number of digits beyond the decimal point will be different for each calculator, but, typically, there will be at least three decimal places. (If the random number generation method used provides numbers of more than three decimal places, the inspector should use only the first three digits.) The concept behind these numbers is that any particular three digit number between 0 and 1 is equally likely to appear as any other. For example, depressing the sequence of keys to obtain one random number may result in the number 0.583 appearing on the display. A second time the number 0.107 might appear, and so on.

Random sampling will insure selection of the units is not influenced by preconceived notions or convenience.

When generating random numbers, use only the first three digits displayed.

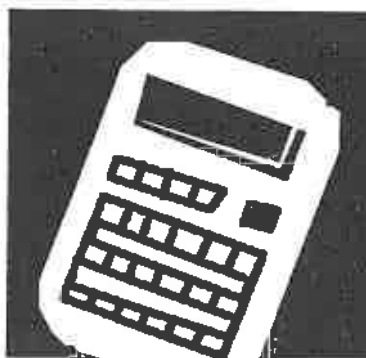



Inspecting for Lead-based Paint

The random numbers obtained from the calculator will be used to select the specific numbered units. The basic formula is:

Unit Number = Round up from (Random Number \times Total Project Size).

Using the same development size as on the previous page:

Random Number = 0.583 Total Project Size = 55.

Then, Unit Number is obtained by multiplying 55 by 0.583, which equals 32.065, and rounding *up* from there to the next whole number, which is 33. This means that the 33rd unit on the list of 55 is selected to be in the sample.

Suppose the next random number is 0.107. The product of 55 and 0.107 is 5.885, which rounds up to 6. This procedure continues until 35 different units are selected.

The same unit may be selected twice by this procedure. For example, suppose somewhere in the list of selected cases, the random number 0.595 is obtained. The associated product with 55 would be 32.725 which rounds up to 33. Since the 33rd unit can only be sampled one time, the duplicate selection is discarded and the selection process continues until the required 35 distinct units are selected. Alternately, as in this case, it would have been more efficient to randomly determine the 20 units that would *not* be inspected ($55 - 35 = 20$) and then to select the remaining 35 units for inspection.

Table 7-4b illustrates how to implement this calculation. If the calculation results in a unit which has not yet been selected, that unit is added as a new case in the "sample number" column. If a unit previously selected appears in this column ("Round up for Unit Number to Sample"), the entry in the last row is the word "DUP" (duplicate).

Table 7-4b was completed as follows. First fill in "Total Number of Units" column. Note that this number is the same down the entire column for the table. Then start with the column titled "Random Number." Use the hand held calculator repeatedly to fill in random numbers (as many as needed). The third column is obtained by multiplying the total project size (55 in this case) by the random number. The fourth column is obtained by *rounding up* from that calculation.

The final column, "sample number," is numbered consecutively until 35 separate units have been selected. If the value in that column is a repeat, that selection is not tested but is labeled as "DUP." The process continues until 35 unique case numbers are selected.

Unit numbers in buildings are not usually sequential (e.g., 101, 102, 202, 203). Therefore, a table matching the sample number to the unit numbers in the building(s) should be created. This is created by listing all 55 of the unit numbers and assigning the sample number to the correct unit number (sample number 1 was the 33rd unit on the list).

When selecting specific units, remember to always round up.

Lead-based Paint Testing Operations



Table 7-4b (Completed)
Selection of Units

Total Number of Units	Random Number*	Random Number times Total Number of Units Product	Round up for Unit Number to Sample	Sample Number
55	0.583	32.065	33	1
55	0.107	5.885	6	2
55	0.873	48.015	49	3
55	0.085	4.675	5	4
55	0.961	52.855	53	5
55	0.111	6.105	7	6
55	0.575	31.625	32	7
55	0.241	13.255	14	8
55	0.560	30.800	31	9
55	0.884	48.620	49	DUP
55	0.341	18.755	19	10
55	0.851	46.805	47	11
55	0.574	31.570	32	DUP
55	0.221	12.155	13	12
55	0.103	5.665	6	DUP
55	0.875	48.125	49	13
55	0.625	34.375	35	14
55	0.395	21.725	22	15
55	0.095	5.225	6	DUP
55	0.772	42.460	43	16
55	0.761	41.855	42	17
55	0.515	28.325	29	18
55	0.858	47.190	48	19
55	0.679	37.345	38	20
55	0.635	34.925	35	DUP
55	0.622	34.210	35	DUP
55	0.323	17.765	18	21
55	0.491	27.005	28	22
55	0.921	50.715	51	23
55	0.189	10.395	11	24
55	0.349	19.195	20	25
55	0.031	1.705	2	26
55	0.736	40.480	41	27
55	0.929	51.095	52	28
55	0.229	12.595	13	DUP
55	0.267	14.685	15	29
55	0.155	8.525	9	30
55	0.284	15.620	16	31
55	0.447	24.585	25	32
55	0.487	26.785	27	33
55	0.721	39.655	40	34
55	0.603	33.165	34	35

*Obtained from a hand-held calculator, spreadsheet program or textbook.

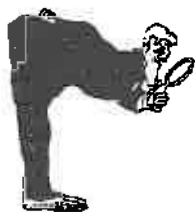

Inspecting for Lead-based Paint

This process is like putting all the unit numbers in a hat, and then picking one and then another while blindfolded.

In this example, the inspector has been asked to inspect an apartment complex called Palisade Apartments. Palisade Apartments has eight buildings in the complex:

- Three buildings contain six units each (all two-bedroom, one-bathroom per building). The unit numbers are 101-106; 201-206; and 301-306.
- Three buildings contain nine units each (eight two-bedroom, one-bath; and one three-bedroom, two-bath per building). The unit numbers are 401-409; 501-509; and 801-809.
- Two buildings contain five units each (four one-bedroom, one-bath; and one two-bedroom, two-bath per building). The unit numbers are 601-605 and 701-705.

Since all were constructed at the same time using the same building materials, they are all lumped together for the unit selection process for a total of 55 units.

Table 7-5 on the next page illustrates the unit selection process. The table is a listing of all 55 units in Palisade Apartments in numerical unit number order. The units to be tested have been circled. On Table 7-3 "Selection of Units," sample number 1 should be the 33rd unit on the list. In this example, that is unit 506. Sample number 2 should be the 6th unit on the list—unit #106. The inspector continues selecting the correct unit number based on the list of 55 units until all 35 units have been documented. The inspector proceeds with the inspection using this list of 35 units.

As a reminder, when an inspector encounters a multifamily development whereby the number of units to be tested is more than 50 percent of the total number of units, it is quicker to randomly select the units *not to test* instead of the units to test. All the units selected in the random selection process will *not* be inspected, the remaining units will be inspected.

Although not required by this protocol, it is a good idea for the inspector to select one or more units in addition to the minimum required, *in case* there is a problem accessing any of the units selected. This saves time in the field since the inspector won't have to repeat the selection process after inspections have begun. However, substitutions should be kept to a minimum. Too many substitutions can result in a biased (no longer random) sample.

Examples of nonrandom sampling (not permitted):

- picking the first ten units the inspector visits;
- picking units housing children;

Pick a few extra units in case there is a problem accessing any of the units selected.



Lead-based Paint Testing Operations

Table 7-5. Unit Selection Table

List of apartments in chronological order
(randomly selected units circled)

Palisade Apartments Listed in Chronological Order			
Sample #	Unit #	Sample #	Unit #
1	101	28	501
2	102	29	502
3	103	30	503
4	104	31	504
5	105	32	505
6	106	33	506
7	201	34	507
8	202	35	508
9	203	36	509
10	204	37	601
11	205	38	602
12	206	39	603
13	301	40	604
14	302	41	605
15	303	42	701
16	304	43	702
17	305	44	703
18	306	45	704
19	401	46	705
20	402	47	801
21	403	48	802
22	404	49	803
23	405	50	804
24	406	51	805
25	407	52	806
26	408	53	807
27	409	54	808
		55	809



- picking only units on the first floor;
- picking units where no one is home.

Each of these unit selection method is biased in some fashion. Random sampling ensures an *unbiased* sample.

Testing Combinations

The same procedure for selecting testing combinations described in single-family housing applies to multifamily housing. The only additional areas which must be tested are common areas and additional exterior sites.

- Common areas include hallways, lobbies, stairways, laundry rooms, and recreational and community centers.
- Exterior sites include garages, fences, and playgrounds.

There is no requirement to test painted stripes on driveways, parking garages or lots, etc.

Common Area Testing

Similar common areas and exterior sites should always be tested, but in some cases they can be sampled in much the same way as dwelling units. Common areas and building exteriors typically have a similar painting history from one building to the next. In multifamily housing, each common area (such as a building lobby, laundry room, or hallway) can be treated like a dwelling unit. If there are multiple similar common areas, they may be grouped for sampling purposes in exactly the same way as regular dwelling units. However, dwelling units, common areas, and exterior sites *cannot* be mixed together in a single group.

All testing combinations within each common area or on building exteriors selected for testing must be inspected. This includes playground equipment, benches, and miscellaneous testing combinations located throughout the development. The specific common areas and building exteriors to test should be randomly selected, in much the same way as specific units are selected using random numbers.

The selection of the test locations should be varied so that the universe of samples for each type of component in the multifamily development reflects the inspection of lead-based paint at a variety of locations. For example, if there are 60 exterior doors to be tested, 20 of them should be tested on the lower third of the door, 20 in the middle third, and the other 20 on the top third. Each door will require only one XRF reading.

Testing combinations in dwelling units, common areas, and exterior sites *cannot* be mixed together in a single group.



Lead-based Paint Testing Operations

It is very important for the inspector to follow the component testing guidance provided above as closely as possible. A thorough job of component testing in the selected units is absolutely essential in achieving the appropriate confidence level for the testing scheme as a whole.

Substrate Correction in Multifamily Housing

The method for correcting XRF readings for substrate bias should be performed as described for single-family housing with one exception: one representative location of a given substrate should be selected from each of *two* randomly chosen units for each substrate type. When available, vacant units are most often selected to minimize damage to painted surfaces in occupied units.

Care must be exercised in obtaining substrate corrections. If additional substrates exist in common areas or on exterior sites that do not exist in residential areas, select two locations from these areas for substrate correction. Otherwise, the same substrate correction readings can be applied to dwelling units, common areas and exterior sites.

One location of each substrate type should be selected from each of two randomly chosen units.



Classification of Components

Testing combinations are determined to be “positive” if the amount of lead-based paint on the paint surface equals or exceeds 1.0 mg/cm² or 0.5 percent by weight. The HUD *Guidelines* recommends classifying XRF results relative to the 1.0 mg/cm² whenever possible. However, if federal standards differ from state or local standards, the *most stringent standard* must be applied.

The inspector is required to record the measurement(s) for each testing combination and to indicate at the end of the XRF testing process whether that component is classified as

- *positive*: indicating that lead is present on a component type at or above the federal standard;
- *negative*: indicating that lead is not present on the testing combination at or above the federal standard;
- *inconclusive*: the XRF test result cannot determine with reasonable certainty whether lead is present on the component type at or above the federal standard.

It is important to note that positive, negative, and inconclusive results apply not only to the actual component type, but also to any repetitions of the component type in the room equivalents that were not tested. For example, suppose that a room equivalent contains four windows of the same substrate type. The inspector takes an XRF reading on the interior sash of one window and on the casing of another window. The resulting classifications would be based on the XRF result from the two tested windows, but the classification also applies to all four window systems within that room equivalent.

Grouping Component Types

For multifamily housing, the inspector must record each XRF reading for each testing combination on the *Multifamily Housing LBP Testing Data Sheet*, or a comparable form, and indicate whether that testing combination was classified as positive, negative, or inconclusive. When the inspection is completed in all of the selected units, common areas, and exterior sites, and the classification rules have been applied to all of the results, the *Multifamily Housing: Component Type Report* form or a comparable form should be completed. This form groups *component types* in the multifamily housing development. A *component type* is a group of like components constructed of the same substrate. For example, grouping all walls would create an appropriate component type if all walls are plaster. However, grouping all doors would not be appropriate if some doors are metal and some doors are wood. It is important to remember that walls in areas likely to generate moisture (e.g., kitchens and bathrooms) are more likely to be painted with lead-based paint than

If state or local standards differ from the federal, the most stringent standard applies.



Lead-based Paint Testing Operations

other areas in a dwelling. This is because of the mildew and mold resistance and durability of lead-based paints. Therefore, an inspector may choose to group walls of kitchens and bathrooms together as one component type group and all other interior walls as another component. *At least 40 components of a given type must be tested to obtain the desired level of confidence in the results throughout the multifamily housing development.* (Refer to Appendix 12 of the HUD *Guidelines* for the statistical rationale for this minimum number of component types to test.) If fewer than 40 combinations of a given component type are tested using XRF instruments, additional combinations of that component type will need to be tested. If fewer than 40 components of a given type exist in the buildings to be tested, test all of the components that do exist.

In some cases additional sampling of the specific component may not be necessary. If no lead at or above the standard is found on the component, additional samples should be taken in other units to increase the sample size to 40. But if the sampled components contain lead above the federal (or state, Indian tribe, or local) standard, it may be concluded without further sampling that lead-based paint is present greater than or equal to 1.0 mg/cm² on all remaining, untested components of that type. For example, if 20 out of 60 metal doors are tested, and all or almost all have lead levels of 1.0 mg/cm² or greater, it may be concluded that all untested metal doors in the buildings are positive for lead. (Those doors that tested negative for LBP do not have to be treated as positive.) However, the opposite does not apply. **All of the required XRF testing must be completed to conclude that all components included in a given component type are negative for lead.**

On the *Multifamily Housing: Component Type Report* form, the substrate, component, and color (if necessary) for each component type should be recorded under "Description" (for example, interior wooden doors) as well as the total number of testing combinations included in the component type. Further, for each component type, the total positive, negative, and inconclusive classifications should be recorded as described below. Record the number and percentage of testing combinations classified as either:

- positive for lead-based paint relative to the federal standard
- inconclusive and having XRF readings less than the midpoint of the XRF's inconclusive range ("low inconclusive");
- inconclusive and having XRF readings equal to or greater than the midpoint of the XRF's inconclusive range ("high inconclusive"); or
- negative for lead-based paint relative to the federal standard.

Each of these classifications is based upon the PCS for the XRF(s) used during testing.

At least 40 components of a given type must be tested.



Inspecting for Lead-based Paint

The percentages are computed by dividing the number in each classification group by the total number of testing combinations in the component type.

Example PCS Threshold Values and Inconclusive Ranges

Substrate	Threshold Value	Inconclusive Range (in mg/cm ²)
Brick	none	0.71 to 1.29
Concrete	none	0.91 to 1.19
Drywall	0.9	none
Metal	none	0.91 to 1.09
Plaster	0.9	none
Wood	none	0.91 to 1.29

For example, there are 245 interior wooden doors in a multifamily housing development and 69 of them are classified as inconclusive. Of the 69 doors classified as inconclusive, 31 of them have XRF readings at or below 1.0 mg/cm², and 38 have XRF readings equal to or greater than 1.1 mg/cm² up to 1.29 mg/cm². Using the Acme XRF, the PCS states that the inconclusive range for wood is 0.91 to 1.29. The midpoint of the inconclusive range is easily determined by averaging the two numbers of the range.

In this example:

$$0.91 + 1.29 = 2.2$$

$$2.2 \text{ divided by } 2 = 1.1.$$

Therefore, readings below 1.1 to 0.91 are *low inconclusives* and readings at or above 1.1 to 1.29 are *high inconclusives*.

Since 69 doors of 245 tested were positive, the percentage of positives is $69/245 = 0.28 \times 100 = 28\%$

Low inconclusives: $31/245 = 0.126 \times 100 = 13\%$

High inconclusives $39/245 = 0.16 \times 100 = 16\%$

The "Multifamily Decision Flowchart" (Figure 7-7) should be used to interpret the aggregated XRF testing results in the *Multifamily Housing*:

Lead-based Paint Testing Operations

Figure 7-7 Multifamily Decision Flowchart

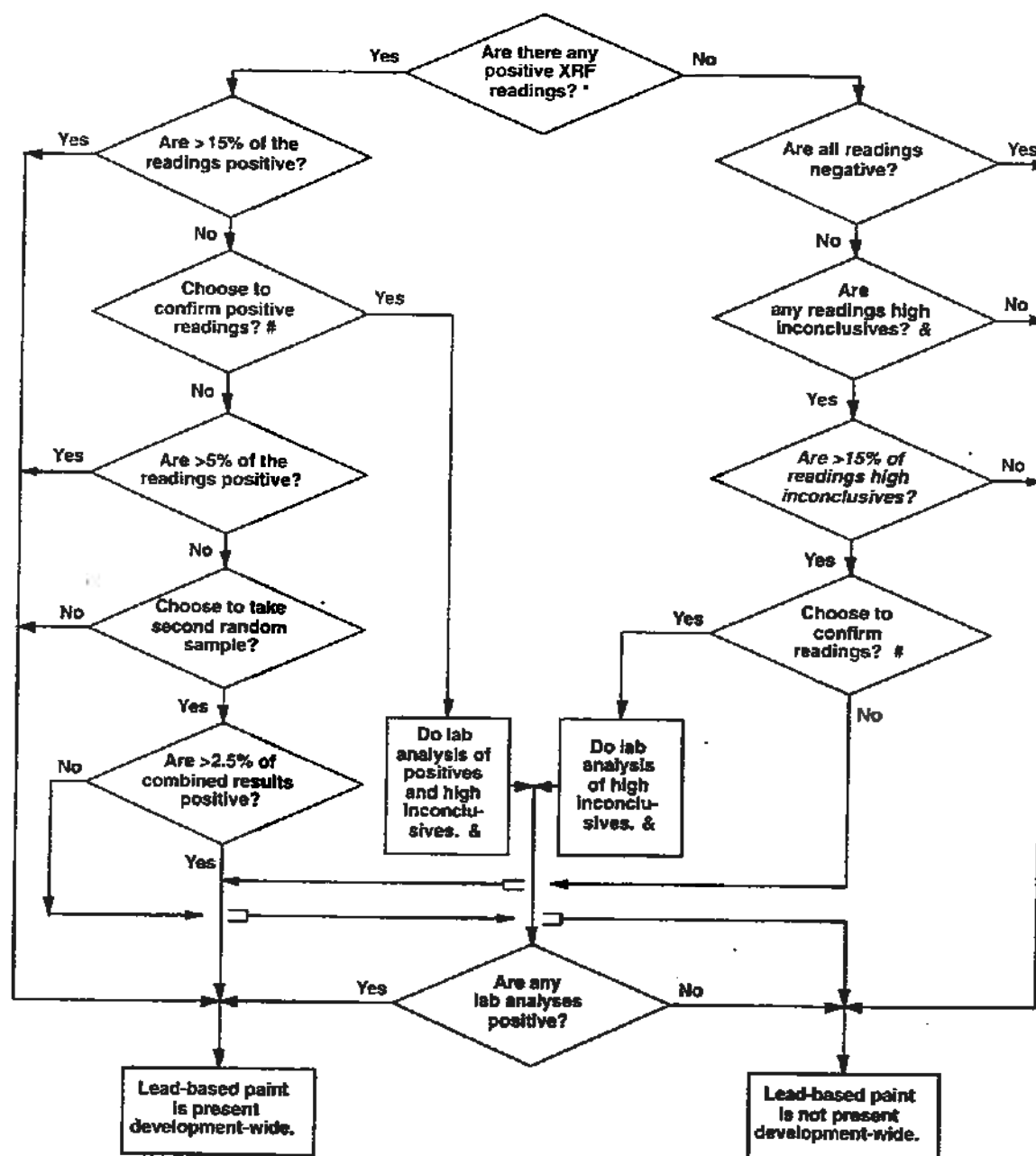

* "Positive," "negative," and "inconclusive" XRF readings are determined in accordance with the XRF instrument's Performance Characteristics Sheet as described in the HUD Guidelines for the Evaluation and Control of Lead-based Paint Hazards in Housing, Chapter 7 (rev. 1997).

& A high inconclusive reading is an XRF reading at or above the midpoint of the inconclusive range. For example, if the inconclusive range is 0.41 to 1.39, its midpoint (average) is 0.90; a reading in the range from 0.90 to 1.39 would be a high inconclusive reading.

Any paint or coating may be assumed to be lead-based paint, even without XRF or laboratory analysis. Similarly, any XRF reading may be confirmed by laboratory analysis.



Inspecting for Lead-based Paint

Lead levels in paint below the federal standard for LBP may still present a hazard if disturbed.

The multifamily housing sampling protocol is designed to identify component types that are likely to be negative for lead in all units.

Component Type Report form. The flowchart is applied separately to each component type (wood baseboards, metal doors, etc.) and indicates one of the following results:

Positive: Lead is present at or above the federal standard of 1.0 mg/cm² on *one or more* of the components.

Negative: Lead is not present on *any* of the components at or above the federal standard of 1.0 mg/cm². Note that lead may still be present and hazardous leaded dust may be generated during modernization, renovation, remodeling, maintenance, or other disturbances of painted surfaces. (NOTE: The OSHA lead in construction standard (29 CFR 1926.62) establishes minimum requirements for worker protection when employees are exposed to lead during these activities. These requirements *are not* triggered by the level of lead in paint; rather they are triggered by known or expected exposures to lead.)

These results are obtained by following the flowchart. The decision that lead is present at or above 1.0 mg/cm² is reached if 15 percent or more of the components are positive.

The decision that *no lead-based paint is present* is reached if:

- 1) 100 percent of the tested component types are negative, or
- 2) 100 percent of the tested component types are classified as either negative or inconclusive *and* all of the inconclusive classifications have XRF readings less than 1.0 mg/cm².

For all other cases, laboratory testing is required for validation. For each component with an inconclusive XRF reading of 1.0 mg/cm² (or 0.5 percent by weight) or greater, a positive result is indicated. Once all laboratory results have been returned, the *Multifamily Housing: Component Type Report* form should be updated to include the laboratory results and classifications (either positive or negative).

The percentages used in the "Multifamily Decision Flowchart" are based on data collected by EPA in a large field study of XRF instruments. The percentages were chosen so that, for each component type, there is a 98 percent chance of correctly concluding that lead-based paint is either absent on all components or present on at least one component of a given type. Thus, there is a very high probability that a tested component type will be correctly classified.



Lead-based Paint Testing Operations

Unsampled Housing Units

The approach described for multifamily housing is designed to use a sample of units to identify component types that are very likely to be negative for lead in *all* units of the development, both sampled and unsampled. Once these component types are identified, no further testing resources need to be allocated for components of those types.

Furthermore, if lead is present on a component type, this approach is very likely to identify *at least one* component of that type as having lead-based paint at or above the federal standard.

For those cases where the number of positive component types is small (i.e., only a few positives are found), the purchaser of the inspection services may choose to use the sample results along with building records to determine if there is a systematic reason for the specific mixture of positive and negative results.

For example, suppose that metal porch railings (a component type) were present in all units. A sample of these porch railings was inspected for lead-based paint and the results were classified as both negative and positive. Examination of the sample results along with the building records revealed that the porch railings that were classified as positive were all original and that the porch railings that were classified as negative were all recently replaced. The owner was then able to make conclusions about the unsampled porch railings. The owner concluded that 1) all of the *unsampled* original porch railings could be classified as positive, and 2) all of the *unsampled* recently replaced railings could be classified as negative if at least 40 of the replaced porch railings had been sampled. If fewer than 40 were sampled, the inspector must test additional replaced porch railings to bring the total tested up to 40 and reevaluate the final classification.

Fewer Than Five Percent Positive Results

For cases where a small fraction of XRF readings, less than five percent, of a particular component type in the sampled units are positive for lead, the purchaser of the inspection services may choose to take a second random sample, particularly if the use of building records does not resolve all issues. The same procedure should be used when selecting units for the second sample—the same number of units should be selected as for the first sample, and selections should only be taken from the list of unsampled units.

If the combination of the two sets of samples for a particular component type results in fewer than 2.5 percent positive classifications, the untested testing combinations can be classified as negative for lead-based paint and the owner may halt testing. Individual components in the samples that were classified as positive for lead-based paint should be managed appropriately as lead-based paint. If there are components

This protocol is very likely to identify *at least one* component of each type as having LBP at or above the federal standard.

A second random sample may be an option where less than five percent of the XRF readings of a component type are positive.



Inspecting for Lead-based Paint

classified as positive in the second sample, the owner should arrange for testing of the unsampled components in the remaining units at a convenient time, such as during unit vacancy or before renovation, or simply assume that all untested components are positive.

If the two samples combined have 2.5 percent or more components of a given type that are classified as positive, the location of lead-based paint must be determined by further testing of all components of that type or further investigation of building records together with the two sample results.

Whatever approaches are used, all painted surfaces found to be positive for lead relative to the federal standard must be reported in the summary page of the report. Additionally, the disclosure rule requires that any records or reports pertaining to lead-based paint or lead-based paint hazards be disclosed to the tenant or buyer of target housing.



Lead-based Paint Testing Operations

Quality Assurance and Quality Control Measures

The HUD *Guidelines* recommend that the *housing owner or client* evaluate the quality of a lead-based paint inspection employing one or more of the following measures:

- direct observation
- on-site results
- repeated testing
- time-and-motion analysis.

Direct Observation

Direct observation by a knowledgeable observer during the lead-based paint testing can be an effective evaluation tool. It is the only way to ensure that all of the painted, stained, varnished, shellacked, or wallpapered testing combinations are tested. It is also the only way to determine that all the XRF results are recorded correctly. This evaluation must be conducted by someone familiar with the HUD inspection protocol and, therefore, should be conducted by a trained inspector. To avoid any conflict-of-interest, this inspector should be independent of the inspection firm conducting the testing.

On-site Results

Another method of evaluating the quality of the inspection is to require the inspector to provide copies or printouts of testing results immediately following the completion of the inspection or on a daily basis (for multiple properties or multifamily housing). The client or their representative can review the data to ensure that all surfaces were tested and the results were properly recorded. These daily printouts should be retained by the client for comparison with the results included in the final report.

Repeated Testing

Data from HUD's low-income private housing lead-based paint hazard control program show that it is possible to successfully retest painted surfaces without knowing the exact spot that was tested. This retesting involves a complicated series of calculations that will provide a statistical confirmation that the inspection was conducted properly.

If this method of quality assurance is to be conducted, a statement that the inspector will, if requested, retest ten testing combinations should be included in the scope of work of the contract. These testing combinations should be selected at random from the completed *Single-Family Housing*

The *Guidelines* recommend several ways that the client can evaluate the quality of a LBP inspection.



Inspecting for Lead-based Paint

If retesting is used to verify the quality of an inspection, the same XRF instrument should be used.

LBP Testing Data Sheets or *Multifamily Housing LBP Testing Data Sheets*. In multifamily housing, the ten testing combinations should be selected for retesting from two units. The inspector should be observed during the retesting and *whenever possible* the same XRF instrument used during the original testing should be used for the retesting. If the same XRF instrument cannot be used, an XRF of the same model should be used. If these requirements are clearly spelled out in the testing contract documents, the inspector should be able to have the same instrument available.

After retesting the ten testing combinations, the average of the ten repeat XRF results should not differ from the ten original XRF results by more than the *retest tolerance limit*. The PCS for the XRF includes the procedure for calculating the retest tolerance limit. This value is computed using the following steps:

- calculate the average of the original XRF result and the retest XRF result for each of the ten testing combinations;
- conduct a series of mathematical calculations.

The easiest way to do these calculations is to set up a spreadsheet software program to do the calculations for you as shown in Table 7-6.

Using the retest tolerance limit of 1.9 from Table 7-6, the inspector then:

- computes the average of all ten original XRF results,
- computes the average of all ten retest XRF results, and
- finds the *absolute* difference of the two averages.

If the difference is less than the retest tolerance limit, the inspection has passed the retest. If the difference of the overall averages equals or exceeds the retest tolerance limit, this procedure should be repeated with ten new testing combinations. If the difference of the overall averages is equal to or greater than the retest tolerance limit *a second time*, the inspection should be considered deficient.

In our example, the absolute difference is less than the retest tolerances limit (0.25 is less than 1.9), so the inspection has passed the retest.



Lead-based Paint Testing Operations

Table 7-6 Sample spreadsheet for determining the Retest Tolerance Limit

Testing Combination	Initial XRF Result in mg/cm ²	Retest XRF Result in mg/cm ²	Average	Square the Average
Window sill Kitchen (C-1)	3.3	3.5	3.4	11.56
Baseboard Room 2 (D)	6.6	6	6.3	39.69
Fireplace mantel Room 2	5.8	6.2	6	36
Wall A Room 3	0.9	1.3	1.1	1.21
Wall C Room 5	1.1	1.4	1.25	1.5625
Window sash (D-2) Room 3	3.9	4.4	4.15	17.2225
Door (B) Room 4	2.7	2.5	2.6	6.76
Door casing (C) Room 2	1.1	1.4	1.25	1.5625
Baseboard Kitchen (D)	4.8	5.3	5.05	25.5025
Door (D) Room 1	6.3	7	6.65	44.2225
Add the ten squared averages together:		Quantity C		185.2925
Multiply Quantity C by 0.0072		Quantity D		1.334106
Add 0.032 to Quantity D:		Quantity E		1.366106
Take the square root of E:		Quantity F		1.16880537
Multiply Quantity F by 1.645:	Retest Tolerance Limit			<input type="text" value="1.9"/>
Compute average of all ten original XRF results				3.65
Compute average of all ten retest XRF results				3.9
Find the <i>absolute</i> difference of the two averages				<input type="text" value="0.25"/>



Most inspectors can conduct a LBP inspection of a small dwelling within one to two hours.

Time-and-Motion Study

The final method of evaluating the quality of a lead-based paint inspection is by conducting a simple time and motion analysis. Usually, inspections require at least one to two hours per unit (basic architectural details, two bedrooms, one bathroom) using existing technology. Additional time would be required if the housing unit or child-occupied facility is larger than that or has complex architectural details. Also, if the radioactive source has not been replaced within the last six to nine months, the time to conduct an inspection will increase. This is especially true if the lead levels in many of the surface coatings are close to the 1.0 mg/cm² standard. The inspector must enter a start and stop time on the data sheets and include that information in the final report. If start and stop times are missing from the data sheets provided or in the final report, this information should be requested from the inspector. If the inspector's on site time is significantly less than the time estimated, further investigation should be conducted to determine if the inspector actually completed the work in the report.

One or more of these four evaluation techniques should be used to monitor the quality of the inspection process and the final report. Which one(s) to use may depend upon several things:

- the client's familiarity with the inspecting firm;
- the level of knowledge/experience of the inspector(s);
- the number of units tested;
- the cost associated with each evaluation technique; and
- the amount of client oversight of the inspection (especially in multifamily housing).



Lead-based Paint Testing Operations

Preparation of Laboratory (Paint Chip) Samples

Should the XRF analysis values need confirmation with laboratory analysis, or if the surface relief of a component is not flat, it is the responsibility of the inspector to collect the paint chip samples for analysis by an accredited laboratory. Be sure to obtain the client's permission before conducting paint chip sampling. The client always has the option to *assume* that any coated surface contains lead-based paint, thereby avoiding destructive sampling.

The American Society of Testing and Materials (ASTM) has developed standards addressing the collection, preparation, and analysis of paint samples for lead determination.

ASTM standards include

- E 1729 Field Collection of Dried Paint Samples for Lead Determination
- E 1645 Preparation of Dried Paint Samples for Laboratory Analysis
- E 1613 Standard Test Method for Analysis of Digested Samples
- E1979-98 Standard Practice for Ultrasonic Extraction of Paint, Dust, Soil, and Air Samples for Subsequent Determination of Lead
- E1775-96 Standard Guide for Evaluating Performance of On-Site Extraction and Field-Portable Electrochemical or Spectrophotometric Analysis for Lead

These standards are available for purchase from ASTM (see the References section of this chapter).

Selecting the Area for Analysis

When examining a component for a location to collect a paint-chip sample, proper selection is essential. Spatial variation (how much the lead content changes across a given surface) on intact surfaces is known to be considerable. Across a surface with deteriorated paint, the variation may be even larger, since some areas may not contain all layers.

The inspector should make a visual inspection to select an area in which all layers of paint film are present and in which the least amount of deterioration is apparent. For destructive laboratory analysis, an unobtrusive area is typically selected, although it is more important to make sure that all layers are present.

ASTM and Appendix 13.2 of the *Guidelines* provide protocols by which to collect paint chip samples.



Inspecting for Lead-based Paint

Examples of unobtrusive areas include

- behind pictures
- behind furniture
- near corners
- underneath protruding surfaces (e.g., mantels, window sills).

Why Sampling All Paint Layers is Necessary

Several reasons to sample all layers include:

- The EPA work practice standards define an inspection as “a surface-by-surface investigation to determine the presence of lead-based paint.” Any paint that is not sampled or tested **must** be assumed to be lead-based paint.
- The information helps the owner plan future repair, remodeling, or renovations activity even if the layers with lead-based paint are now intact.
- The presence of deteriorated paint is an indication that other layers are more likely to fail in the near future.
- Repairing deteriorated layers will usually involve some abrasion of the intact layers below, possibly resulting in a lead-dust hazard.
- Different methods of paint analysis will be consistent only if all layers are analyzed (e.g., XRF, which measures all layers of a surface, may produce different results from laboratory paint chip analysis if the latter includes only some of the layers).

Always sample all layers of paint down to the substrate.

Sampling Materials

Appendix 13.2 of the HUD *Guidelines* describes the collection of paint chips as summarized in this section.

The following materials might be useful to prepare the samples:

- a sharp stainless steel paint scraper;
- a sharp, durable, cutting knife with a fine edge, thin scalpel blade, or a chisel;
- hard-shelled containers;
- labels;
- a permanent marker;
- metric tape measure or ruler (if results are to be reported in mg/cm²);





Lead-based Paint Testing Operations

- ladder;
- forms for recording data and chain-of-custody;
- disposable wipes for cleaning sampling tools (may also need a small container of mineral spirits or paint thinner to adequately clean scraper);
- disposable gloves (nonsterilized and nonpowdered);
- collection device (clean creased piece of paper or cleanable tray);
- plastic trash bags;
- flashlight;
- low-adhesive tape (e.g., blue painter's tape);
- a heat gun or other heat source operating below 1100°F to soften the paint before removal; and
- primer and filler to temporarily repair area sampled (if required).

Collecting the Sample

The first steps to prepare the sample container are listed below.

- On a data recording form identify the exact sampling location (including the room number, component name and number, exact address and unit number, client's name or project name, city, state and ZIP code).

Assign a unique sample number to each sample taken. This identification (ID) number will be on the sampling container when it goes to the laboratory for analysis. The same number must be recorded on the data recording form. This must be done carefully so that there is no uncertainty about the location and identify of each paint-chip sample. Make sure that no two samples have the same ID number.

- Record the sample number on the label and apply it to the outside of the plastic tube.

There are two containment methods recommended for avoiding contamination during paint chip sampling:

1. Place a clean sheet of plastic measuring four-by-four feet under the area to be sampled to capture any paint chips that are not captured by the collection device or creased piece of paper. Any visible paint chips falling to the plastic should be included in the sample. Dispose of the plastic after each sample is collected by placing the sheeting in a trash bag. Do not throw away the plastic at the dwelling. Premoistened wipes may be used to clean the area around and beneath the sample location.



Inspecting for Lead-based Paint

2. Loosely tape a durable plastic bag to the surface to be sampled, with a paint scraper, collection device, and shipment container housed inside the plastic. There should be enough "play" in the plastic to permit a scraping motion without dislodging the tape holding the plastic to the surface. *Slowly* remove the tape from the surface to avoid lifting any additional paint off of the surface. (Note: If using a heat gun to soften the paint, create a paper funnel with the bottom end sealed

A tray or other container should be held under the sampled surface to catch debris which falls. (The inspector will practice one of these containment methods in the hands-on portion of this course, but additional practice may be required to become proficient.)

The HUD *Guidelines* emphasizes the importance of collecting paint chip samples so that the dimensions of the surface area of paint removed can be measured accurately to within one-eighth of an inch. This allows the laboratory to report results in milligrams (mg) of lead per unit area (cm^2) versus weight percent or parts per million, allowing a direct comparison of XRF results to laboratory results. When results will be reported in mg/cm^2 , the inclusion of a small amount of substrate in the sample is permitted.

The inspector should remove the paint in a manner which minimizes the amount of substrate that is removed. If the surface area *cannot* be accurately measured, then this is especially critical since the weight of the substrate will "dilute" the percentage of lead of the total sample. The paint sample should be taken from a two- to four-square-inch area that is representative of the paint on the testing combination and is unobtrusive. (Check with the laboratory to which the sample will be sent to verify the minimum sample size they require.)

There are many different methods of collecting paint chips, including

- using pressure sensitive tape (to keep the paint film together) before cutting through all the layers of paint and then shaving the paint chip off with a chisel or paint scraper;
- cutting through all the paint layers with a razor, sharp knife, or chisel and then shaving the paint with a chisel or paint scraper;
- heating the area to be sampled with a heat gun (below 1100°F) to soften the paint before removal to lessen the chances of including substrate with the sample and to help prevent sample loss. This method utilizes the principle that paint and substrate materials heat and cool at different rates. It does not work well on plaster, works moderately well on concrete, and works very well on steel and wood. Care must be taken to avoid charring the paint or substrate. The paint should be scraped from the substrate as soon as the paint begins to soften or bubble.

If possible, accurately measure the dimensions of the surface sampled so the results can be reported in mg/cm^2 .

Check with the laboratory to determine minimum paint chip sample size.



Lead-based Paint Testing Operations

Whichever method is used, the following rules must always be followed:

- sample *all* layers of paint;
- avoid including the substrate in the sample (especially important if results will be reported in percent by weight or ppm);
- use care to contain the paint chip and any debris generated (especially important when using a heat gun since the forced air makes it difficult to contain small fragments of paint);
- use a brush, premoistened wipe, or minivacuum to clean the area and dispose of any residual material in a waste bag (*always* take any waste you generate with you—never dispose of it in the residence).

In the workshop portion of this course, each student will have the opportunity to collect a paint chip from a painted surface. With practice, an inspector can successfully remove the entire paint film down to, but not including, the substrate.

After using either method recheck to ensure that the samples are properly labeled for shipment to the laboratory. Place the sample into the corresponding prelabeled centrifuge tube or other rigid container and close the container. All of the sample must be placed in the container for shipment to the laboratory. A rigid container is used because the laboratory will analyze the entire sample submitted and nonrigid containers (e.g., plastic bags or paper envelopes) often make it difficult separate the entire sample from the container. Use a separate container to collect each sample.

Cleanup and Repair

All dust generated during the sampling procedure should be cleaned up using premoistened wipes or a small HEPA vacuum. The surface can be resealed with new paint if necessary. If desired, apply spackling and/or new paint to repair the area where paint was removed. If possible, the inspector should try to obtain paint or other coatings from the client in order to effect a better match and repair to the existing coating. Inspectors conducting paint sampling should avoid hand-to-mouth contact (specifically, smoking, eating, drinking, or applying cosmetics) and should wash their hands with running water immediately after sampling. The inspector should ask to use the resident's bathroom for this purpose. Premoistened wipes may be used if no running water is available or if the bathroom is not available.

Avoid including the substrate in the sample.

Clean up any debris using premoistened wipes or a small HEPA vacuum.



Flame AAS is the most common method for environmental lead sample analysis.

The *Guidelines* recommends collecting four square inches of paint.

Inspecting for Lead-based Paint

Laboratory Paint Chip Analysis

Paint chip analysis can be done using

- flame or graphite furnace atomic absorption spectroscopy (FAAS or GFAAS, respectively) or
- inductively coupled plasma emission spectroscopy (ICP-AES).

The laboratory can report the results of the lead level in either of two units:

- mg/cm^2

If results are to be reported in mg/cm^2 (as recommended in the *HUD Guidelines*), the area sampled *must be measured to one-eighth of an inch* (a small amount of substrate *can* be included in the sample for this method). The dimensions of the area sampled must be recorded on the field sampling form.

- $\mu\text{g}/\text{g}$, ppm, weight percent, or mg/kg

If results are reported using any of these units, the area sampled need not be measured exactly, but all layers must be included in the sample. Every effort must be made to exclude substrate in this method because including substrate material will increase the total weight and dilute the lead content. This is used if the surface area cannot be measured exactly.

For paint chip analysis, only one location on each testing combination needs to be sampled and measured.

For most laboratories, a sample of about two inches by two inches (or any other dimensions resulting in a total surface area of about four square inches) should produce enough paint for routine analysis by flame AA. Smaller sizes may be acceptable if graphite furnace AA, ICP-AES, or another, more sensitive method is used. Contact laboratories before beginning inspections to:

- determine minimum sample size required;
- alert them of when they will receive samples;
- determine how quickly they can return results to the inspector.



Lead-based Paint Testing Operations

Nonrecommended Methods of Paint Analysis

The following methods are not adequate for measuring lead in deteriorated paint films:

- **Portable XRF analysis of paint chips:** This method cannot be used since it is not possible to characterize the surface area exactly. Therefore, using a large number of small paint chips and spreading them out uniformly over a measured surface area will not produce a known surface area available for analysis.
- **Chemical spot test kits:** Although these kits hold some promise for the future, they are not recommended by EPA or HUD at this time (June 1999).

Chemical spot test kits are *not* recommended by EPA or HUD for paint-chip analysis.

Laboratories

All laboratories used by inspectors for paint film analysis must be recognized through one of the organizations in the EPA National Lead Laboratory Accreditation Program (NLLAP). At this time, two organizations have Memoranda of Understanding with EPA to evaluate and recognize laboratories

- American Association for Laboratory Accreditation (A2LA)
- American Industrial Hygiene Association (AIHA).

AIHA also administers the Environmental Lead Proficiency Analytical Testing (ELPAT) program. Laboratories cannot be used if they participate in ELPAT but are not willing to be NLLAP-recognized, or if they do not participate in either ELPAT or NLLAP.

Mobile Laboratories

Some new technologies have appeared which may make laboratory level accuracy and precision available in the field. These technologies include the portable anodic stripping voltametry (ASV) kits and laser technology. Should the organization or firm using these field technologies become NLLAP-recognized, they may be used by inspectors. Proper sample preparation and laboratory safety procedures are still required. More information on analytical methods for detecting lead in environmental samples can be found in Chapter 11, *Laboratory Analysis and Accreditation*.



Laboratory Submittal

The samples must be submitted to a laboratory recognized by the EPA National Lead Laboratory Accreditation Program (NLLAP). The Lead Listing is a service funded by HUD that can provide a list of NLLAP recognized laboratories (for contact information see the *References* section at the end of this chapter). Be certain that the samples are not mixed with dirt or soil. Do not put more than one sample in a single container. Several containers may be put into the same bag for storage purposes. Each container should be labeled as to the location where the samples were collected. If samples are mailed, use boxes, not envelopes, and enclose a cover letter to ensure that either the EPA 600/891/231 preparation procedure for hotplate or microwave-based acid digestion and atomic absorption spectrometry (AAS) or inductively coupled plasma atomic emission spectrometry (ICP-AES) is followed. ASTM also has developed a standard for sample preparation, E 1645 *Standard Practice for the Preparation of Dried Paint Samples for Subsequent Lead Analysis by Atomic Spectrometry*. Standard chain-of custody procedures should be used to ensure that the samples are traceable. Contact the laboratory *before* shipping samples for the first time. The laboratory may provide sampling supplies and forms. (See Chapter 11 for more information on sample analysis.)

Inspectors must submit paint samples to NLLAP-recognized laboratories.



Lead-based Paint Testing Operations

Review of Previous Paint Testing Results

If previous paint testing has been performed, the inspector should always review the report(s) to be sure the owner can rely on the data to determine which surfaces have lead-based paint and which do not. The sample checklist on the following pages can be used to review the paper report.

An inspector should always review any available reports of previous LBP testing.

Reviewing Paint Inspection Reports

Part One	Yes	No
1		
2		
3		
4		
5		
6		
7		
8		



Inspecting for Lead-based Paint

Part Two	Yes	No
9		
<p>Did the calibration checks indicate that the instrument was operating within the quality control value (see applicable <i>XRF Performance Characteristics Sheet (PCS)</i>)? Note: For inspections conducted before 1995, no PCSs were available.</p>		
10		
<p>Were the correct number of readings collected for each surface? Note: This answer to this question will depend on when the inspection was conducted and therefore, which version of the HUD <i>Guidelines</i> applied.</p>		
12		
<p>Were substrate corrections performed (if necessary)?</p>		
13		
<p>Were confirmatory paint chip samples collected for readings in the inconclusive range for the instrument used? (See the <i>PCS</i> for the instrument used.)</p>		
14		
<p>Was the procedure that was used to collect the paint chip samples described? If so, did it conform to the <i>Guidelines</i> (or for 1990-1995 testing, the <i>Interim Guidelines</i>)?</p>		
15		
<p>Was the laboratory that analyzed the paint samples identified?</p>		
16		
<p>Was the laboratory that analyzed the paint samples NLLAP recognized? If the samples were collected pre-NLLAP, was the lab ELPAT proficient?</p>		

If the review shows that testing may have been unreliable, the inspector should recommend some type of repeated or supplemental testing, depending on the results of the review. For example, if no substrate correction was performed but should have been, the inspector should recommend that substrate correction readings be made and results of the inspection recalculated.

Sources of potential error in paint film analysis include

- Measuring or sampling a spot where paint deterioration is such that the lead layer has fallen off or been removed by previous repainting jobs;
- Including the substrate in weight percent analysis;
- Failing to measure the surface area of the paint film to within one-eighth of an inch;



Lead-based Paint Testing Operations

- Non-quantitative transfer (e.g., use of plastic sealable bags instead of hard-shelled containers, such as 50 ml nonsterilized but clean polypropylene centrifuge tubes when results are desired in percent by weight);
- Failure to include all layers in the sample;
- Failure to notify the laboratory that the results must be reported in total μg of lead/sample, as well as mg/cm^2 .



It is important to keep detailed records of an inspection.

The summary report of a LBP inspection should answer two questions:

Is there lead-based paint in the property?

If so, where is it located?

Inspecting for Lead-based Paint

Recordkeeping

One of the major responsibilities of the inspector is to keep detailed records. Chapter 7 of the *HUD Guidelines* contains a complete set of sample forms which are to be filled out during the inspection process. Research conducted by HUD on the quality of lead-based paint inspections indicates that some inspectors provide reports that are incomplete, inaccurate, and sometimes incomprehensible, whether reviewed by another certified inspector or risk assessor or by the property or home owner.

Two possible methods of data documentation are recommended. One method for recording XRF readings is on handwritten forms, such as the complete set of forms provided in the *HUD Guidelines* or comparable forms. Handwritten data collection can result in transcription errors; therefore, handwritten forms should be examined for missing data and copying errors. The other method of data collection is electronic storage. This method is recommended only if sufficient data are recorded to allow another person to find the test location that corresponds to each XRF reading. Caution should be exercised when using electronic data collection due to potential loss of data. The *Guidelines* recommend examining on a daily basis "hard-copy" listings of the electronically stored data for extraneous symbols or missing data, including missing test location identification.

A summary report that answers two questions should be provided to the client:

1. Is there lead-based paint in the property?
2. If lead-based paint is present, where is it located?

The summary report should also include:

- the property address where the inspection was performed;
- the date(s) of the inspection;
- the name of the inspector and inspection company and any appropriate licenses or certification numbers;
- the manufacturer, model number, and serial number of the XRF analyzer(s) used; and
- the starting and ending times for each day when XRF testing was done.

Detailed documentation of the XRF testing should also be provided in the full report, including the raw data and quality assurance data. The single-family and multifamily housing forms provided at the end of this chapter, or comparable forms completed by the inspector, would serve this purpose. Additional information on recordkeeping and the final report are included in Chapter 14.



Lead-based Paint Testing Operations

For More Information

These publications and organizations can provide more information on the topics covered in this chapter.

The Guidelines for the Evaluation and Control of Lead-based Paint Hazards in Housing, 1995 (rev. 1997), U.S. Department of Housing and Urban Development.

Lead; Requirements for Lead-Based Paint Activities in Target Housing and Child-Occupied Facilities; Final Rule, 40 CFR Part 745, U.S. Environmental Protection Agency, 1996.

Inspecting for Lead-based Paint, model curriculum, U.S. Environmental Protection Agency, 2nd edition, 1999.

Federal agencies

Consumer Product Safety Commission (CPSC)
 Washington, DC 20207-0001
 800-638-2772
 Website: www.cpsc.gov

Department of Housing and Urban Development (HUD)
 Office of Lead Hazard Control
 451 7th Street, S.W.
 Washington, DC 20410
 202-755-1785
 Website: www.hud.gov/lea

Department of Labor
 Occupational Safety and Health Administration (OSHA)
 200 Constitution Avenue, N.W.
 Washington, DC 20210
 202-693-2000
 Website: www.osha.gov

Environmental Protection Agency (EPA)
 Office of Pollution Prevention and Toxics
 401 M Street, S.W.
 Washington, DC 20460-0003
 202-260-2090
 Website: www.epa.gov/lead

Non-governmental organizations

American Association for Laboratory Accreditation (A2LA)
 5301 Buckeystown Pike, Suite 350
 Frederick, Maryland 21704
 Telephone: 301-644-3248
 Website: www.a2la.org

There are many federal, state, tribal, and local agencies and private organizations that can provide additional information on lead.



Inspecting for Lead-based Paint

American Industrial Hygiene Association (AIHA)
 2700 Prosperity Ave., Suite 250
 Fairfax, Virginia 22031
 Telephone: 703-849-8888
 Website: www.aiha.org/lead.html

American Society for Testing and Materials (ASTM)
 100 Barr Harbor Drive
 West Conshohocken, Pennsylvania, 19428-2959
 Web site: www.astm.org

National Conference of State Legislatures (NCSL)

Denver Office:	Washington Office:
1560 Broadway, Suite 700	444 North Capitol St, N.W., Suite 515
Denver, CO 80202	Washington, D.C. 20001
Tel: 303-830-2200	Tel: 202-624-5400
Fax: 303-863-8003	Fax: 202-737-1069
Website: www.ncsl.org	

National Lead Assessment and Abatement Council (NLAAC)
 P.O. Box 535
 Olney, Maryland 20830
 800-590-6522

National Lead Information Center Hotline
 800-424-LEAD
 Website: www.epa.gov/opptintr/lead/nlic.htm

The Lead Listing
 888-LEADLIST
 Website: www.leadlisting.org

Lead-based Paint Testing Operations



Appendix A



Inspecting for Lead-based Paint

Lead-based Paint Testing Operations

Substrate Correction Values Form

Page ____ of ____

Address/Unit No. _____

Date: _____ XRF Serial No. _____

Inspector's name _____ Signature _____

Use this form when the *XRF Performance Characteristics Sheet* indicates that correction for substrate bias is needed.

Substrate		Brick	Concrete	Drywall	Metal	Plaster	Wood
L O C A T I O N	1	First Reading					
		Second Reading					
		Third Reading					
	2	First Reading					
		Second Reading					
		Third Reading					
Correction Value (Average of the Six Readings)							
Subtract NIST Standard*							
Final Substrate Correction Value							

*The requirement to use the NIST standard closest to 1.0 mg/cm² will be stated in the *PCS* for the XRF analyzer. Transfer the Final Substrate Correction Value for each substrate to the 'Correction Value' column of the LBP Testing Data Sheet.

Notes:

Inspecting for Lead-based Paint

Lead-based Paint Testing Operations

Single-family Housing LBP Testing Data Sheet

Page ____ of ____

Address/Unit No. _____

Date _____

Room Equivalent _____

XRF Serial No. _____

Inspector Signature _____

Sample ID#	Substrate	Component	Color	Test Locations	XRF Reading	Correction Value	Result	Classification (pos.neg.inc)	Laboratory Result	UNIT?	Final Classification
										mg/cm ²	
										%	
										mg/cm ²	
										%	
										mg/cm ²	
										%	
										mg/cm ²	
										%	
										mg/cm ²	
										%	
										mg/cm ²	
										%	
										mg/cm ²	
										%	
										mg/cm ²	
										%	
										mg/cm ²	
										%	
										mg/cm ²	
										%	
										mg/cm ²	
										%	
										mg/cm ²	
										%	
										mg/cm ²	
										%	
										mg/cm ²	
										%	
										mg/cm ²	
										%	
										mg/cm ²	
										%	
										mg/cm ²	
										%	
										mg/cm ²	
										%	
										mg/cm ²	
										%	
										mg/cm ²	
										%	
										mg/cm ²	
										%	
										mg/cm ²	
										%	
										mg/cm ²	
										%	
										mg/cm ²	
										%	
										mg/cm ²	
										%	
										mg/cm ²	
										%	
										mg/cm ²	
										%	
										mg/cm ²	
										%	
										mg/cm ²	
										%	
										mg/cm ²	
										%	
										mg/cm ²	
										%	
										mg/cm ²	
										%	
										mg/cm ²	
										%	
										mg/cm ²	
										%	
										mg/cm ²	
										%	
										mg/cm ²	
										%	
										mg/cm ²	
										%	
										mg/cm ²	
										%	
										mg/cm ²	
										%	
										mg/cm ²	
										%	
										mg/cm ²	
										%	
										mg/cm ²	
										%	
										mg/cm ²	
										%	
										mg/cm ²	
										%	
										mg/cm ²	
										%	
										mg/cm ²	
										%	
										mg/cm ²	
										%	
										mg/cm ²	
										%	
										mg/cm ²	
										%	
										mg/cm ²	
										%	
										mg/cm ²	
										%	
										mg/cm ²	
										%	
										mg/cm ²	
										%	
										mg/cm ²	
										%	
										mg/cm ²	
										%	
										mg/cm ²	
										%	
										mg/cm ²	
										%	
										mg/cm ²	
										%	
										mg/cm ²	
										%	
										mg/cm ²	
										%	
										mg/cm ²	
										%	
										mg/cm ²	
										%	
										mg/cm ²	
										%	
										mg/cm ²	
										%	
										mg/cm ²	
										%	
										mg/cm ²	
										%	
										mg/cm ²	
										%	
										mg/cm ²	
										%	
										mg/cm ²	
										%	
										mg/cm ²	
										%	
										mg/cm ²	
										%	
										mg/cm ²	
										%	
										mg/cm ²	
										%	
										mg/cm ²	
										%	
										mg/cm ²	
										%	
										mg/cm ²	
										%	
										mg/cm ²	
										%	
										mg/cm ²	
										%	
										mg/cm ²	
										%	
										mg/cm ²	
										%	
										mg/cm ²	
										%	
										mg/cm ²	
										%	
										mg/cm ²	
										%	
										mg/cm ²	
										%	
										mg/cm ²	
										%	
										mg/cm ²	
										%	
										mg/cm ²	
										%	
										mg/cm ²	
										%	
										mg/cm ²	
										%	
										mg/cm ²	
										%	
										mg/cm ²	
										%	
										mg/cm ²	
										%	
										mg/cm ²	
										%	
										mg/cm ²	
										%	
										mg/cm ²	
										%	
										mg/cm ²	
										%	
										mg/cm ²	
										%	
										mg/cm ²	
										%	
										mg/cm ²	
										%	
										mg/cm ²	
										%	
										mg/cm ²	
										%	
										mg/cm ²	
										%	

Inspecting for Lead-based Paint

Inspecting for Lead-based Paint

Inspecting for Lead-based Paint



Inspecting for Lead-based Paint





Lead-based Paint Testing Operations

Field Sampling Form for Paint (One form for each housing unit, common area, or exterior)

Name of property owner _____ Page ____ of ____

Property address _____ Apt. no. _____

Name of inspector _____ Signature _____

Sample Number	Room Equivalent	Building Component	Area Sampled* (to 1/8" inch)	Units?
				mg/cm ² %
				mg/cm ² %
				mg/cm ² %
				mg/cm ² %
				mg/cm ² %
				mg/cm ² %
				mg/cm ² %
				mg/cm ² %
				mg/cm ² %
				mg/cm ² %

*Applicable when results will be reported in mg/cm².

Federal standard 5,000 µg/g or 1.0 mg/cm²

Sample all layers of paint, not just deteriorated paint layers.

Total number of samples this page _____

Date of sample collection ____/____/____ Date shipped to lab ____/____/____

Relinquished by _____ Received by _____
(signature) (signature)

Relinquished by _____ Received by _____
(signature) (signature)

Date results reported ____/____/____



Inspecting for Lead-based Paint



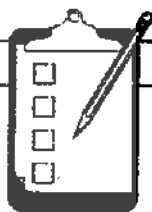

CHAPTER 8

VISUAL INSPECTIONS

Objective	8-3
Learning Tasks	8-3
Final Cleanup	8-4
Visual Inspections	8-5
Lead Hazard Control Visual Clearance Form	8-9



Inspecting for Lead-based Paint





Visual Inspections

Objective

The objectives of this chapter are to

- explain the importance of the final visual inspection in the lead hazard control project;
- detail the specific steps in a visual inspection.

Learning Tasks

After completing this chapter, inspectors should be able to

- list specific areas of concern to an inspector based upon the hazard control strategy implemented;
- document the results of a visual inspection on the appropriate form.



Children are extremely vulnerable to lead in dust.

Postabatement visual inspections and clearance dust sampling are required by EPA in target housing and child-occupied facilities.

There are two stages to the final inspection: visual inspection, and environmental sampling.

Final Cleanup

Because small children frequently put their fingers in their mouths, they are extremely vulnerable to lead in household dust. Because of the small particle size, lead in dust is also easily absorbed into the blood once ingested. Therefore, there is great concern that improper abatement of lead-based paint may add large amounts of leaded dust to the environment. In the past, little attention was paid to the importance of cleaning up dust after lead-based paint abatement. In some cases, abatement had the tragic result of actually causing lead poisoning in children because of the inadequacy of cleanup. The typical cleanup of a construction job in which the site is left in "broom clean" condition is totally inadequate following lead-based paint abatement and will often aggravate the problem by spreading dust.

The concern with postabatement dust lead levels caused HUD to establish stringent guidelines for cleanup after abatement and for clearance testing following cleanup. EPA's final work practice standards for conducting lead-based paint activities in target housing and child-occupied facilities include a requirement for postabatement visual inspections and clearance dust sampling. Special cleanup procedures involving high efficiency particle air (HEPA) vacuuming and all-purpose cleaning agents are recommended.

Final cleanup generally involves painting and sealing of abated surfaces, including all floors (whether abated or not), followed by a second HEPA/wet wash/HEPA cycle, if necessary. Final cleanup should not begin until all hazard control work has been completed and after waiting at least one hour. In addition, a final visual inspection should not be conducted until *at least one hour* after final cleanup has been completed.

To ensure the effectiveness of the cleanup, the inspector has three responsibilities:

- visual inspection;
- clearance testing of dust, and
- visual examination of soil (or postabatement soil sampling [optional]), if applicable.

This chapter addresses visual inspections associated with clearance. Chapter 9 addresses dust sampling and Chapter 10 addresses soil sampling.



Visual Inspections

Visual Inspections

A visual inspection determines whether the work on all interior and exterior surfaces to be treated was in fact completed and to ensure that no visible settled dust or debris are present. The inspector should have access to any risk assessment or paint inspection reports as well as the job scope of work or specifications in order to determine the work was completed as specified.

The inspector should pay special attention to the following potential problem areas:

- areas where lead paint has been removed adjacent to intact paint

An example is where paint is removed from a door frame but not from the adjacent wall. The boundary between the abated and unabated areas must be sound.

- windows

These should be checked for paint in hard-to-reach areas, especially sills, thresholds, the tops of parting bead areas, and under the lips of window sills.

- sealing and repainting

All abated areas should be repainted or otherwise sealed.

When paint removal and repainting or soil removal and covering is planned, verification of the removal of the lead hazards will be necessary prior to the completion of work (i.e., an inspector must visually determine that the lead-based paint was removed prior to the contractor repainting those surfaces). This will usually require two separate trips by the inspector to the job site—one to visually inspect the surfaces treated, and another to conduct clearance dust sampling after repainting and final cleanup. It is important to explain these steps to the client and the contractor to reduce the likelihood that a project will progress past the stage at which a visual inspection should have been conducted before the inspector is notified.

The inspector's focus for the visual examination will differ depending on the hazard control strategy implemented during the project.

Paint removal and repainting

The inspector should examine all surfaces where paint has been removed *prior to repainting*. If clearance is conducted after new paint is applied, it is often impossible to determine if the old paint was actually removed. Areas commonly overlooked during paint removal projects include the

- underside of interior window sills and handrails,

The inspector performs a visual inspection to determine that the control strategy exactly followed the hazard control plan.

Visual inspections require an understanding of the scope of the job and a keen eye for detail.

Make sure the client understands when the visual inspection occurs in the hazard control process.



The visual examination should focus on hard to reach areas.

Inspecting for Lead-based Paint

- backside of interior window sills and handrails,
- backside of radiator ribs,
- bottom edge of doors,
- top of door frames, and
- back edge of shelving.

For both onsite and offsite removal, the inspector should examine the bare surfaces to ensure that no visible residue remains.

Building component removal and replacement

If building components coated with lead-based paint were removed as a lead hazard control measure, the clearance inspector should have detailed knowledge of the scope of the replacement activities so that the actual removal can be verified.

When component removal and replacement is specified, it is possible that the hazard control contractor will only remove the components coated with lead-based paint, and a separate renovation contractor will install the replacement components after the project has passed clearance. In that case, the inspector documents that the specific components were removed. Generally, the owner's or architect's representative will document that the replacement components were installed as specified.

Enclosures

Complete installation of enclosure systems, such as new drywall, paneling, or siding, can be best evaluated by direct visual observation. The inspector should determine that the mechanical fastening system used to hold the enclosure to the substrate is adequate. All seams and edges in the enclosure should be sealed to provide a "dust-tight," but not necessarily airtight, system. Depending on the level of the inspector's involvement in the hazard control project, an inspector may not be hired to monitor installation, but only to evaluate that the enclosure was installed on the appropriate surfaces.

On some projects involving encapsulants, an inspector may be asked (set forth in the contract) to return several months later to check the integrity of the encapsulants.

Encapsulants

Another category of lead hazard control that can best be assessed visually is the application of encapsulants. Again, depending on the inspector's level of involvement, a visual inspection may only include

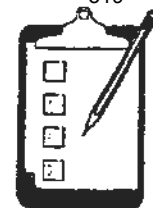

Visual Inspections

documenting that the specified surfaces were encapsulated. Unless the inspector is present during the application of the encapsulant and any "patch tests" that were conducted, the inspector should clearly state that he/she cannot attest to the application, but merely that the encapsulant was applied to the correct surfaces.

Interim controls

Visual examination of the wide variety of interim control measures consists of a confirmation that all lead-based paint (either suspected or identified through testing) is stabilized and that any friction, impact, and other surfaces marked for treatment in the project specifications have been properly treated. No known or suspected lead-based paint should be in a deteriorated condition in a dwelling that has passed the visual inspection. Some interim controls are followed by dust sampling to document that cleanup was accomplished properly.

Soil treatments

Soil treatments, which typically consist of some form of covering or removal and replacement, also be assessed by direct visual observation to determine if the covering is present. For example, if sod or asphalt has been used as a soil covering, the inspector should determine if all bare areas have been covered by the sod or asphalt, as specified.

No visible lead-based paint chips should be observed in soil following lead hazard control work. It is not necessary to turn over or rake soil to look for paint chips. A visual examination of the surface is adequate.

Visual examination for settled dust and debris

There should be no evidence of settled dust following a cleanup effort. If dust is observed, the contractor must be required to repeat the cleaning effort *before* clearance dust samples are collected. Any settled dust present following abatement or interim control work provides sufficient evidence that cleanup was not adequate.

The grounds around the dwelling and all exterior horizontal surfaces should also be examined visually to make certain that all waste and debris have been removed and that leaded dust or paint chips were not transferred outside the dwelling. The inspector should be particularly conscientious about looking for paint chips when exterior components have been disturbed.

If the results of the visual inspection are unsatisfactory, further lead hazard controls must be performed as necessary and/or surfaces must be recleaned until satisfactory results are achieved. Visual inspection

Interim control measures should always be followed up by a visual inspection for dust and debris.

If a work area fails the visual inspection, the contractor must complete the hazard controls and/or reclean before dust samples are collected.



Inspecting for Lead-based Paint

results should be carefully documented and a copy provided to the contractor, the client, and maintained in the inspector's project files. A sample form, *Lead Hazard Control Visual Clearance Form*, is included at the end of this chapter.

Clearance after renovation or rehabilitation work

A visual examination is also required at the end of many renovation and rehabilitation projects in federally-owned or assisted housing if the project will disturb painted surfaces. This examination includes a visual examination of all painted surfaces for evidence of defective or deteriorated paint. The renovation or rehab contractor must pass the visual examination before clearance dust sampling is conducted. Once the dwelling has passed the clearance standards, the clearance examiner must prepare a clearance report (24 CFR Part 35.1340) documenting passage.



Inspecting for Lead-based Paint





CHAPTER 9

DUST SAMPLING FOR LEAD CONTAMINATION

Objectives	9-3
Learning Tasks	9-4
Importance of Dust as an Exposure Pathway	9-5
Sources of Lead in Dust	9-7
Units of Measure	9-8
Clearance dust levels	9-9
Wipe Sampling Protocol	9-12
Wipe Sampling Materials and Supplies	9-13
Single-surface Wipe Sampling Procedure	9-15
Composite Wipe Sampling	9-19
Blank Preparation	9-21
Inspector Decontamination	9-22
Spiked Sample Submission	9-23
Quality Assurance/Quality Control	9-24
Advantages and Disadvantages of Composite Wipe Sampling	9-25
When to Use Single-surface and Composite Wipe Samples	9-26
Avoiding Cross-sample Contamination	9-27
Sampling Data Forms	9-28
Number and Location of Wipe Samples	9-29
Sampling after Routine Maintenance Work	9-33
Interpretation of Test Results	9-34
Sample Dust Sampling Forms	9-37



Inspecting for Lead-based Paint





Dust Sampling for Lead Contamination

Objectives

The objectives of this chapter are to

- provide inspectors with information on sources of lead in dust;
- show in detail how inspectors should conduct testing for pre- and post remediation dust sampling;
- define the EPA and HUD levels of lead in dust for identifying lead-based paint hazards.



Learning Tasks

After completing this chapter, inspectors should be able to

- evaluate the different sources of lead-contaminated dust in a dwelling;
- conduct pre- and postabatement clearance dust sampling and interpret the results;
- describe differences between single-surface wipe sampling and composite wipe sampling;
- understand the importance of quality assurance and quality control when conducting wipe sampling.

This section is important to you as an inspector because

- different sampling and testing procedures are needed for dust than those used for lead-based paint.



Dust Sampling for Lead Contamination

Importance of Dust as an Exposure Pathway

A number of studies have shown that dust is an important (but not the only) pathway of exposure to lead. Recently, studies have shown that dust lead levels are the strongest predictor of children's blood lead levels compared with a number of other variables. Proper measurement of dust lead levels is therefore essential to the risk assessment process.

Some owners may question the usefulness of dust samples and whether or not it is really necessary to collect and analyze them. Owners may want proof that scientific research supports the importance of dust. A few research studies are listed below.

- The contribution of lead-contaminated house dust and residential soil to children's blood lead levels, *Environmental Research*; 79(1):51-68, October 1998.
- Lead-contaminated house dust and urban children's blood lead levels, Lanphear, Weitzman, Winter, Tanner, Yakir, Eberly, Emond, Matte. *American Journal of Public Health*, 86:1416-1421, 1996.
- The longer-term effectiveness of residential lead paint abatement, Farfel et al., *Environmental Research* 66, 217-221, 1994.
- Childhood exposure to lead in surface dust and soil: A community health problem, Duggan and Inskip, *Public Health Review* 13, 1-54, 1985.
- Childhood lead poisoning: A controlled trial of dust control measures on blood lead levels, Charney et al., *New England Journal of Medicine* 309 (18), 1089-93, 1983.
- Environmental correlates of infant blood lead levels in Boston, Rabinowitz et al., *Environmental Research* 38, 96-107, 1985.
- Exterior surface dust lead, interior house dust lead and childhood lead exposure in an urban environment, Bornschein et al., in *Trace Substances in Environmental Health II*, D. D. Hemphill, University of Missouri, Columbia, 1986.
- Urban lead exposures of children in Cincinnati, Ohio, Clark et al., *Chemical Speciation and Bioavailability* 3 (3/4), 163-171, 1991.
- *Does residential lead-based paint hazard control work? A review of the scientific evidence*, Catherine Staes and Richard Reinhart, National Center for Lead-safe Housing, Columbia, Maryland, 4 April 1995.

Studies have shown that dust lead levels are a strong predictor of children's blood lead levels.



As an example, the Cincinnati study has validated the following model:

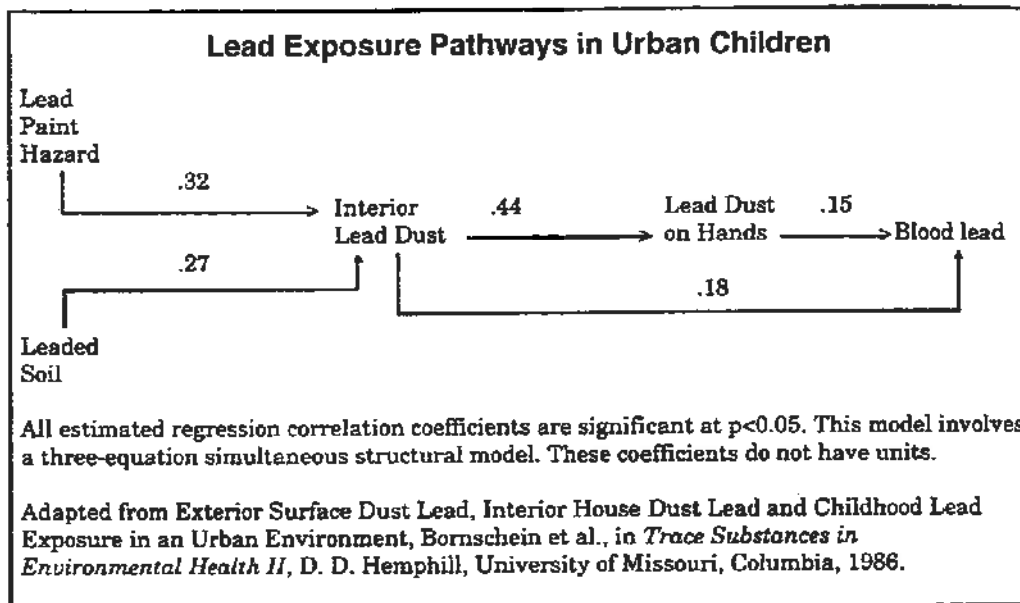

This model demonstrates that there is a statistically significant relationship between lead-based paint and lead-contaminated soil with interior house dust. The house dust can be shown to be significantly related to both hand lead dust and directly to blood lead level. Finally, the lead dust levels measured on children's hands can also be significantly correlated with children's blood lead levels. The most plausible explanation is that children ingest settled leaded dust through normal hand-to-mouth activity.



Dust Sampling for Lead Contamination

Sources of Lead in Dust

Lead is commonly found in interior house dust, with the primary source being lead-based paint. In a 1990 survey of lead-based paint in privately owned housing, the U.S. Department of Housing and Urban Development (HUD) found that houses with lead-based paint were much more likely to have high levels of lead in dust than houses with no lead-based paint.¹ However, there are other sources of lead in dust, primarily from people and pets tracking dust and dirt into the house from outdoors.

The most likely place for the inspector to find lead in house dust is on window sills and in window troughs. There are several reasons for this. First, lead-based paint was often used on both wood and metal windows because of its durability. Second, repeated opening and closing of windows tends to damage the paint and produce leaded dust if the paint contains lead. Third, dust accumulates on window troughs since they are cleaned very infrequently. Recent studies have determined that lead dust on window sills and floor are a better predictor of children's blood lead levels than lead dust on window troughs.

Lead can be found in dust on floors, especially near windows, doors, or baseboards that are painted with lead-based paint. Leaded dust is also common near exterior doorways, reflecting tracking of dust and soil from outdoors by people and animals. Furthermore, lead can be found in sidewalk dust near homes with exterior lead-based paint. Such paint was designed to weather or "chalk," which results in a continuing source of lead contaminating soil and dust. Historically, lead in gasoline was also a major source of lead in soil and exterior dust. Finally, high levels of lead have been found in attic dusts in houses near smelters, battery plants, and other industrial sources of airborne lead emissions.

Interior dust lead levels can be reduced by conscientious housekeeping, especially regular cleaning of floors, window sills, and window troughs. Wet mopping and wiping on a regular basis are particularly effective activities to control accessible dust. However, lead dust reaccumulation rates are likely to be rapid if paint is in poor condition or if renovation is underway. Note that ordinary vacuuming of dust known or suspected to contain lead should not be used as a cleaning method. Rather, only vacuums equipped with a HEPA filter should be used.

Inadequate cleanup after an abatement project has caused lead poisoning of children.

US Department of Housing and Urban Development, *Comprehensive and Workable Plan for the Abatement of Lead-based Paint in Privately-Owned Housing: A Report to Congress*, 1990.



Units of Measure

There are two ways to describe the amount of lead in dust:

- loading (area concentration) ($\mu\text{g}/\text{ft}^2$ or $\mu\text{g}/\text{cm}^2$);
- mass concentration ($\mu\text{g}/\text{g}$, ppm, or mg/kg).

Loading is a measure of the total amount of lead present in micrograms of lead per square foot of surface area. Weight concentration is a measure of the amount of lead contained in dust, expressed in micrograms of lead per gram of dust ($\mu\text{g}/\text{g}$). These two units are not interchangeable and cannot be converted into the other on a routine basis; however, the two units of measure are often highly correlated. Loading can be reduced by cleaning while concentration may not.

Loading is measured directly by wipe sampling or vacuum sampling. Concentration is usually measured by vacuum sampling and cannot be measured by the standard wipe sampling methods taught in this course.

Wipe sampling is the recommended method for clearance dust-wipe sampling for the following reasons:

- it is relatively simple and inexpensive;
- it has been correlated with children's blood lead levels in a number of studies;
- current EPA, HUD, and state standards are based on wipe sampling;
- vacuum sampling methods are not standardized;
- since there are no concentration standards, it is not possible to identify dust hazards directly using vacuum sampling.



Dust Sampling for Lead Contamination

Clearance dust levels

EPA has the task of developing a health-based standard defining lead-dust hazards. Until these standards have been developed, the following guidance levels, issued by EPA in interim guidance (July 1994), should be used:

Surface	Dust lead level ($\mu\text{g}/\text{ft}^2$) (as determined by wipe sampling)
Floors	100
Interior window sills (stools)	500
Window troughs (wells) and exterior surfaces	800

Note: Some states may have different levels; inspectors may need to evaluate results based on the local, state, or federal standard, whichever is most stringent.

Effective 15 September 2000, the following levels will apply in federal-owned or assisted housing (as established by 24 CFR part 35—*Requirements for Notification, Evaluation and Reduction of Lead-based Paint Hazards in Housing Receiving Federal Assistance and Federally-Owned Residential Property Being Sold*):

Surface	Dust lead level ($\mu\text{g}/\text{ft}^2$) (as determined by wipe sampling)
Floors	40
Interior window sills (stools)	250
Window troughs (wells) and exterior surfaces	800

Note: Some states may have different levels; inspectors may need to evaluate results based on the local, state, or federal standard, whichever is most stringent.

The levels established by HUD will remain in effect in federally-owned or assisted housing until EPA issues the final lead-contaminated dust standards. At that time, the EPA levels will become the standard for all types of housing and child-occupied facilities. Therefore, the inspector must determine which standards apply to the housing before conducting clearance evaluations.

EPA has established interim lead-dust levels for floors, windows sills, and window troughs.

HUD's clearance levels remain in effect only until EPA issues final dust - lead standards.

The clearance levels for lead in dust are for specific surfaces. The terms used to describe these surfaces are defined as follows:

- Interior window sills—The portion of the horizontal window ledge that protrudes into the interior of the room, adjacent to the window sash when closed; technically called the window “stool.”
- Window trough—The portion of the horizontal window sill that receives both the upper and lower window sashes when they are both lowered, often located between the storm window and the interior window sash; sometimes called the window well. If there is no storm window, the window trough consists of the portion of horizontal window trim that contacts the sash(es) when they are closed (i.e., not the entire exterior sill). If there is only one sash, use the part of the window sill contacted by the sash when closed. See Figure 9-1 for an illustration of the window surfaces from which dust samples should be collected.
- Bare floors
- Carpeted floors (if present)
- Exterior hard surfaces

How much dust is this? Take a packet of coffee sweetener, which weighs 1 gram. If you were to spread this over 100 rooms, each measuring 10 feet by 10 feet, you would have:

$$100 \text{ rooms} \times 10 \text{ ft} \times 10 \text{ ft} = 10,000 \text{ ft}^2$$

Since 1 gram = 1 million micrograms:

$$\frac{1,000,000 \text{ } \mu\text{g}}{10,000 \text{ ft}^2} = 100 \text{ } \mu\text{g}/\text{ft}^2$$

This means that we are interested in picking up only a few grains within a one square foot area. These grains may be invisible to the naked eye; thus, careful and complete sampling is needed.

Dust measurements cannot be made with the naked eye. For example, if the packet of coffee sweetener had a concentration of 100 $\mu\text{g}/\text{g}$ of lead and was spread over a 1 square foot area, the lead loading would be 100 $\mu\text{g}/\text{ft}^2$. However, if the coffee sweetener had a lead concentration of 1,000 $\mu\text{g}/\text{g}$, then only 1/10 of the packet spread over the surface would yield the same 100 $\mu\text{g}/\text{ft}^2$. The surface looks dustier in the first example than in the second, but the loading is exactly the same. The lead available to children is also the same. Therefore, measuring loading is always important. Relying on visual appearance alone will be inadequate.

Because of the small amounts involved, measuring carefully and exactly (to within 1/8 of an inch) the surface area wiped is absolutely necessary.



Figure 9-1
Window Locations for Dust Sampling

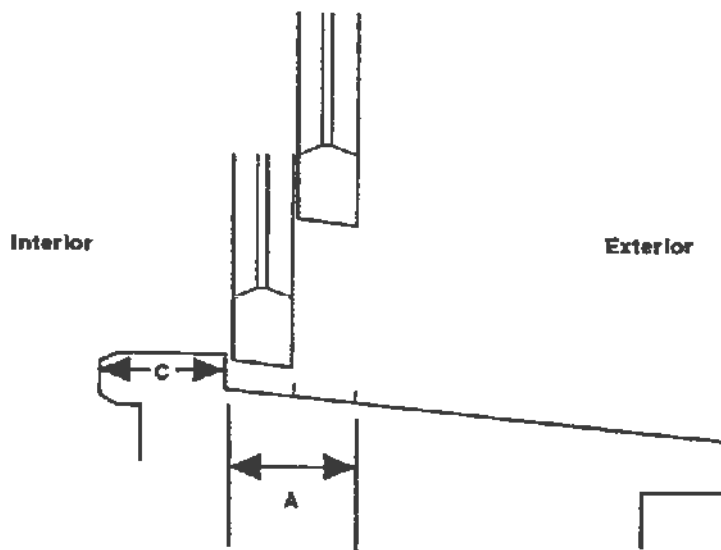

1. Side view of window (with no storm window) showing window trough area, A, to be tested. Trough is strip across window sill where interior window sashes can touch the sill. The interior window sill is shown as area C. Interior window sills and window troughs should be sampled separately.

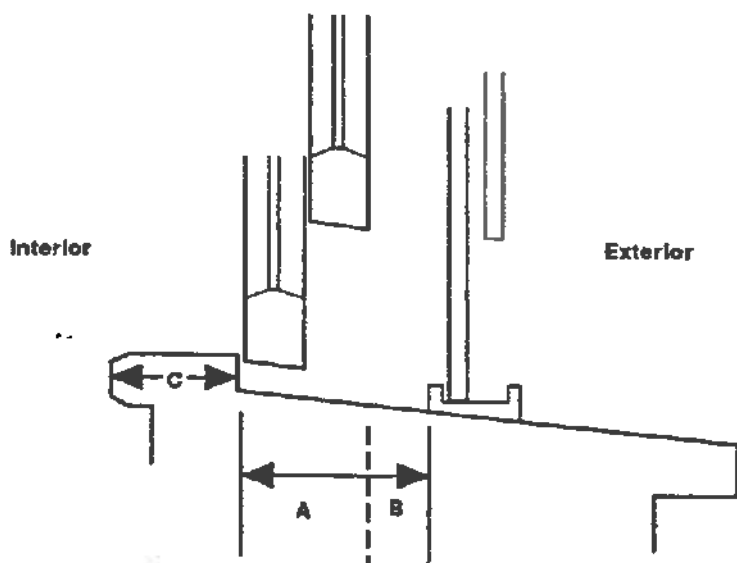

2. Side view of window (including storm window) showing window trough area, A and B, to be tested. Trough extends out to storm window frame. The interior window sill is shown as area C. Interior window sills and window troughs should be sampled separately.

Wipe Sampling Protocol

Although other wipe sampling methods have been developed, this course teaches the wipe sampling protocols described by HUD, EPA, and the American Society for Testing and Materials (ASTM) (ASTM E 1728). These protocols must be followed by inspectors because the current standards were developed using only these methods.

The methods will be described and then demonstrated. In the practicum part of this course, an instructor will determine your proficiency in doing the wipe sampling. While the wipe sampling method is relatively easy, many students initially fail the practicum because they fail to exercise adequate care.

Wipe samples for settled lead dust can be collected from floors (both carpeted and uncarpeted); interior window sills and window troughs; and exterior surfaces which might be contaminated during the hazard control activities. Wipe media should be sufficiently durable so that they are not easily torn but nevertheless can be easily digested in the laboratory. Recovery rates of between 80 to 120 percent of the true value should be obtained for all media used for wipe sampling. Blank media should contain no more than 5 $\mu\text{g}/\text{wipe}$.

Wipe samples are collected from floors, interior window sills, and window troughs.

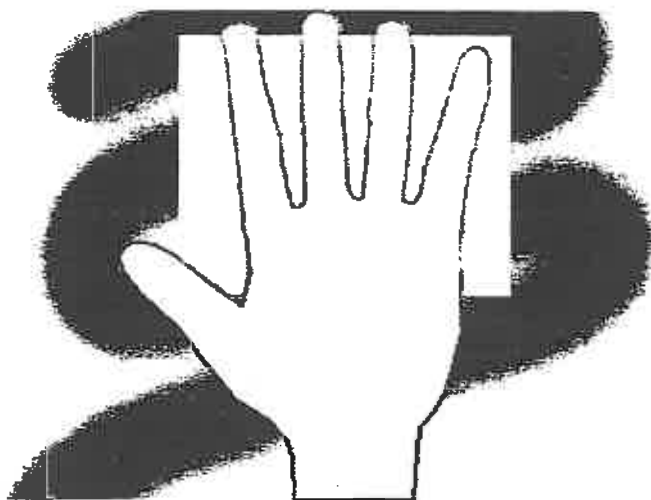



Dust Sampling for Lead Contamination

Wipe Sampling Materials and Supplies

Type of Disposable Wipe

Any wipe material that meets the following criteria may be used:

- contains low background lead levels (less than 5 µg/wipe);
- is a single thickness;
- is durable and does not tear easily (do not use Whatman™ filters);
- does not contain aloe;
- can be digested in the laboratory;
- has been shown to yield 80 to 120 percent recovery rates from samples spiked with lead dust (not lead in solution);
- remains moist during the wipe sampling process (wipes containing alcohol may be used as long as they do not dry out).

The inspector should send two to three wipes from each lot number of wipes purchased to the laboratory analyzing the wipe samples. These unused wipes will be processed just like the wipe samples submitted from inspections. This safeguarding step will help the inspector determine if the wipe media chosen digests adequately and/or are contaminated with elevated levels of lead. These precautions will reduce the likelihood of the inspector's having to invalidate a set of samples because of errors in analysis or due to presence of existing contamination.

Do not use wipes that contain aloe because of possible background contamination from the soil the aloe plant was grown in. Wipes that contain alcohol may be used as long as they do not dry out during the wipe process. Any wipe material that yields 80 to 120 percent recoveries can be used (measured on wipes spiked with lead dust).

Consult the analytical laboratory for additional advice on the appropriate wipe sample material. ASTM has developed a standard specification for wipe sampling materials (E 1792-96a) that is useful for the inspector and the laboratory when choosing a brand of disposable wipe appropriate for dust wipe sampling. Some laboratories will provide a sampling kit to the inspector that contains all the sampling supplies needed to collect dust wipe samples, including disposable wipes, centrifuge tubes, field sampling forms, labels, and overnight mailing labels and envelopes.

Nonsterilized, Nonpowdered Disposable Gloves

Disposable gloves are required to prevent cross-sample contamination from hands. Such gloves can be purchased from medical supply and drug stores. Some forms of talc used to powder gloves may have lead contamination.

Do not use wipes containing aloe.

Some laboratories will provide disposable wipes to the inspector.

Any wipe material that yields 80-120 percent recoveries of a wipe spiked with lead dust can be used.



Centrifuge Tubes

Use nonsterilized polyethylene centrifuge tubes (50 ml size) with sealable caps or an equivalent hard-shell container that can be rinsed quantitatively in the laboratory. These can be purchased from scientific equipment companies and medical or chemical supply companies. Ziploc™-style bags are not recommended for dust sampling containers as their use increases the risk of sample loss since it is more difficult to rinse out a bag than a hard-shell container.

Dust Sample Collection Forms

See Forms 15.2 or 15.2a in the *HUD Guidelines* (also found at the end of this section) or equivalent.

Template Options

- Hard, smooth, reusable templates made of laminated paper, metal, or plastic. Disposable templates are also permitted so long as they are not used for more than a single surface. Templates must be larger than 0.1 ft² but smaller than 2 ft². Templates for floors are typically 1 ft². Templates are usually not used for windows because of the variability in size and shape (inspectors should use masking tape instead). Reusable templates must be cleaned after each sample. Note: Inspectors should take periodic wipe samples from the templates to determine if the template is contaminated.
- Masking tape. Masking tape is used on-site to define the area to be wiped. Masking tape is required when inspectors are wiping window sills and window troughs in order to avoid contact with window jambs and channel edges. Masking tape on floors is used for outlining the exact area to be wiped.

Additional Sampling Supplies

Along with the materials for the template, the inspector may also need the following for dust sampling:

- Container labels or permanent marker
- Trash bag or other receptacle (do not use pockets or trash containers at the residence)
- Rack, bag, or box to carry tubes (optional)
- Measuring tape
- Disposable shoe coverings (optional).

Inspectors should use a template when sampling floors.

Masking tape is often used to define the area to be wiped on window sills and troughs.



Single-surface Wipe Sampling Procedure

Outline Wipe Area

Floors: Identify the area to be wiped. Do not walk on or touch the surface to be sampled (the wipe area). Apply adhesive tape to the perimeter of the wipe area to form a square or rectangle of about one square foot. No measurement is required at this time. The tape should be positioned in a straight line, and corners should be nominally perpendicular. Do not touch the wipe area when putting down any template.

Window sills and other rectangular surfaces: Identify the area to be wiped. Do not touch the wipe area. Apply two strips of adhesive tape across the ends of the sill to define a wipe area at least 0.1 square foot in size (at least 4 inches x 4 inches). It is not necessary to tape the length of the window sill.

When using tape, do not wipe outside of the outlined area but be sure to wipe the entire sampling area. It is permissible to touch the tape with the wipe but not the surface beyond the tape.

Preliminary Inspection of the Disposable Wipes

Inspect the wipes to determine if they are moist. If they have dried out, do not use them. When using a container that dispenses wipes through a "pop-up" lid, the first wipe in the dispenser at the beginning of the day should be thrown away. The first wipe may be contaminated by the lid and is likely to have dried to some extent. Rotate the container before starting to ensure liquid inside the container contacts the wipes.

Preparation of Centrifuge Tubes

Examine the centrifuge tubes and make sure that the tubes match the tubes containing the blind spiked wipe samples. Label each tube with its own specific identification number and record the identification number on the sample collection form. Partially unscrew the cap on the centrifuge tube to be sure that it can be opened. *Do not* use plastic bags to transport or temporarily hold wipe samples. The laboratory cannot measure lead left on the interior surface of the plastic bag.

Gloves

Put a clean, disposable glove on one hand; use a new glove for each sample collected. If you need to use two hands to handle the sample, use a new glove for each hand. It is not necessary for you to wipe the gloved

Area wiped must be at least 0.1 ft² and no more than 2 ft².

Do not use plastic bags to transport or temporarily hold wipe samples.

Use a new, clean glove for each sample collected.



hand before sampling. Use a new glove for each sample collected. Do not touch any surface other than the wipe after putting on the glove.

Initial Placement of Wipe

Place the wipe at one corner of the surface to be wiped with wipe fully opened and flat on the surface.

First Wipe Pass (side-to-side)

With the fingers together, grasp the wipe between the thumb and the palm. Press down firmly, but not excessively with both the palm and fingers (avoid using the heel of the hand). Do not touch the surface with the thumb. If the wipe area is a square, proceed to wipe side-to-side with as many "S"-like motions as are necessary to completely cover the entire wipe area. (See explanation below for nonsquare areas.) Exerting excessive pressure on the wipe will cause it to curl. Exerting too little pressure will result in poor collection of dust. Do not use only the fingertips to hold down the wipe, because there will not be complete contact with the surface and some dust may be missed. Attempt to remove all visible dust from the wipe area.

Wipe the area using side-to-side 'S'-like motions.

Second Wipe Pass (top-to-bottom)

Fold the wipe in half with the contaminated side facing inward. (You can straighten out the wipe by laying it on the wipe area, contaminated side up, and folding it over.) Once the wipe is folded, place it in the top corner of the wipe area and press down firmly with the palm and fingers. Repeat wiping the area with "S"-like motions; but, on the second pass move in a top-to-bottom direction. Attempt to remove all visible dust. Do not touch the contaminated side of the wipe with the hand or fingers. Do not shake the wipe in an attempt to straighten it out, since dust may be lost during shaking.

(Note: The ASTM and EPA methods add a third pass around the perimeter of the area wiped.)

Rectangular Areas (e.g., window sills)

If the surface is a rectangle (such as a window sill), two side-to-side passes must be made, the second pass with the wipe folded so that the contaminated side faces inward. For a window sill, do not attempt to wipe the irregular edges presented by the contour of the window channel. Avoid touching other portions of the window with the wipe. If paint chips or gross debris are in the window sill, attempt to include as much of them as possible on the wipe. If all of the material cannot be picked up with



Dust Sampling for Lead Contamination

one wipe, field personnel may use a second wipe at their discretion and insert it in the same container. Consult with the analytical laboratory to determine if they can perform the analysis with two wipes as a single sample. When performing single-surface sampling, do not use more than two single-surface wipes for each container. If the area is heavily dust laden, a smaller area should be wiped. It is not necessary for you to wipe the entire window trough, but do not wipe less than 0.10 ft² (at least 4" x 4").

Paint Chips: If a thorough visual examination was conducted before conducting clearance dust and soil sampling, the inspector shouldn't encounter many paint chips. However, chips *should* be included in the sample when they are encountered. When conducting pre-abatement dust and soil sampling, it is very likely the inspector will encounter paint chips on or in the surfaces being sampled. Many window troughs, exterior surfaces (e.g., porches, steps) contain paint chips or other gross debris. Remove large sticks or stones or other debris, but do not remove paint chips. Attempt to include any paint chips that adhere to the moist wipe material. Larger paint chips that do not adhere on the wipe do not need to be included in the sample.

Packaging the Wipe

After wiping, fold the wipe with the contaminated side facing inward again, and insert the wipe without it touching anything else into the centrifuge tube or other hard-shelled container. Roll or fold the wipe into the container to avoid losing sample when inserting the wipe into the tube. If gross debris is present, such as paint chips in a window trough, make every attempt to include as much of the debris as possible in the wipe.

Labelling the Centrifuge Tube (if not done before sampling)

Seal the tube and label it with the appropriate identifier. Record the laboratory submittal sample number on the field sampling form (found at the end of this section).

Area Measurement

After sampling, measure the surface area wiped to the *nearest eighth of an inch* using a tape measure or a ruler. The size of the area wiped must be at least 0.10 ft² for an adequate limit of quantitation to be obtained. No more than two square feet should be wiped with the same wipe, or else the wipe may fall apart or dry out. Record specific measurements for each area wiped on the field sampling form.

Carefully insert the wipe into the tube without it touching anything else.

Measure the area wiped to the nearest eighth of an inch.

**Form Completion**

Fill out the appropriate field sampling forms completely in ink. Collect and maintain any field notes regarding type of wipe used, lot number, collection protocol, and other appropriate data. The inspector must document in the field notes which sample(s) are field blanks or spiked samples.

Trash Disposal

After sampling, remove the masking tape and throw it away in a trash bag. Remove the glove(s); put all contaminated gloves and sampling debris used for the sampling period into a trash bag. Remove the trash bag when leaving the dwelling. Do not throw away gloves or wipes inside the dwelling unit where they could be accessible to young children, resulting in a suffocation hazard.

Repeat all of the above steps for additional samples in the same dwelling unit.

Do not discard any sampling trash within the dwelling.



Dust Sampling for Lead Contamination

Composite Wipe Sampling

Whenever composite sampling is contemplated, consult with the analytical laboratory to determine if the laboratory is capable of analyzing composite samples. No more than four individual wipes should be included in each composite sample. When conducting composite wipe sampling, you should use the procedure stated above with the following modifications:

- When outlining the wipe areas, set up all of the areas to be wiped before sampling. The size of these areas should be roughly equivalent, so that one room is not over sampled.
- After preparing the centrifuge tube, put on the glove(s) and complete the wiping procedures for all subsamples. A separate wipe must be used for each area sampled. After wiping each area, carefully insert the wipe sample into the same centrifuge tube (no more than four wipes per tube).

Inspectors do not have to change their gloves between subsample wipes for the same composite sample as long as their gloved hands do not touch an area outside of the wipe areas. If a glove is contaminated, the glove should be immediately replaced with a clean glove.

- Once all subsamples are in the tube, label the tube. Record a separate measurement for each area that is subsampled on the field collection form (included at the end of this chapter). Be certain to report the total surface area wiped to the laboratory. Finally, complete trash disposal, making sure that no masking tape is left behind.

Rules for Composite Sampling

In addition to these procedural modifications, you should observe the following rules for compositing:

- Separate composite samples are required from carpeted and hard surfaces (e.g., a single composite sample should not be collected from both carpeted and bare floors). Whenever possible, hard floors should be sampled instead of carpets. Carpets come in many types and forms. Collection efficiencies may vary considerably on carpets rendering lead loading collected on such surfaces inaccurate.
- Separate composite samples are required from each different component sampled (e.g., a composite sample should *not* be collected with both floor and window sill subsamples contained in one composite sample).
- Separate composite samples are required for each dwelling.

Contact your lab before collecting composite wipe samples.

All areas of a component wiped should be roughly equivalent.

Always collect separate composite samples from each different component sampled.



Do not insert more than four wipes into a single composite sample container.

- Floor surface areas sampled in each room should be approximately the same size (1 ft² or 929 cm²). Window trough and interior window sill sampling sizes are dependent on window characteristics but should be as similar as possible from room to room (e.g., the surface sampling area should not be skewed so that one room is over sampled).
- Do not use the same wipe to sample two different spots. Always use a new wipe for each spot sampled.
- Do not insert more than four different wipes into a single container for a composite sample. Acceptable recovery rates (80 to 120 percent of the "true" value) have been found when no more than four wipes are analyzed as a single sample.
- If composite samples are collected, composite blank and spiked (control) QA/QC samples should also be submitted for analysis.



Blank Preparation

After sampling the final dwelling unit of the day, but before decontamination, you should obtain field blank samples. Analysis of the field blank samples determines if the sample media are contaminated. Each field blank should be labeled with a unique identifier similar to the others so that the laboratory does not know which sample is the blank (i.e., the laboratory should be "blind" to the blank sample).

Collect blank wipes by removing a wipe from the container with a new glove, shaking the wipe open, refolding the wipe just as is done during the actual sampling procedure, and then inserting it into the centrifuge tube without touching any surface or other object. One blank wipe is collected for each dwelling unit sampled, or, if more than one dwelling unit is sampled per day, one blank for every 50 field samples, whichever is less. Also, collect one blank for every lot used. Record the lot number on the field sampling form.

**Never label field blanks "blank."
Always use a unique sample number.**

**Blank samples serve two purposes:
Is the media contaminated?
Is the inspector's sampling technique poor?**



Inspector Decontamination

During sampling, inspectors must not eat, drink, smoke, or otherwise cause hand to mouth contact.

After sampling, an inspector should wash his/her hands thoroughly with plenty of soap and water before getting into a vehicle. They can use a bathroom in the dwelling unit for this purpose, with the owner's or resident's permission. If there is no running water in the dwelling unit, wet wipes can be used to clean hands.



Spiked Sample Submission

Samples spiked with a known amount of lead dust (sometimes called "control samples") should be inserted into the sample stream randomly by the person conducting field sampling to determine if there is adequate quality control of the digestion process at the laboratory. Dust-spiked wipe samples should be submitted blindly to the laboratory by the individual performing field sampling at the rate of no less than one for every fifty field samples. Any laboratory can spike wipe samples using the procedure in Appendix 14.3 in the 1995 HUD *Guidelines*. The laboratory performing the analysis of the field samples can also prepare the spiked sample as long as the person performing the field sampling makes the spiked sample indistinguishable from the field samples. The person conducting the field sampling should take the spiked sample prepared in the laboratory and relabel the container with an identifier similar to the other field samples. The spiked sample wipe should not be put into another container. Spiked samples should be made using the same lot number of wipe media as that used in the field.

A dust-spiked sample is defined as a wipe or filter containing a known weight of lead-based paint dust, measured to the nearest 0.1 μg of lead dust. A dust-spiked sample is prepared in a laboratory with the amount of lead-based dust present being between 50 to 1000 μg . For wipe samples, labs should use *NIST Standard 1579a* ("Powdered Lead-based Paint") or an equivalent secondary standard. See Appendix 14.3 in the HUD *Guidelines* for further details.

A spike sample is a wet wipe spiked with a know amount of lead to test the laboratories ability to analyze dust wipe samples.

An inspector should submit one spiked sample for every 50 field samples.



Quality Assurance/Quality Control

Blind analysis of spiked samples must fall within 80 to 120 percent of the true value. If the laboratory fails to obtain readings within the QA/QC error limits, two more spiked samples should be sent immediately to the lab for analysis. If either of the two additional spiked samples fails, the sample batch should be considered invalid. A full review of laboratory procedures may be necessary. Additional samples may need to be collected from the dwelling units from locations near the locations previously sampled.

If more than 50 $\mu\text{g/wipe}$ is detected in a blank sample, the samples should be collected again since the media are contaminated. Blank correction of wipe samples is *not* recommended.



Advantages and Disadvantages of Composite Wipe Sampling

Many types of environmental samples are composited in order to make them more representative of larger areas. For example, soil samples are routinely combined from separate areas into one large sample, which is then mixed and combined into one sample. Air samples are often composited over time to express time-weighted averages. Wipe samples can also be composited.

Advantages of composite sampling are

- a lower cost per surface sampled;
- increased surface area that can be wiped for the same cost.

Disadvantages are that

- information on a specific sampling location is lost;
- laboratories will have to adopt special handling and digestion procedures. (In order to obtain defensible analysis results, any adopted special handling and digestion [or extraction] procedures for composite samples should be capable of producing data with the same degrees of accuracy and precision as for single wipe samples, and preferably recognized by the accrediting bodies.

The composite samples should be collected from the following components:

- bare floors (or carpeted floors for wall-to-wall carpeting);
- window sills;
- window troughs;
- exterior surfaces.

Be sure to explain to the client the advantages and disadvantages of composite wipe sampling.



When to Use Single-surface and Composite Wipe Samples

Single-surface wipe samples should be used

- when information is needed to determine leaded dust levels in a specific location. (For example, pet sleeping areas, porch areas, laundry areas where contaminated clothing is washed, or lead hobby areas);
- in other areas where leaded dust levels are expected to be high to determine if targeted cleaning efforts are needed.

Composite wipe samples should be used

- when controlling costs is essential;
- when there is no reason to suspect that dust levels from the same types of surfaces in different rooms will vary greatly;
- when the costs of multiple-room cleanup will not greatly exceed the cost of single room cleanup.

The determination of whether to use single-surface or composite samples is a matter of professional judgment to be exercised on a case-by-case basis.

According to the recommendations in the HUD *Guidelines*, if single-surface clearance sampling is conducted and a surface fails, only those surfaces in that room must be recleaned (unless the sampling is done randomly in multifamily housing, then all the surfaces represented by that sample must be recleaned). If composite sampling is conducted and a surface fails, all the rooms with that component must be recleaned.

If using composite sampling and a surface fails, all the rooms with that component must be recleaned.



Avoiding Cross-sample Contamination

Since the hands, although gloved, are used to touch the wipe sampling media, the potential for cross-contamination is high. Cross-contamination means that other surfaces coming into contact with the wipe could deposit lead on the wipe, making it impossible to determine the source of the lead. Inspectors can follow several easy rules to eliminate this problem:

- Always change gloves for each sample collected. For composite samples, gloves need to be changed only for each composite, not for each subsample.
- After donning the glove, do not touch anything other than the wipe and the surface to be sampled.
- If the wipe is dropped or accidentally used to wipe an area outside the marked area, discard the wipe and sample another nearby area.
- Discard the first wipe from the dispenser at the start of each dwelling unit sampled.
- Fold the wipe completely before inserting the wipe into the tube to avoid sample loss in the packaging process.

Cross-contamination means that the other surfaces come into contact with the wipe.



Sampling Data Forms

Two sample forms—*Lead Hazard Control Clearance Dust Sampling Form (Single-Surface Sampling)* and *Lead Hazard Control Clearance Dust Sampling Form (Composite Sampling)*, included at the end of this section, are taken from the *HUD Guidelines* and can be used for recording dust sampling data.



Dust Sampling for Lead Contamination

Number and Location of Wipe Samples

The EPA work practice standards establish a minimum number of dust-wipe samples to be collected following lead-based paint abatement activities in single- and multifamily housing. The HUD *Guidelines* provides additional recommendations for the number and location of wipe samples to be taken by the inspector for a dwelling to achieve postabatement clearance. This discussion incorporates both agencies requirements/recommendations.

The decision to conduct dust-wipe sampling and the number of samples varies, depending on

- whether the hazard control work was conducted on the interior or exterior of the dwelling,
- the number of rooms treated (i.e., whether the entire interior was involved or only part of the dwelling); and
- the type of sampling conducted (i.e., single surface or composite).

Table 9-1 indicates the recommended minimum number and suggested location of clearance dust samples based on the HUD *Guidelines*. The table is divided into four categories of clearance:

- interior treatments with no containment within the dwelling;
- interior treatments with plastic sheeting as airlocks on doors and between treated and untreated areas;
- exterior treatments; and
- routine maintenance work.

The EPA work practice standards have no requirements for dust-wipe sampling following abatement exclusively on the exterior of a dwelling. The inspector is required to conduct a visual inspection of all horizontal surfaces in the outdoor living areas closest to the abated surface(s) to determine that they are free of visible dust and debris. However, the contract specifications for the project may require both pre- and postabatement dust sampling of the outdoor living areas to ensure the contractor does not leave excessive levels of lead dust on the outside of a dwelling.

The inspector should take clearance dust samples either from specific locations near the area where the lead hazard-control work was done, from nearby high-traffic areas, or from other areas. The inspector should not disclose the location of sampling to the abatement contractor.

The number of postabatement clearance samples to collect depends upon the number of rooms treated, the type of sampling conducted, and whether work was done on the interior or exterior.

EPA does not require dust wipe sampling following abatement exclusively on the exterior of a dwelling.

**Sampling of Multifamily Housing (20 or more units)**

When conducting clearance sampling in multifamily housing, the EPA regulations require that a sufficient number of residential dwellings are selected for dust sampling to provide a 95 percent level of confidence that no more than five percent or 50 of the residential dwellings (whichever is smaller) in the randomly sampled population exceed the appropriate clearance levels.

The HUD *Guidelines* recommends that the inspector sample a number of randomly selected dwelling units where similar units have undergone comparable types of lead hazard control activity. The random sampling can be performed for a portion of the housing development or for all of it. In either case the randomly selected units represent a specified group of housing units. The number of units sampled is determined in the same manner as for a lead-based paint inspection—using Table 7.3 of the HUD *Guidelines* (Table 7.3 in Chapter 7 of this curriculum). This procedure, if followed, would achieve the EPA required level of confidence.

If random clearance sampling is conducted, the owner and hazard control contractor should be aware that if the sampling shows that levels of leaded dust exceed the clearance limits, it will be necessary to reclean not only the affected component in the selected dwelling unit, but also the affected component in *all* the other units that the randomly selected unit was meant to represent. Alternatively, all the units represented by the randomly selected unit could be sampled individually to determine which ones need recleaning. The costs of repeated sampling should be compared with the costs of repeated cleaning.

In multifamily housing, inspectors should use table 7.3 to determine how many units to sample.

Dust Sampling for Lead Contamination

Table 9-1 Recommended Minimum Number and Location of Clearance Dust Samples

Clearance Category	Category Description	Number and Location of Single-Surface Wipe Samples in Each Area ¹	Number and Location of Composite Wipe Samples
1	Interior treatments No containment within dwelling	Two dust samples from at least four rooms in dwelling (whether treated or untreated); <ul style="list-style-type: none"> • One interior window sill or window trough (if present). • One floor. AND <ul style="list-style-type: none"> • For common areas, one for every 2,000 ft² of a common area room floor (if present). 	Three composite samples for every batch of four rooms (whether treated or untreated): <ul style="list-style-type: none"> • One floor composite. • One interior window sill composite. • One window trough composite. AND <ul style="list-style-type: none"> • For common areas, one floor subsample for every 2,000 ft² (if present); up to 8,000 ft² can be sampled for each composite.
2	Interior treatments With containment (plastic sheeting as airlock on doors between treated and untreated areas)	Same as Category 1 but only in every treated room (up to four rooms) AND One floor sample outside the containment area but within ten feet of the airlock to determine the effectiveness of the containment system. This extra single-surface sample is recommended in 20 percent of the treated dwellings in multifamily housing and <i>all</i> single-family homes. <ul style="list-style-type: none"> • For common areas, one floor sample for every 2,000 ft² and one floor sample outside containment. 	Same as Category 1 but only in every treated room AND One floor sample outside the containment area but within ten feet of the airlock to determine the effectiveness of the containment system. This extra single-surface sample is recommended in 20 percent of the treated dwellings in multifamily housing and <i>all</i> single-family homes. <ul style="list-style-type: none"> • For common areas, one floor subsample for every 2,000 ft² (up to 8,000 ft² for each composite) and one floor sample outside containment.
3	Exterior treatments	Two dust samples as follows: <ul style="list-style-type: none"> • At least one dust sample on a horizontal surface in part of the outdoor living area (e.g., a porch floor or entryway). • One window trough sample (if present) on each floor where exterior work was performed. An additional trough sample should be collected from a few lower floors to determine if troughs below the area were contaminated by the work above. 	Two dust samples as follows: <ul style="list-style-type: none"> • One composite on a horizontal surface in part of the outdoor living area (e.g., a porch floor or entryway). • One window trough composite for every four floors where exterior work was performed, including lower floors where exterior work was not done, if present.
4	Routine maintenance work	At least one floor dust sample for every 20 high-hazard jobs near the work area (see Chapter 17 of the HUD <i>Guidelines</i> for definitions of "high hazard").	Same as single-surface sampling.

¹ A room includes a hallway or a stairway. If no window is present, collect just one floor sample. When a closet is treated, the room to which it is attached should be tested. A closet is not considered to be a separate room. If all rooms received similar treatments and cleaning, only four rooms need to be sampled for clearance purposes. More rooms may need to be sampled in larger dwellings. The room to be sampled should be selected based on where most of the dust-generating work was done or in the judgment of the clearance examiner.



Sampling in Single-Family Housing and Multifamily Housing (Fewer than 20 units)

The HUD *Guidelines* recommends that clearance dust sampling be conducted in every single-family dwelling unit and in all multifamily housing with fewer than 20 units. Random sampling is inappropriate because treatment and housing conditions vary so greatly in these housing units.

Sampling of Common Areas

HUD also provides recommendations on sampling in common areas. The number and location of the samples are dictated by the size (in increments of 2,000 ft²) of the common area. The selection of which common areas to sample should be dictated by their proximity to the hazard control activity and if specific common areas were used by the lead hazard control work crew during their activities.

For all interior treatments, floors in common areas are the only surface sampled; for exterior treatments, the inspector includes a window trough from each story (in multistory buildings) where exterior work was performed. As a reminder, EPA rules do not require dust-wipe sampling after abatement conducted exclusively on the exterior of a dwelling. A visual inspection of horizontal surfaces within outdoor living areas is all that is required.

Common areas should also be sampled after abatement.



Dust Sampling for Lead Contamination

Sampling after Routine Maintenance Work

In Chapter 17 of the *Guidelines*, HUD recommends that a visual examination be conducted by a trained work crew supervisor after every routine building maintenance job which affects a lead painted surface. In addition, HUD recommends at least one floor dust sample be taken near the work area for every 20 high-hazard jobs. HUD defines a high hazard job as:

- Repainting (including surface preparation)
- Plaster or wall repair
- Window repair
- Water or moisture damage repair
- Building component replacement
- Welding on painted surfaces
- Floor refinishing
- Carpet replacement
- Baluster repair (metal)
- Demolition.

Although it may not be a requirement to do so, it is possible that a building owner or manager may contract with a certified or licensed lead-based paint inspector to conduct dust-wipe sampling after some routine maintenance jobs to verify that the work crew is cleaning up properly. The new HUD rules will require clearance dust sampling after many renovation and remodelling activities that disturb painted surfaces.

HUD rules require clearance dust sampling after many renovation and remodelling jobs.

Interpretation of Test Results

Typically, results are reported from the laboratory as total weight of lead present on the wipe. The inspector must then convert the reported result to units of micrograms per square foot ($\mu\text{g}/\text{ft}^2$) for direct comparison to the clearance standards.

Example:

The laboratory reports 80 micrograms of lead on a wipe taken from a window sill. The area wiped by the inspector measured 3 inches (0.25 ft) by 2 feet 6 inches (2.5 ft).

Step 1: Determine the total area sampled in square feet

$$0.25 \text{ ft} \times 2.5 \text{ ft} = 0.625 \text{ ft}^2$$

or, another way to determine total square feet is to convert from square inches into square feet using the formula 1 square foot = 144 square inches.



$$3 \text{ inches} \times 30 \text{ inches} = 90 \text{ square inches}$$

$$90 \text{ square inches} \times 1 \text{ square foot}/144 \text{ square inches} = 0.625 \text{ ft}^2$$

Step 2: Using the value for the amount of lead reported by the lab and the total square feet sampled, convert the results into $\mu\text{g}/\text{ft}^2$

The total amount of lead present is 80 μg .

Now the inspector must equate the 80 micrograms in 0.625 square feet into micrograms/one square foot ($\mu\text{g}/\text{ft}^2$):

Thus, the concentration of lead in the dust is

$$80 \mu\text{g} \div 0.625 \text{ ft}^2 = 128 \mu\text{g}/\text{ft}^2$$

Does this surface pass the EPA clearance level for window sills?

Does this surface pass the HUD clearance level for window sills (effective 15 September 2000)?

The answer to both questions is "yes."

When the inspector interprets the results of clearance sampling, the following procedures are recommended. When using single-surface sampling:

- if any surface fails, all surfaces of that type in the rooms (whether sampled or unsampled) should be recleaned. (Note: If a specific surface (e.g., the window trough in bedroom # 3) was already tested and passed, it does not need to be recleaned and resampled.)

When the inspector uses composite sampling, if any surface in any unit fails, that surface should be recleaned in all units, even those units which were not tested. A composite sample provides the inspector with the

Final dust wipe sample results must be reported in $\mu\text{g}/\text{ft}^2$.



Dust Sampling for Lead Contamination

average lead loading in all rooms sampled to determine if *all* the rooms require additional cleaning.

The recleaning should be focused on those surfaces for which the first round of cleaning was inadequate. For example, if floor leaded dust levels are above the standard, but interior window sills and troughs are below the standard, then only the floors need to be recleaned. Similarly, if single-surface samples fail in one room, then only that surface in that room and any rooms not sampled need to be recleaned. If composite samples fail then *all* the surfaces the composite represents need to be recleaned (or each unit sampled individually to determine which one(s) require recleaning).

Using the data provided in Table 9-2, determine which of the surfaces pass the EPA interim clearance standards. Which of the surfaces pass using the HUD clearance standards? Assume a six-room dwelling with no containment between the rooms. All rooms were abated.

Table 9-2 Example of Clearance Dust Sampling Data

Room	Floors ($\mu\text{g}/\text{ft}^2$)	Interior sills ($\mu\text{g}/\text{ft}^2$)	Troughs ($\mu\text{g}/\text{ft}^2$)
Kitchen	312	40	60
Bedroom #1	65	65	90
Bedroom #2	40	70	75
Living room	25	60	80

**Answers:**

If this property was not classified as federally-owned or assisted, the EPA interim clearance levels would apply. In that case, only the floor sample from the kitchen is above the interim standard of $100 \mu\text{g}/\text{ft}^2$ limit, so the floor in the kitchen and the other two rooms which were not sampled should be recleaned. This is because the samples actually taken represent only a small part of the total area cleaned. All other surfaces pass the clearance dust sample levels.

However, if this property was classified as federally-assisted housing, then the HUD clearance dust standards would apply. In that case, the floors in the kitchen and bedroom number one would fail; while the interior sills and window troughs all pass. Therefore, the floors of the kitchen and bedroom number one and the two remaining unsampled rooms would have to be recleaned and resampled.

Remember—when EPA issues final lead hazard standards, HUD will incorporate those levels into their rules.



Dust Sampling for Lead Contamination

**Lead Hazard Control Clearance Dust Sampling Form
(Single-Surface Sampling)**

Date _____

Name of clearance examiner _____

License or certification number _____

Name of property owner _____

Property address _____ Apt. no. _____

Clearance categories:

1. Interior treatments without containment
2. Interior treatments with containment
3. Exterior work on painted surfaces
4. Routine maintenance
5. Soil work

Sample number	Room number or identifier	Surface type (floor, interior window sill, window trough)	Clearance category number	Dimensions of sample area (inches)	Area (ft ²) (can be completed by lab)	Results of lab analysis (µg/ft ²) (can be completed by lab)	Pass or Fail

Total number of samples on this page _____

Page _____ of _____

Date of sample collection / / Date shipped to lab / /

Relinquished by _____ Received by _____
(Signature) (Signature)

Date / / Date / /

Relinquished by _____ Received by _____
(Signature) (Signature)



Inspecting for Lead-based Paint





Dust Sampling for Lead Contamination

**Lead Hazard Control Clearance Dust Sampling Form
(Composite Sampling)**

Date _____

Name of clearance examiner _____

License or certification number _____

Name of property owner _____

Property address _____ Apt. no. _____

Clearance categories:

1. Interior treatments without containment
2. Interior treatments with containment
3. Exterior work on painted surfaces
4. Routine maintenance
5. Soil work

Sample number	Name of room or identifiers included in sample	Dimensions of surface sampled in each room (inches x inches)	Total surface area sampled (ft ²)	Type of surface sampled (smooth floors, carpeted floors, interior window sills, window troughs)	Clearance category number	Lab result (µg/R ²)	Pass or Fail

Total number of samples on this page _____

Page _____ of _____

Date of sample collection ___/___/___ Date shipped to lab ___/___/___

Relinquished by _____ (Signature) Received by _____ (Signature)

Date ___/___/___ Date ___/___/___

Relinquished by _____ (Signature) Received by _____ (Signature)



Inspecting for Lead-based Paint

Vertical line of text, likely bleed-through from the reverse side of the page.



Suppliers of Dust Wipe Media

AIHA is aware that the following wipe media are alleged to meet the performance requirements of ASTM E1792. This list is for information only and is not intended to be all-inclusive. AIHA does not endorse nor recommend any particular wipe. Each organization needs to verify with the manufacturer that they do meet ASTM E1792 requirements on a continuing basis.

Pace Wipes

Available from LG Best & Associates, Inc., 207 Rutherglen Drive, Cary, NC 27511 (919) 467-0466

Pallintest Dust Wipe

Available from Pallintest USA, 21 Kenton Lands Road, Erlanger, KY 41018, (800)835-9629.

Lead Wipe (Aramco)

Available from Lynx Products, Thorofare, NJ (800)767-8933. This wipe has been found to meet the performance aspects of the ASTM spec., but does not meet the labeling requirements in that it does not list non-proprietary ingredients.

Wash'n Dri Moist Disposable Towellettes

Available from Softsoap Enterprises, Chaska, MN 55318; (800)255-7552. This wipe contains a detergent system which causes interference with ASV analysis. Unlike the other two wipes listed, it is not marketed specifically for lead dust sampling and analysis.

Ghost Wipes

Available from Environmental Express, 490 Wando Park Blvd., Mt. Pleasant, SC 29464; 1-800-343-5319. This wipe readily dissolves in hot water or acid solutions.

[Back to Laboratory Accreditation](#) [Back to AIHA Home Page](#)

Last Updated on January 19, 2001 by jimvera@aiha.org Copyright 2001, American Industrial Hygiene Association <http://www.aiha.org/wipamed.html>



CHAPTER 10

SOIL SAMPLING FOR LEAD CONTAMINATION

Objectives	10-3
Learning Tasks	10-4
Sources of Lead in Soil	10-5
Clearance Inspections	10-6
Soil Sampling Collection Techniques	10-8
Number and Location of Soil Samples	10-10
Interpretation of Soil Sampling Results	10-14
Field Sampling Form for Soil	10-16



Inspecting for Lead-based Paint

Soil Sampling for Lead Contamination

Objectives

The objectives of this chapter are to

- provide inspectors with basic information on how soil exposure contributes to the blood-lead levels found in children;
- provide inspectors with detailed information on conducting testing for lead contamination in soil;
- identify the EPA interim guidance on soil lead levels where control measures should be implemented;
- identify the major reason for collecting composite soil samples as opposed to individual samples;
- discuss the inspector's role in pre- and postabatement soil sampling.





Inspecting for Lead-based Paint

Learning Tasks

After completing this chapter, inspectors should be able to

- conduct and evaluate results of soil testing for lead, including potential remedial actions;
- understand the contribution of lead-contaminated soil to the lead levels present in interior and exterior dust;
- explain how soil exposure contributes to the blood lead levels found in children;
- identify at least five ways that soil surrounding a dwelling can become contaminated with lead.

As an inspector, this section is important to you because

- different sampling and testing procedures are needed when evaluating other sources of lead-contamination (other than lead-based paint);
- you may be asked to collect postabatement clearance soil samples.

Soil Sampling for Lead Contamination

Sources of Lead in Soil

Several studies have shown that soil contaminated with lead contributes significantly to the blood lead levels found in children. Children's exposure occurs through direct ingestion of soil, "track-in" of soil into the interior of the dwelling, or through a combination of the two. The soil surrounding a dwelling can be contaminated with lead from several different sources. One possibility is the weathering and "chalking" of lead-based paint on the building exterior. Many older single-family homes have exterior lead-based paint, especially in colder climates such as the Northeast and Midwest in the United States, because lead-based paint was the most durable for these applications. Soil can also be contaminated from airborne emissions from leaded gasoline. Although leaded gasoline has been generally phased out under an EPA ban, many millions of tons of lead entered the environment from this source up until the late 1980s. Therefore, for dwellings close to highways or major surface streets, considerable lead contamination of the soil is possible. A third source of contamination is from point sources of airborne lead such as lead smelters and battery manufacturing plants. These sources are less common but can be important in some areas of the country. Each of these sources has added to the naturally occurring lead in soil, which generally ranges from 5 to 50 parts per million.

Lead in soil is a direct source of lead exposure to children playing in the yard, who may get their hands dirty and then put their fingers or objects into their mouths. It is also potentially a source of lead in interior house dust since soil can easily be tracked into the dwelling by the residents and their pets. In addition, vegetables grown in lead-contaminated soil may take up lead and be ingested by the residents of the dwelling. Thus, some testing of the soil around a dwelling is highly desirable as part of an overall evaluation of lead from different sources.

Title X defines contaminated "bare soil" to be a lead-based paint hazard if the lead concentration is above certain levels. Therefore, the inspector does not necessarily have to sample soil that already has a good grass or other vegetative cover unless there is some reason to believe that soil lead levels may be unusually high (above 5,000 $\mu\text{g/g}$) or unless ground covering on those sites may be disturbed by activities such as gardening or excavation.

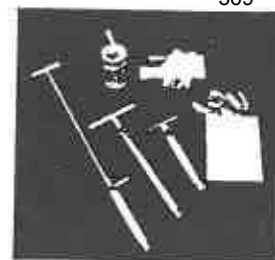

The soil surrounding a dwelling can be contaminated with lead from several sources.



Clearance Inspections

Final (postabatement) clearance inspections include the following steps:

- a visual examination for dust, debris, and paint chips on the interior;
- dust-wipe sampling;

For abatement involving the exterior of a dwelling:

- a visual inspection for dust, debris, and debris including
 - all horizontal surfaces in the outdoor living space; and
 - at the dripline or next to the foundation below any exterior surface abated.

More information on the visual examination is found in Chapter 8 and on dust sampling in Chapter 9.

The EPA work practice standards (40 CFR Part 745) do not require soil sampling after a lead abatement project. However, the HUD *Guidelines* suggests that whenever exterior painted surfaces are disturbed, the clearance inspector may choose to collect postabatement composite soil samples. This requirement should also be addressed in the contract specifications for the abatement project.

Pre- and Postabatement Soil Sampling

EPA regulations and the HUD *Guidelines* require that a certified or licensed inspector or risk assessor conduct a visual examination of soil after a hazard control strategy has been completed. However, EPA's lead inspector training requirements include both a lecture and hands-on activities on soil sampling methodologies. Clearance soil samples are collected to determine if the implemented hazard control strategy(ies) have contaminated the soil with lead. The inspector will conduct a visual examination of the property for visible contamination (i.e., paint chips) and then may also collect samples at or adjacent to the area of remediation. Other likely areas to sample include:

- areas on the property where waste containers were stored;
- nearby play areas

If clearance soil sampling is to be conducted after the hazard controls have been implemented, the specifications for the project may also require pre-abatement soil sampling. These samples are collected to determine if the soil is already contaminated with lead and also serve not only as a quality control check for the owner, but to protect the abatement contractor should the soil have existing high levels of lead. Generally, these pre-abatement soil samples are not analyzed unless the lead levels in postabatement soil samples are elevated. Then the pre-

The EPA rules do not require postabatement soil sampling.

Soil Sampling for Lead Contamination

abatement samples can be analyzed to determine if the contractor is responsible for contaminating the soil during the remediation process. In some cases, an inspector/risk assessor is hired by the abatement contractor to act as an independent third party to collect the pre-abatement soil samples as an "insurance policy" for the contractor.

The issue of comparing pre- and postabatement soil samples is a difficult one. How much of an increase in soil lead levels is acceptable? Who makes that determination? What does a contractor or owner do about an increase in soil lead levels? All of these questions *must* be addressed *before* the abatement project begins. The contract documents must clearly spell out the steps that will be taken should postabatement soil lead levels exceed the pre-abatement levels. Again, neither the EPA nor HUD regulations require pre- or postabatement soil sampling. Only a visual examination for paint chips or debris is required by the clearance inspector.

The information in the next section is provided should the inspector be asked to conduct soil sampling.



If postabatement soil samples will be collected, preabatement soil samples should also be collected.



When sampling bare soil, sample the top half-inch.

Soil Sampling Collection Techniques

The inspector should design a soil sampling strategy to

- identify the existing level of lead in the soil outside of the dwelling;
- determine if hazard control activities have contaminated the soil.

The inspector generally collects soil samples using either coring or spooning methods. A typical soil-coring probe is at least 0.5 inch in diameter, can be pushed into the ground approximately two inches, and has a capability to plunge or remove the resulting soil core such that only the top 0.5 inch of soil remains. Many types of coring devices are available, ranging from simple plastic syringes or steel pipes to professional stainless-steel coring probes. Soil-coring devices may not be useful in sandy, dry, or friable soil. In these cases, an inspector may use a plastic or stainless steel scoop or spoon or the lip of the sample container itself.

The specific equipment suggested for soil sampling is:

- a coring probe or scooping device;
- sample collection container (either a resealable plastic bag or a plastic centrifuge tube);
- disposable, nonpowdered gloves;
- steel or plastic ruler or measuring tape;
- commercial, nonaloe, disposable wipes;
- self-adhesive labels;
- pencil and marking pen;
- field sampling log.

During the sampling using a soil-recovery probe the inspector should:

- Label a new resealable plastic bag;
- Put on a pair of clean, powderless, disposable gloves;
- Push the soil-recovery probe into the soil to a depth of approximately two inches, then twist and snap the coring tool to one side, and remove the tool from the soil, being careful not to allow the soil to come out of the probe;
- Depending on the type of device, either plunge out all but the top 0.5 inch of soil or use gloved fingers to pick the top 0.5 inch out of the cutaway of the probe;
- Using the same method, collect the remaining core samples of the composite and place the three to ten cores constituting the composite sample into the same plastic container;

Collect three to ten soil cores for one composite soil sample.

Soil Sampling for Lead Contamination

- Label the plastic container with sample ID and with time, date, and location of sample. Record the same information on the field sampling log.
- Before collecting the next composite sample, thoroughly clean the coring device or other tools with a disposable wipe or water, and discard the gloves. Put on a new pair of gloves prior to collecting the next composite sample in order to avoid cross-contamination.

When the soil is hard, dry, or frozen, the inspector may have to use a hammer attachment to drive the probe into the soil to the required depth. In some circumstances, the inspector may not be able to push the probe into the soil the full two inches. In such cases, the inspector should push the probe into the soil a minimum of 0.5 inch and should record any problems encountered in the field sampling log. (See sample form on next page.)

Normally, for each sampling period or batch of samples, the inspector should collect a "field blank" by following all steps in the sampling procedure. However, because soil samples are not collected on sampling media such as a wet wipe, an inspector has no practical way of collecting a blank, and the laboratory may encounter some difficulty in processing a field blank with the other soil samples. Therefore, no field blanks are recommended for soil sampling. However, the inspector should include blind reference materials (spiked with known concentrations of lead) periodically as a quality insurance check of the laboratory.



No field blanks are recommended for soil sampling.

Spiked soil samples should be submitted periodically as a quality check of the lab.



Number and Location of Soil Samples

Because dwelling exteriors vary so widely, the inspector must perform soil sampling on a case by case basis; thus, only general guidelines on where to collect samples are provided. An inspector determines actual sampling locations based on the hazard control strategies selected by the owner and on the inspector's professional judgement. Furthermore, to keep costs affordable, the inspector must design the sampling strategy to limit the number of soil samples analyzed. However, when an inspector collects a limited number of samples from a yard, he/she should be careful to collect the samples in such a way that they are representative of the conditions found at the site. A major source of uncertainty in the results could occur if the inspector collected samples from a very small area relative to the total area of interest. For example, the inspector could theoretically take a single soil sample from an area where new soil had recently been laid or from an area where the lead concentration is unusually high. Since it is unlikely that the inspector will know this information, the inspector should sample a larger area.

The inspector selects sampling locations based on the hazard control strategy used and their professional judgement.

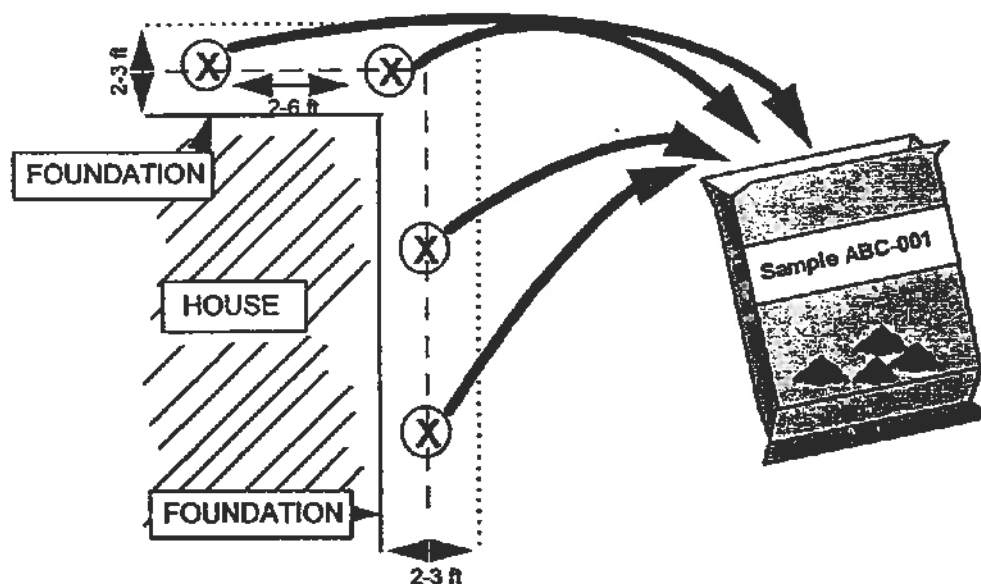

For samples collected along the foundation dripline (e.g., when exterior work was conducted on all faces of the dwelling), subsamples should be collected at least two to six feet apart. Each subsample is then placed in a single container to make up a composite sample.

Soil Sampling for Lead Contamination

The easiest and most cost-effective way for the inspector to sample from larger areas is to collect field composite samples, which consist of individual subsamples collected from three or more locations and combined into one sample for analysis. Composite sampling offers a more cost-effective approach and provides more accurate information than collecting a few single-location samples.

The inspector should collect at least one composite sample around the perimeter of the dwelling or building (i.e., garage) when conducting pre-abatement soil sampling. If only selected faces of the building are to be treated, the samples should come from those faces. A second composite soil sample should be collected from any nearby play areas and areas on the property where lead waste containers will be stored. When conducting either pre-abatement or clearance soil sampling, bare soil should be sampled preferentially. If there is no bare soil, the soil covering should be sampled to determine if it has been contaminated by the lead hazard control work. Once the inspector identifies sampling areas, then he/she can determine subsampling locations within these areas. The inspector should collect no more than ten subsamples for each composite sample.

Several strategies are suggested for various scenarios. The inspector can select subsampling locations in bare soil play areas by first sketching the area and then drawing a circle just encompassing the accessible bare area. The inspector then draws a second circle inside the first with one-



Bare soil should be divided by an x-shaped grid. Subsamples should then be collected at equidistant points along each axis.

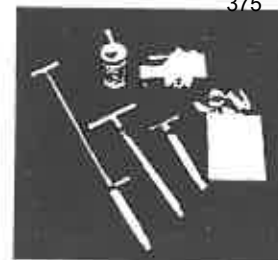

Soil samples should be collected from the perimeter of the building on which lead work was conducted.



Inspecting for Lead-based Paint

half the radius and then selects three equally-spaced sampling locations at random on the inner circle. The inspector then takes soil samples at each location.

To sample the building foundation or dripline, the inspector can take three to ten individual subsamples from the perimeter of the dwelling or building. Where possible, the inspector should locate each subsample at random in a bare soil area at the dripline on a different side of the house. These individual foundation/dripline subsamples are then composited into one sample for analysis. If hazard control work is only being done on one or two sides of a dwelling or building, then the inspector should collect soil samples from the dripline area of those sides.

The inspector may also wish to choose the following sampling strategy. Each composite sample should consist of bare area soil subsamples collected from three to ten distinct locations roughly equidistant from each other along an axis.

At other sampling locations, samples should be collected at roughly equidistant points along each axis of an "x" shaped grid. Samples should be collected from areas of bare soil.

Note that if paint chips are in the core sample taken, they should be included as part of the sample. Paint chips should not be excluded from the soil sample if they are a part of the soil matrix. However, there should be no attempt to oversample paint chips.

To assist in interpretation of the results, the inspector may also wish to make a detailed drawing showing the boundary of the lot; the position of the main building and any other structures such as garages and storage sheds; the position of the sidewalks, driveways, and other paved areas; the position of the play areas (if clear); the position of areas with exposed soil; areas used to store waste containers during the hazard control activities; the drip lines of the buildings; and areas of worker traffic (if known).

In addition to this diagram, it may also be beneficial to describe the location of the property, including the following information:

- type of building construction;
- condition of main building;
- condition of the property and nature of adjacent property; and
- apparent use of the property (e.g., use as a play area).

If hazard control work is only done on one or two sides of a dwelling, sample only those sides.

Soil Sampling for Lead Contamination

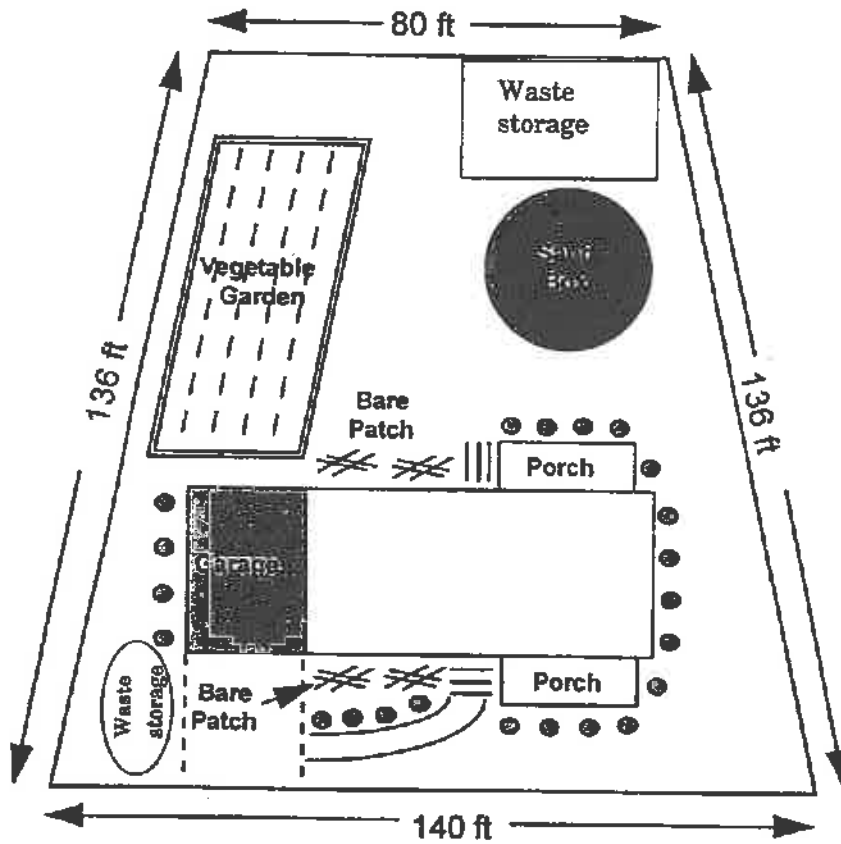
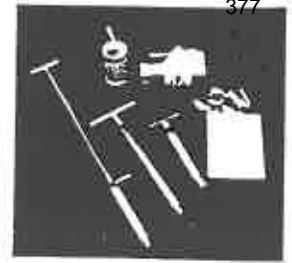

Note: Not drawn to scale.

Example of site description showing lot boundary, building location, garage location, play area (sand box), areas of bare soil, and areas of waste storage.

Include the boundary lines and positions of dwelling and any other structures in a diagram.



Interpretation of Soil Sampling Results

Laboratory analysis of soil core samples for lead are generally carried out using atomic spectrometry methods, where the samples are converted from a solid to a liquid before measuring the lead concentration.

Typically, sample preparation involves drying and sieving (to homogenize) the soil followed by a digestion process that dissolves the lead in the sample. The results are reported in parts lead per million parts of soil by weight (ppm), mg/kg, or $\mu\text{g/g}$. Some laboratories may also report concentration in weight percent, which can be converted to $\mu\text{g/g}$ by moving the decimal point to the right four places:

$$0.5\% = 5,000 \mu\text{g/g}$$

Because a single composite sample may contain up to ten single subsamples, the composite sample lead concentration represents an average soil lead concentration over the area where the cores were taken. For example, the composite taken close to the foundation, and consisting of cores at random locations in this area, represents an estimate of the average soil lead concentration close to the foundation of the dwelling.

Currently, EPA is developing health-based standards for lead in soil under the Toxic Substances Control Act (TSCA), Title X, Section 403. However, until a Federal standard is developed, interim guidance levels have been put forth. EPA suggests the following levels of concern for residential bare soil lead concentrations:

- 400 $\mu\text{g/g}$ high contact play areas
- 2,000 $\mu\text{g/g}$ other residential yard areas
- 5,000 $\mu\text{g/g}$ levels requiring permanent abatement

The response recommended is based on the area of concern and the likelihood of contact by children. The recommended response activities at these levels are summarized in Table 10-1.

In June of 1998, EPA published proposed standards defining lead-based paint, dust, and soil hazards (*Federal Register*, Vol 63, No. 106, 3 June 1998). This proposed rule revises the levels of concern for soil listed previously. *However, in the preamble to the proposed rule, EPA clearly states that the levels published in July 1994 and republished in the Federal Register in September 1995 will continue to serve as EPA's official policy until final standards are promulgated under TSCA section 403.*

Until EPA issues final health-based lead-contaminated soil standards, use the levels taught in this course.

Soil Sampling for Lead Contamination

Table 10-1—EPA Recommendations for Response Activities for Residential Lead-contaminated Bare Soil		
Area of Concern	Bare Soil Lead Concentration (ppm)	Recommended Response Activities
<p>Areas expected to be used by children, including</p> <ul style="list-style-type: none"> • residential backyards • day care and school yards • playgrounds • public parks • other areas where children gather 	400-5,000	<p>Interim controls to change use patterns and establish barriers between children and contaminated soil, including</p> <ul style="list-style-type: none"> • planting ground cover or shrubbery to reduce exposure to bare soil • moving play equipment away from contaminated bare soil • restricting access through posting, fencing, or other actions • control further contamination of area <p>Monitor condition of interim controls</p> <p>Public notice of contaminated common areas by local agency</p>
	> 5,000	<p>Abatement of soil, including</p> <ul style="list-style-type: none"> • removal and replacement of contaminated soil • permanent barriers <p>Public notice of contaminated common areas by local agency</p>
<p>Areas where contact by children is less likely or infrequent</p>	2,000-5,000	<p>Interim controls to change use patterns and establish barriers between children and contaminated soil, including</p> <ul style="list-style-type: none"> • planting ground cover or shrubbery to reduce exposure to bare soil • moving play equipment away from contaminated bare soil • restricting access through posting, fencing, or other actions • control further contamination of area <p>Monitor condition of interim controls</p> <p>Public notice of contaminated common areas by local agency</p>
	> 5,000	<p>Abatement of soil, including</p> <ul style="list-style-type: none"> • removal and replacement of contaminated soil • permanent barriers <p>Public notice of contaminated common areas by local agency</p>



CHAPTER 11

SAMPLE ANALYSIS AND LABORATORY ACCREDITATION

Objectives	11-3
Learning Tasks	11-4
Analytical Techniques	11-5
Atomic Absorption Spectrometry	11-5
Atomic Emission Spectrometry	11-6
Anodic Stripping Voltametry	11-6
Analysis of Paint Chip Samples.....	11-8
Analysis of Soil Samples	11-9
Analysis of Dust Wipe Samples	11-10
Wet Chemical Field Test Kits	11-11
Laboratory Accreditation	11-13
ASTM Standards	11-14

Inspecting for Lead-based Paint



Sample Analysis and Laboratory Accreditation



Objectives

The objectives of this chapter are to

- provide inspectors with information about the commonly used analytical techniques for identifying lead in various media;
- provide inspectors with basic information about field testing methods for detecting lead in paint and other media;
- compare field methods with traditional analytical test methods;
- outline the elements of the laboratory accreditation process.



Learning Tasks

After completing this chapter inspectors should be able to

- identify the analytical techniques commonly used for identifying lead in various media;
- understand the basic theory behind each technique and the main differences in each method;
- identify the two types of wet chemical field test kits and understand the differences between them;
- know the meaning of a false positive and a false negative result;
- understand why neither EPA nor HUD recommends the use of wet chemical field test kits for the identification of lead-based paint;
- explain the important criteria for identifying a proficient laboratory;
- understand the basic principles of anodic stripping voltametry (ASV);
- explain the laboratory accreditation process and why it is important in the analysis of lead.

As an inspector, this section is important to you because

- you should understand the process by which your samples are analyzed;
- you should know which analytical technique is most appropriate for analyzing your samples.



Analytical Techniques

After an inspector has collected samples, these samples must be analyzed. Most samples will be sent to a laboratory where they will undergo analytical testing for determining the presence and quantity of lead. Several techniques can be used, depending on the level of sensitivity requested and the type of sample in question. These techniques include atomic absorption spectrometry (AAS) and atomic emission spectrometry (AES).

Additionally, there are several field analytical methods that the inspector may choose to use under specific situations. These methods will also be discussed. Regardless of the method chosen, some level of sample preparation prior to analysis will be required.

Atomic Absorption Spectrometry

Atomic absorption spectrometry (AAS) is a method for elemental analysis. AAS is based on the principle that the amount of light absorbed by a gaseous form of a specific metal can be used for determining the amount of metal present. Since most samples are initially in the liquid or solid form, they must be broken down to an atomized or vaporized form. The solution can be vaporized either by a flame or a graphite furnace. Once vaporized, the atoms absorb ultraviolet (UV) or visible light and make transitions to higher electronic energy levels. The concentration of the metal is then determined from the amount of light absorbed.

Two types of AAS,

- flame atomic absorption (FAA) spectrometry, and
- graphite furnace atomic absorption (GFAA) spectrometry,

are used to detect lead in environmental samples. FAA is probably the more commonly used since it tends to be less expensive but also provides adequate sensitivity.

Both the FAA and GFAA instruments are similar in design. Basically, each has a light source (usually a hollow cathode lamp), an atomizer, and a detector. The atomizer is necessary for vaporizing the sample since AAS requires a sample to be in the gaseous phase. The atomizer is usually a higher-temperature source such as a flame or graphite furnace. FAA can be used only for analyzing solutions, but GFAA can be used for analyzing solutions, slurries, or solid samples. The FAA instrument converts samples into tiny droplets before they enter the flame.

Although the FAA instrument is usually sufficient for analyzing environmental lead samples, the GFAA has several advantages, most noticeably the higher efficiency in atomizing samples because of the increased surface area of the graphite furnace versus the flame. As a

There are several analytical methods for analyzing environmental samples for lead content.

Both FAA and GFAA are used to detect lead in environmental samples.

GFAA has a lower limit of detection than FAA, however FAA is sensitive enough for most environmental lead samples.



ICP-AES measures the amount of light emitted from a sample.

ICP-AES can be used to detect multiple metals in a single sample.

ASV is a mobile method for detecting lead in environmental samples.

result, GFAA is more sensitive than FAA. GFAA is most commonly used to analyze water samples for lead content.

The cost for environmental lead samples analyzed by FAA ranges from \$5-\$35 per sample. GFAA analysis costs are generally slightly higher, ranging from \$15-\$40 per sample.

Atomic Emission Spectrometry

Atomic emission spectrometry (AES) uses a quantitative measurement of the optical emission from excited electrons to determine the concentration of lead (or other substances) in a sample. As in AAS, the solution must be atomized. However, instead of injecting the sample into a flame or a graphite furnace, it is typically injected into a very high temperature plasma that has enough energy to cause the electrons to jump to very high energy levels. When the electrons decay back to lower energy levels, light is emitted and measured to determine which elements and how much of each are present in the sample.

The type of AES commonly used to determine the amount of lead in a sample is Inductively Coupled Plasma-Atomic Emission Spectrometry (ICP-AES). AES has one primary advantage over AAS. If an inspector is interested in identifying other metals (e.g., chromium or cadmium) in addition to lead in a single sample, AES can be used because it is a multi-element technique. In order to detect other metals in addition to lead using AAS, an inspector would have to collect and submit multiple samples.

The cost for environmental lead samples analyzed by ICP-AES ranges from \$15-\$35 per sample.

Regardless of the laboratory analytical method chosen, most laboratories will provide a significant reduction in the per sample cost when an inspector submits, or commits to submit, samples in volume.

Anodic Stripping Voltametry

Anodic stripping voltametry (ASV) is an analytical method for identifying small amounts of metals within a substance. To detect lead in paint, soil, dust, or water, the lead ions must be put into solution before analysis. Once in solution, an electric current is applied and the lead ions are attracted to an electrode, where they concentrate. After concentration, they are "stripped" from the electrode. Any metal forms of lead that occur can be analyzed, even at very low concentrations.

These systems are generally portable, analytical instruments specifically designed for analyzing suspected lead samples in either the field or the lab. The system does not utilize a radioactive source. Most systems can measure lead content in paint, air, dust, soil, and drinking water with

Sample Analysis and Laboratory Accreditation

accuracy similar to laboratory methods. Paint results can be measured in either mg/cm² or percent lead in the sample.

ASV offers inspectors an alternative approach to analyzing inconclusive XRF readings by taking a paint chip sample and testing on site. Soil, dust wipe, and water samples can also be analyzed on site in less time than sending samples off to a laboratory. The instruments include software with menu driven programs which enable the inspector to store results. Stored data can be reviewed and the results may be printed out.

The cost associated with using the ASV technology is comparable to other analytical techniques. Replacement electrodes cost approximately \$6 each (one electrode is used per sample analyzed). The instrument itself is available in various configurations which allow for testing of specific sample media (e.g, paint chips only) or several types of samples (e.g., paint chips, dust wipes, and soil). Currently, the prices range from \$2,000 to \$6,000 depending on the configuration. Since chemicals are used to process the sample for analysis, OSHA requires training in chemical handling procedures and access to eye wash equipment. Anyone using this system to analyze environmental lead samples from target housing or child-occupied facilities *must* obtain recognition under EPA's laboratory-recognition program—the National Lead Laboratory Accreditation Program (NLLAP). More information on laboratory accreditation can be found beginning on page 11-13.



Anyone using ASV must be an NLLAP-recognized laboratory in order to analyze environmental samples for lead content.



Analysis of Paint Chip Samples

When submitting paint chips for laboratory analysis, the inspector must accurately measure the dimensions of the surface of the paint chip to allow the laboratory to report the results in mg/cm^2 , as portable XRFs do. Laboratories may also report the results in percent-by-weight measurements. Percent-by-weight measurements are usually reported as micrograms per gram ($\mu\text{g}/\text{g}$) or parts per million (ppm) by weight. For example, a sample with 0.1 percent lead may be reported as 1,000 $\mu\text{g}/\text{g}$, 1,000 mg/kg , or 1,000 ppm.

For samples that require digestion, the sample should be pulverized so that adequate surface area is provided for effectively dissolving the sample prior to laboratory instrument measurement. For example, paint chips should be collected from a four-square-inch surface area. If the sample is properly homogenized and minimal substrate is included, the results can be reported in milligrams per square centimeter (mg/cm^2) or percent by weight or both.

As a reminder, if the area sampled cannot be accurately measured, the results must be reported in percent by weight and any adhering substrate will "dilute" the amount of lead as a percentage of the total weight of the sample. Therefore, it is very important to sample all the layers of paint without including any substrate. If however, the area sampled is able to be measured accurately, a small amount of substrate adhering to the paint chip sample will not affect the result when reporting the total amount of lead in mg/cm^2 .

Paint chip sample results may be reported in mg/cm^2 or percent by weight.



Analysis of Soil Samples

The inspector should label soil samples on the sample container prior to submitting them to the laboratory for analysis. The inspector must use the same numbers as those on the field sampling form and must also use the same numbers on the laboratory submittal form. The inspector should also follow chain of custody requirements.

Once soil samples are received by the lab, they are logged in, opened, placed on drying plates, dried, and mixed thoroughly. The samples are then sieved once (with a mesh size of two millimeters [mm]). Visible paint chips and other large particles are broken up by being forced through the sieve with a rubbing motion. This procedure should always be carried out under a laboratory hood. Samples are then oven dried to a constant weight and are analyzed by approved EPA or ASTM methods.

Both EPA and ASTM have methods for analyzing soil samples.

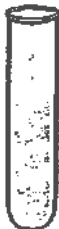

Analysis of Dust Wipe Samples

Dust wipe samples are submitted to the laboratory in the container in which they were initially collected by the inspector. For single surface samples, once the sample is received by the laboratory, the wipe is removed from the container and unfolded. The wipe is sometimes cut into small pieces and placed into a beaker, and the container is rinsed with a known amount of rinsing solution. The wipe is covered with distilled water, and concentrated nitric acid and hydrochloric acid are added. The mixture first is heated, then cooled and transferred to a larger flask. Prior to analysis by AAS or AES, an aliquot is filtered through filter paper and centrifuged. The liquid is drawn off and analyzed by AAS or AES. For composite samples, the procedure is similar.



Wet Chemical Field Test Kits

Wet chemical field test kits and chemical spot test kits are a qualitative means of detecting lead in paint. These kits are considered do-it-yourself test kits and are available to the general public for quick lead testing in paint, ceramic, or other solid materials.

Two types of test kits are currently available:

- sodium sulfide field test kits
- sodium rhodizonate field test kits.

Both kits use a chemical reagent that should change color if lead is present in amounts equal to or greater than 1.0 mg/cm² or 5000 ppm in the material being tested.

Sodium Sulfide Field Test Kits

Sodium sulfide kits consist of an aqueous solution of sodium sulfide. When this solution is placed in contact with a surface that contains lead, the solution turns a dark grey or black color. The test can also be administered if an incision is made into the painted surface such that all underlying layers of paint are exposed. A small drop of the solution is then placed into the incision. If lead is present, the solution will turn from clear to dark grey or black.

The reactant color is one of the drawbacks to using this type of test. The sodium sulfide kits are not suitable for use on any surface that is painted a dark color because the surface will turn grey or black and the change may not be visible to the inspector. Furthermore, many other metals (such as titanium, which is commonly used in nonlead-based paint) also react with sodium sulfide and can result in a false positive. These tests are also not suited for use on metal surfaces.

Sodium Rhodizonate Field Test Kits

Sodium rhodizonate field test kits consist of two chemicals that must be mixed just prior to use. This solution turns from pale yellow to pink or red when exposed to lead. This type of kit can be used in several ways to determine the presence of lead. A small slit can be cut into the painted surface and a drop of solution placed into it, similar to the method used with sulfide kits. Alternatively, the surface can be sanded and a drop of solution placed on the newly revealed surface. Finally, a plug or core of paint can be removed from the suspect material and ground up and placed into the solution. If lead is present, each sampling method should result in a pink or red color change to the initially yellow solution. If there is no color change, the test should be interpreted as negative. However, the outcome from rhodizonate kits may be affected by the

There are two types of chemical spot test kits: sodium sulfide and sodium rhodizonate.

If lead is present, sodium sulfide turns from clear to grey or black.

Sodium rhodizonate turns from pale yellow to pink or red if lead is present.

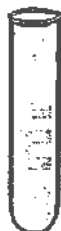

Chemical spot test kits may be used to check for lead on materials other than paint.

Neither HUD nor EPA currently recommend the use of spot test kits.

Both chemicals yield an unacceptable rate of false positives and false negatives when testing for LBP.

presence of salts on the surface of the material, resulting in a false positive.

Regardless of choice of wet chemical analysis, the user must take care that all layers of paint come in contact with the kit's chemical. For most of the kits, an incision should be made down to the substrate and the chemical can then be dropped into the incision. After a short time (ranging from seconds to several minutes), a color change will indicate the possible presence of lead in at least one layer of paint. Some kits require the user to remove a paint chip from the surface, grind it, and apply a drop of the chemical to the ground material. After waiting the required period of time, a second chemical must be added before a color change is observed.

Lead detection kits such as chemical spot test kits may be useful as a quick check for screening surfaces for lead-based paint. A positive color change suggests the presence of lead or a positive interference. However, a negative response or no color change is not conclusive evidence of the absence of lead. A more complete determination should be made by quantitative laboratory methods.

These kits offer both advantages and disadvantages to the user. Characteristics that make chemical spot test kits ideal include:

- simple and quick estimation of whether the painted or glazed (for ceramics) surface contains lead;
- materials other than paint may be tested (e.g., ceramics, lead crystal, solder, foil, pewter, and other metals);
- relatively easy to use;
- inexpensive.

EPA's and HUD's decision to *not* recommend using these kits until further research is completed is based on a number of disadvantages:

- possible interference with some materials (i.e., barium, calcium sulfate, plaster, chromate) could result in a positive color change;
- results are not quantitative and they require additional laboratory confirmation;
- users who are color-blind should not use these products.

Several research studies have examined the validity of chemical spot test kits, including a recent study by EPA and HUD that was published in May 1995 (*A Field Test of Lead-Based Paint Testing Technologies: Technical Report*, EPA-747-R-95-002b). This study concluded that test kits *should not* be used for lead-based paint testing because the kits cannot determine the extent of lead-based paint in a home or the need for protecting occupants, especially when repairs or renovations are carried out. Decisions on repairs, renovations, or abatements *should not* be based on test kit results.



Laboratory Accreditation

EPA's rules require that inspectors submit their samples to laboratories that are proficient in the analysis of environmental lead samples. There are specific methods used by the EPA-recognized laboratories to analyze Environmental Lead Proficiency Analytical Testing (ELPAT) Program samples.

A laboratory recognized by the National Lead Laboratory Accreditation Program (NLLAP) must be used for the analysis of environmental lead samples. NLLAP has been established by EPA's Office of Pollution Prevention and Toxics (OPPT) to provide the public with a list of recommended laboratories that have proven their capability for analyzing lead in paint, dust, and soil samples at the levels of concern stated in the HUD *Guidelines* and the EPA rules.

In order to participate in NLLAP, a laboratory must participate in the ELPAT program. The ELPAT program is administered by the American Industrial Hygiene Association (AIHA) in cooperation with the Centers for Disease Control and Prevention (CDC), the National Institute for Occupational Safety and Health (NIOSH), and OPPT. The ELPAT program tests laboratory proficiency by submitting samples consisting of variable levels of lead in paint, dust, and soil matrices for the laboratories to analyze. The laboratories must report their results on each ELPAT round. A laboratory's performance for each matrix (e.g., soil, paint chips, and dust wipes) is rated as proficient if their ELPAT results are within three standard deviations of the determined acceptable range for 75 percent of the ELPAT test samples.

Laboratories who want to participate in the ELPAT program do not have to be accredited by AIHA (AIHA has its own accreditation process under which a lab can achieve NLLAP recognition).

In addition to participating in the ELPAT program, a laboratory must undergo a systems audit that includes site visits to the laboratory facility. The systems audit must be conducted by an accrediting organization with a program recognized by EPA through a Memorandum of Understanding (MOU). The MOU defines certain EPA criteria to be incorporated into the accrediting organization's assessment program for the laboratory analysis of paint, dust, and soil samples for lead. These include laboratory personnel qualifications and training, analytical instrumentation, analytical methods, quality assurance, and record keeping procedures. Currently, the American Association for Laboratory Accreditation (A2LA) and AIHA have been recognized as laboratory-accrediting organizations participating in NLLAP.

An inspector can call the National Lead Information Center (NLIC) (1-800-424-LEAD) for an up-to-date, state-by-state list of laboratories recognized by EPA for analyzing paint chip, dust, and/or soil samples.

EPA's rules require inspectors to submit their samples to NLLAP-recognized laboratories.

A2LA and AIHA are the two accrediting organizations that can provide a laboratory with NLLAP-recognition.



ASTM Standards

The American Society for Testing and Materials (ASTM) has developed a number of standards relative to sample collection and analysis for lead in dust, paint, and soil samples. Below is a partial list of these ASTM standards:

- E 1613 Standard test method for analysis of digested samples for lead by inductively coupled plasma atomic emission spectrometry (ICP-AES), flame atomic absorption (FAAS), or graphite furnace atomic absorption (GFAAS) techniques
- E 1644 Standard practice for hot plate digestion of dust wipe samples for the determination of lead by atomic spectrometry
- E 1645 Standard practice for the preparation of dried paint samples for subsequent lead analysis by atomic spectrometry
- E 1726 Standard practice for sample digestion of soils for the determination of lead by atomic spectrometry
- E 1727 Standard practice for field collection of soil samples for lead determination by atomic spectrometry techniques
- E 1728 Standard practice for field collection of settled dust samples using wipe sampling methods for lead determination by atomic spectrometry techniques
- E 1729 Standard practice for field collection of dried paint samples for lead determination by atomic spectrometry techniques
- E 1753 Standard practice for the use of qualitative chemical spot test kits for detection of lead in paint films
- E 1775 Standard guide for evaluating performance of on-site extraction and field-portable electrochemical or spectrophotometric analysis for lead
- E 1792a Standard specification for wipe sampling materials for lead in surface dust
- E 1828 Guide for evaluating the performance characteristics of qualitative chemical spot test kits for lead in paint
- E 1979 Standard practice for ultrasonic extraction of paint, dust, soil, and air samples for subsequent determination of lead
- E 2051 Standard practice for determination of lead in paint, settled dust, soil, and air particulate by field-portable electroanalysis

Copies of these standards, and several others related to lead hazards in buildings, are available for purchase from ASTM, www.astm.org or (610) 832-9585.



Pb

CHAPTER 12

FIELD TRIP

Objective	12-3
Learning Tasks	12-4
Inspecting a Residence for Lead-based Paint Using the HUD Guidelines	12-5
Field Trip Instructions	12-5
Assignment	12-5



Inspecting for Lead-based Paint





Field Trip

Objective

The objective of this chapter is

- to give students an opportunity to conduct a mock lead-based paint inspection in a housing unit using the HUD inspection protocol.



Learning Tasks

After finishing this chapter inspectors should be able to

- list the seven main steps of a lead-based paint inspection.

As an inspector, this section is important to you because

- it provides an opportunity for you to conduct a lead-based paint inspection and receive feedback on your performance;
- a practicum reinforces the information provided in class.



Field Trip

Inspecting a Residence for Lead-based Paint Using the HUD Guidelines

Scenario: You are an inspector and your services have been contracted to inspect this residence/location for lead-based paint. Conduct your inspection based on the HUD *Guidelines*

Field trip instructions

When performing a lead-based paint inspection, an inspector must inventory all painted building components including those that are stained, shellacked, varnished, coated, or painted and covered with wallpaper. The areas to be inventoried should include, but are not limited to, rooms, closets, pantries, halls and part of a divided room (e.g., living room/dining room) in the *interior* of each dwelling unit to be tested. Every type of painted, varnished, and/or stained component on the *exterior* of the unit including, but not limited to siding, porches, garages, decks, patios, sheds, and boundary fences should also be tested. Additionally, the inspector must inventory every interior and exterior *common area* such as, but not limited to, stairways, laundry facilities, recreation rooms, foyers, hallways, playgrounds, and community centers.

Assignment

1. Using the attached graphing paper, diagram the interior and exterior of the dwelling, including any common areas.
2. Perform calibration checks according to the PCS.
3. Using the attached LBP Testing Data Sheets (the instructor will indicate which type of residence will be inspected [i.e., single-family or multifamily]):
 - fill out identifying information and age of construction;
 - inventory each room and select painted surfaces to be tested by identifying testing combinations.
4. Answer the following questions:
 - a. How many room equivalents did you designate?
 - b. How many testing locations did you identify in the room equivalents you tested with your instructor?
 - c. What testing combinations contain lead at or above the federal standard?



Inspecting for Lead-based Paint



Field Trip

Diagram of the interior room equivalents

Room No.	Room Name	Area (sq. ft.)	Volume (cu. ft.)	Room No.	Room Name	Area (sq. ft.)	Volume (cu. ft.)
101	101
102	102
103	103
104	104
105	105
106	106
107	107
108	108
109	109
110	110
111	111
112	112
113	113
114	114
115	115
116	116
117	117
118	118
119	119
120	120
121	121
122	122
123	123
124	124
125	125
126	126
127	127
128	128
129	129
130	130
131	131
132	132
133	133
134	134
135	135
136	136
137	137
138	138
139	139
140	140
141	141
142	142
143	143
144	144
145	145
146	146
147	147
148	148
149	149
150	150
151	151
152	152
153	153
154	154
155	155
156	156
157	157
158	158
159	159
160	160
161	161
162	162
163	163
164	164
165	165
166	166
167	167
168	168
169	169
170	170
171	171
172	172
173	173
174	174
175	175
176	176
177	177
178	178
179	179
180	180
181	181
182	182
183	183
184	184
185	185
186	186
187	187
188	188
189	189
190	190
191	191
192	192
193	193
194	194
195	195
196	196
197	197
198	198
199	199
200	200



Inspecting for Lead-based Paint





Inspecting for Lead-based Paint



CHAPTER 13

DATA EVALUATION AND REPORT PREPARATION

Objectives	13-3
Introduction	13-4
Common errors and deficiencies in inspection reports	13-4
Data Evaluation	13-6
Report Content	13-15
Inspection Report Checklist for Single-Family Dwellings	13-20
Inspection Report Checklist for Multifamily Dwellings	13-22
Recordkeeping	13-24
Required Lead Warning Statements	13-26
For More Information	13-27

Inspecting for Lead-based Paint



Data Evaluation and Report Preparation

Objectives

The objectives of this chapter are to:

- demonstrate the types of data generated during a lead-based paint inspection and how to evaluate the data;
- discuss the possible sources of error within the data;
- explain the function of the final inspection report;
- describe the five major sections of an inspection report; and
- emphasize the importance of writing reports that follow a standard format while complying with federal, state or Indian tribe requirements.

Learning tasks

After finishing this chapter inspectors should be able to:

- provide clients with an accurate and readable report documenting the results of a lead-based paint inspection;
- provide the report in a standardized format;
- inform the client, verbally and in writing, of the housing owner's legal responsibility to disclose the results of a lead-based paint inspection to tenants and prospective purchasers of the housing; and
- list the supporting documents that should be included in a final inspection report.

As an inspector, this section is important because

- accurate and comprehensive reports reduce an inspector's legal liabilities and the possibility of misunderstandings;
- EPA, state, and Indian tribe rules require inspectors to provide a report based on "documented methodologies" when conducting a lead-based paint inspection and to provide specific items in the final report; and
- well-written reports are good customer service and they present the results in a way that the client can understand and thus reduce the need to explain information to the client.

Introduction

The final product of a lead-based paint inspection is the provision of a report detailing the location and amount of lead-based paint within a dwelling or development. The focus of this chapter is to address

- data evaluation;
- report content, including federal disclosure requirements; and
- record keeping.

Common errors and deficiencies in inspection reports

The results of a study of the quality of both lead-based paint inspections and inspection reports was published in 1998². This study identified a number of deficiencies in the completeness of lead-based paint inspections and in the reports summarizing the results. Additionally, the results of a survey of certified inspectors indicated that many final reports did not contain all of the items recommended in the *Guidelines* or the EPA-model curriculum for lead-based paint inspectors. The most important errors or deficiencies included:

- did not test at least one of each of the testing combinations per room equivalent;
- did not provide enough specific information (using narrative or a sketch of the housing) so that the client or another inspector could determine exactly where the testing was conducted (i.e., which window sash, which door);
- produced a higher than acceptable rate of false negatives (calling a component negative for lead-based paint when it in fact was painted with lead-based paint);
- provided incomplete reporting of the results of an inspection.



A study of the quality of lead-based paint inspections identified a number of deficiencies in inspection reports.

² Field Evaluation of Lead-based Paint Inspections: Final Technical Report. HUD Office of Lead Hazard Control, September 30, 1998.

Data Evaluation and Report Preparation

In addition, other errors that made the reports difficult or impossible to interpret included:

- did not include definitions of key terms used in the report;
- used inconsistent and incorrect use of architectural and construction terms;
- did not attach copies of the data testing sheets or data printout from the XRF with the raw XRF data;
- did not include a statement informing the client of his/her responsibility to disclose the results of the inspection prior to sale or rental of the housing;
- did not provide information on assumptions made during the inspection (e.g., what, if any, components were assumed to be positive for lead-based paint and were not tested, reliance on previous testing data); and
- included typographical or mathematical errors during data analysis and report preparation that affected the accuracy of the report.

This chapter has been designed to address some of these deficiencies so the final inspection report contains all the information legally required by EPA and HUD, as well as provides the client with a comprehensible and complete report.

Data Evaluation

A lead-based paint inspection generates a lot of data. Before a final report summarizing the findings can be produced, the data must be evaluated to ensure that the inspection was completed in accordance with a documented methodology (such as the inspection protocol described in Chapter 7 of the *HUD Guidelines*). This data must also be evaluated and summarized to determine which components contain lead-based paint and which do not.

Analyzing the data from a single-family lead-based paint inspection is less complicated than a multifamily inspection. Therefore, data for the two types of housing inspections are presented separately in this section.



Single-family housing

The first step in data evaluation is to review the data testing sheets for each room equivalent to determine if additional testing is required. If any of the XRF readings fall into the inconclusive range for the instrument used, a paint chip should be collected to complete the classification of testing combinations (in accordance with the *Guidelines'* Chapter 7 protocol).

Additionally, any testing combinations that were not tested using an XRF analyzer because of variables such as size or shape should also be sampled and classified as positive or negative for lead-based paint. If the owner of the housing does not want any paint-chip samples collected due to either the additional cost or the destructive nature of paint-chip sampling, then those inconclusive component types (i.e., groups of like components constructed of the same substrate) in that room equivalent *should* be classified as positive.

Presuming lead-based paint

An owner may choose to assume that surfaces contain lead-based paint to reduce the costs associated with testing. He/she may choose this option if he/she expects to renovate or remodel the areas in which those testing combination(s) are located. The owner may choose to assume the housing contains lead-based paint until he/she renovates or remodels and incorporates the lead-based paint detection and hazard control into the cost of the renovation project.

When inspecting single family housing, test one of each testing combination.

All inconclusive results should be confirmed by laboratory analysis unless the client wishes to assume they are positive.

An owner can always assume surfaces are coated with lead-based paint.

Data Evaluation and Report Preparation

Once all of the XRF data has been classified as either positive or negative in relation to the 1.0 mg/cm² federal standard (or to the state or local standard, if applicable) and all paint chip sample results have been classified as positive or negative relative to the 0.5 percent by weight or 1.0 mg/cm² federal standard (or to the state or local standard, if applicable) a list of positive testing combinations should be developed. This list should include:

- room equivalent (name and number);
- component type;
- substrate type; and
- color of paint, stain or other surface coating (optional).¹

Some of the older generation XRF analyzers do not interface with a computer; therefore, all of the data provided by the instrument must be manually entered onto data forms. The newer generation analyzers include software that can interface with a desktop or laptop computer. This software will allow the inspector to print out a report that includes the test location and the lead level for each testing combination, and all other readings collected during the inspection (e.g., calibration checks). This data should be carefully reviewed for data entry errors that may have occurred in the field (e.g., XRFs with software capabilities) or in the office (e.g., older XRFs requiring manual data entry).

An inspector should review testing data to identify errors or omissions.

Multifamily housing

Multifamily housing is traditionally defined as housing that contains more than one dwelling unit per location. However, for purposes of a lead-based paint inspection only, multifamily housing is defined as any group of units that are similar in construction from unit to unit with:

- 21 or more similar units, common areas, or exterior sites if any were built before 1960 or are of unknown age, or
- 10 or more similar units, common areas, or exterior sites if they were all built from 1960 to 1977.

Developments with fewer units, common areas, or exterior sites should be treated as single-family housing.

¹ The color of paint or stain is *not* a criteria for a testing combination in the HUD protocol, however it should be included in the summary for ease of identifying the specific component tested.

When inspecting multifamily housing, at least 40 of each component type must be tested.

The inspector must complete a component type form to classify the component types into one of four classifications.

Classification of XRF Results

In multifamily housing, in addition to the items listed under single-family housing, the data generated must also be reviewed to ensure that at least 40 of each component type were tested within the units sampled. If there were fewer than 40 components of a given type in the units tested, all of the components of that type should be tested.

Once the number of each component type has been verified, the *Multifamily Housing: Component Type Report* form must be completed in order to classify the component types as either positive, negative, or inconclusive. The number and percentage of component type classified should be recorded as either:

- positive for lead-based paint relative to the federal standard (or state or local standard, if more stringent than the federal);
- inconclusive and having XRF readings less than the midpoint of the XRF's inconclusive range ("low inconclusive");
- inconclusive and having XRF readings greater than the midpoint of the XRF's inconclusive range ("high inconclusive"); or
- negative for lead-based paint relative to the federal standard (or state or local standard, if more stringent than the federal standard).

Each of these classifications is based upon the XRF Performance Characteristic Sheet for the XRF(s) used during testing. See the example multifamily component type report provided in Figure 13-2.

The percentage in each of the four groupings above are calculated by dividing the total number of that component type tested into the number that fall into each group and multiplying the result by 100. The results for each component type are then "plugged into" the Multifamily Flowchart (see Figure 13-1—Multifamily Decision Flowchart). This flowchart at first glance appears complicated, but is a logical and statistically valid way to make development-wide decisions on the lead-based paint content of components from a random sampling of the units.



Data Evaluation and Report Preparation

Figure 13-1. Multifamily Decision Flowchart

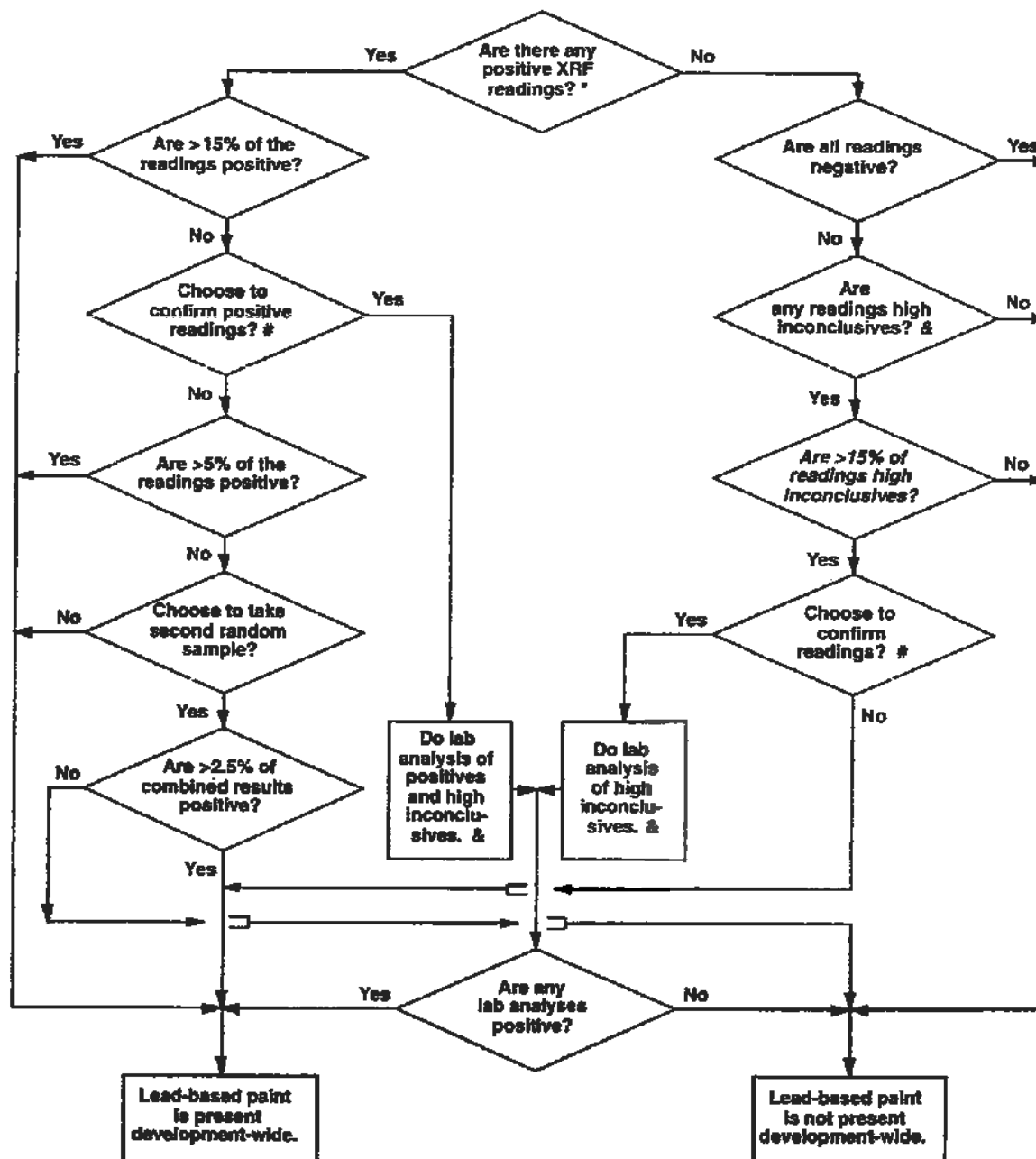

* "Positive," "negative," and "inconclusive" XRF readings are determined in accordance with the XRF instrument's *Performance Characteristics Sheet* as described in the *HUD Guidelines for the Evaluation and Control of Lead-based Paint Hazards in Housing*, Chapter 7 (rev. 1997).

& A high inconclusive reading is an XRF reading at or above the midpoint of the inconclusive range. For example, if the inconclusive range is 0.41 to 1.39, its midpoint (average) is 0.90; a reading in the range from 0.90 to 1.39 would be a high inconclusive reading.

Any paint or coating may be assumed to be lead-based paint, even without XRF or laboratory analysis. Similarly, any XRF reading may be confirmed by laboratory analysis.

Sample Exercise: Using the *Multifamily Housing: Component Type Report Form* and the *Multifamily Flowchart*

Using the completed *Multifamily Housing: Component Type Report* (Figure 13-2), the total number of component types tested must be at least 40. Once the calculations are completed for each component type—the percentage positive, low inconclusive, high inconclusive, and negative—the inspector uses the Multifamily Flowchart (Figure 13-1) to determine if each component type is positive or negative development-wide.

Here are two examples using a fictitious housing complex called *Fenway Gardens* (see Figure 13-2).

Example One:

In Fenway Gardens Housing Complex, the percentage of interior wood window sills (stools) that tested positive was 54.5 percent.

Step one: Are there any positive XRF readings? Yes.

Step two: Are ≥ 15 percent of the readings are positive? Yes.

This result directs the inspector to the bottom of the flowchart to the conclusion that “lead-based paint is present development-wide” for that component type.

Example Two:

Using the same complex, the percentage of wood shelves that tested positive was 4.8.

Step one: Are there any positive XRF readings? Yes.

Step two: Are ≥ 15 percent of the readings are positive? No.

Continuing down the flowchart, the inspector has the option of confirming positive XRF readings with laboratory analysis. In this example, the inspector chose *not* to confirm the positive XRF readings.

Step three: Are ≥ 5 percent of the readings positive? No.

Assuming the inspector chose not to take a second random sample, again the inspector is directed to the bottom of the flowchart to the conclusion “lead-based paint is present development-wide” for that component type.

Were the inspector to make different choices (e.g., choosing to confirm the positive XRF readings or to take a second random sample), the conclusion could be different depending on the results of those choices.

An inspector must review the data carefully before writing the final report.

An inspector must perform good data management of inspection results.

An inspector might serve the client better if components such as doors and windows are separated into interior vs. exterior, or common areas vs. unit areas, instead of grouping them together when using the multifamily decision tree.

Preventing mathematical or typographical errors

One way to prevent common mathematical or typographical errors on final reports is to set up a spreadsheet software program that will calculate all of the results as they are entered into the program. Many newer generation XRF analyzers come with software to conduct these calculations. However, the inspector must still review the data carefully because typographical errors can occur during data entry. Training in the software is essential to prevent other errors when setting up the spreadsheet (e.g., not including all the "cells" in the formula, using incorrect formulae).

Fenway Gardens Housing Complex				
Sample number	Component	Substrate	XRF result	Classification
81699-101	Door jamb B	Metal	3.4	Pos
81699-102	Door A	Metal	4.1	Pos
81699-103	Baseboard C	Wood	3.5	Pos
81699-104	Window sill D-1	Wood	4.6	Pos
81699-105	Window sash D-2	Wood	5.4	Pos
81699-106	Crown (A)	Wood	3.1	Pos
81699-107	Wall A	Plaster	0.2	Neg
81699-108	Wall B	Plaster	0.1	Neg
81699-109	Wall C	Plaster	0.2	Neg
81699-1010	Wall D	Plaster	0.3	Neg

The various XRF manufacturers have each incorporated different capabilities for setting lead concentration thresholds and other data sorting features. Data management will depend on these capabilities, client needs, and the facilities being inspected. An inspector's ability to perform good data management of inspection results is essential, especially for inspections in multifamily properties.

Example software spreadsheet layout.

Development-wide summary

Once each component type has been classified as positive or negative for lead-based paint, a development-wide summary must be generated. This summary should include each component type that contains lead-based paint at or in excess of the federal standard. It should also include a list of any components (by type and unit number) that were found to contain lead-based paint, but were not found development-wide. (Remember that if the inspector chooses to confirm positive readings or high inconclusive

The development-wide summary is not designed to indicate the location of all lead-based paint within a development.

Data Evaluation and Report Preparation

readings, if one paint chip sample comes back positive for lead-based paint, that component type is positive development-wide.)

It is important to remember that the development-wide summary is not designed to locate all lead-based paint within a development, but rather to give the owner information as to whether to continue testing or assume lead-based paint is present on specific component types based on the random sample data set.

The outcome of the decision tree conclusion that says "lead-based paint is present development-wide" is based on the statistical foundation of the multifamily protocol. The foundation presumes that the number of units tested according to the random testing table is adequate (at least 95% of the time) to find at least one location that has lead-based paint if lead-based paint was applied on a systematic basis in some portion of the development. However, because the decision tree is set up so that only one confirmed positive leads to the conclusion that "lead-based paint is present development-wide," the statistical foundation cannot account for units that have been painted on a non-systematic basis, for example, by the unit occupant. If random testing happens to be performed in one individual unit that was painted with lead-based paint, property management may incorrectly conclude that lead-based paint is actually present development-wide.

On the other hand, if random testing is *not performed* in that particular unit, property management will reach the conclusion that "lead-based paint is not present development-wide." If property management does not understand the random sampling protocol (like most people) they may think that this conclusion means there is no lead-based paint in the development at all. This may lead to incorrect disclosure to occupants.

Therefore, the random testing protocol is more likely to provide correct conclusions in property where painting has always been done by property management, which tends to be systematic.

Abbreviation of testing

In housing where similar building component types with identical substrates (for example, wood window systems throughout the dwelling) are all found to contain lead-based paint within the first five interior room equivalents, the HUD *Guidelines* protocol allows the inspector to stop testing *that component type*. (The reverse is not allowed—if the wood windows in the first five rooms do not contain lead-based paint, the inspector *cannot* assume that the remaining windows are not painted with lead-based paint.)

The inspector must obtain the client's permission to abbreviate the testing before discontinuing testing. The inspector should outline the advantages and disadvantages of abbreviating testing to the client. Advantages include:

Abbreviation of testing is allowed under specific circumstances.

The inspector must obtain the client's permission before abbreviating testing.

Inspecting for Lead-based Paint

- reduced inspection costs for the client by not testing components likely to contain lead-based paint; and
- allow time saved on testing to be spent on communicating the results and their meaning or implications to the client.

Disadvantages include:

- possibility of misidentifying a component as coated with lead-based paint when it is not; and
- additional expense of treating a component as a lead-based paint hazard when it may not be.

If the client agrees, this agreement must be clearly spelled out in the scope of services for the project *before* beginning the inspection. Also, a statement should be included in the final report that testing was stopped and any untested components of that type in the remaining rooms were *assumed* to contain lead-based paint.

This testing reduction strategy may also be applied to multifamily housing, *however*, the inspector must test at least 40 of each component type before attempting to classify that component as positive or negative for lead-based paint. Therefore, it is most logical to test all components in all units *until* the 40 threshold has been reached for each component type. That component type in subsequent units would not have to be tested. The inspector will need to evaluate the abbreviation strategy for each development carefully. Remember, an inspector may never assume negative. Even if the universe of a particular component type is very large, if one test is positive, and the inspector chooses not to take a second random sample, lead-based paint is present development-wide on that component type.

Data Evaluation and Report Preparation

Report Content

Regardless of the type of housing inspected, each inspection report should include the following sections:

- cover letter or summary page;
- scope of service, including any limitations or exclusions;
- supporting documents and appendices; and
- disclaimer.

Each of these sections is discussed below, followed by checklist for single and multifamily dwellings.

Cover letter or summary page

The cover letter or summary page should answer two basic questions regarding the lead-based paint inspection:

- Is lead-based paint present in the unit or dwelling?
- If lead-based paint is present, where is it located?

In order to answer these two questions completely, some basic information about who conducted the inspection, when it was conducted, for whom, and how was it conducted must be included at the beginning of the report. Below is a list of the identifying information that should be included:

1. Inspection site address;
2. Client's name, address, and phone number;
3. Inspector's information:
 - name and license/certification information
 - firm name and license/certification information;
4. Date(s) of the inspection;
5. Start and stop times for the inspection each day;
6. Protocol followed during the inspection (e.g., HUD 1997 inspection protocol);
7. XRF analyzer make, model, serial number, and source date;
8. A statement informing the client of his/her legal obligation to disclose the results of the lead-based paint inspection to prospective tenants or purchasers of the housing *before* they become obligated under contract (the wording that must be included in the sales or rental contract is included at the end of this section);

The *Guidelines* and EPA rules establish minimum report content.

Inspecting for Lead-based Paint

A statement regarding the federal disclosure requirements should be included on the summary page of the report.

Define key technical terms and units of measure used in the report.

The report must include specific locations and results of each painted component tested.

Sample language for this statement:

“A copy of this summary must be provided to new tenants and purchasers of this property under Federal law (24 CFR part 35 and 40 CFR part 745) before they become obligated under a lease or sales contract. The complete report must also be provided to new purchasers and made available to new tenants. Landlords and sellers are also required to distribute an educational pamphlet and include standard warning language in their leases or sales contracts to ensure that parents have the information they need to protect their children from lead-based paint hazards.”

If the inspection found no lead-based paint, additional language should be provided informing the owner of the property that the federal disclosure requirements no longer apply *as long as* the property is available for lease; should the owner put the property up for sale, the disclosure requirements again apply.

9. Key terms and definitions relevant to the inspection and the results (may refer the client to an appendix that contains a short list of terms, units of measure, and their definitions);
10. Reference to a review of any previous testing data or reports (if made available);
11. A statement regarding the quality control procedures used during the inspection (calibration checks);
12. A statement regarding the abbreviation of testing (if applicable);
13. A list of positive testing combinations including:
 - room equivalent
 - building component
 - substrate type
 - color (optional)
 - lead level in mg/cm² or percent;
14. A list of components that were assumed to be positive and were not tested;
15. Summary interpretive language and guidance based on the inspection results;
16. A statement certifying the accuracy of the inspection report followed by the inspector's signature and date.

Sample language:

“The work performed in conjunction with this inspection and any specific limitations or exclusions as set forth in section [scope of services section of the report] and the data developed are intended as a

Data Evaluation and Report Preparation

description of available information at the dates(s) and location(s) given.”

Multifamily inspection reports should also include:

- an explanation of how units, common areas, and exterior sites were selected for testing;
- development-wide lead-based paint results; and
- unit specific results (those testing combinations that are not development-wide, but that were found to contain lead-based paint in specific units).

It is very important that the cover letter does not contain any information which is not included in the body of the report. Often times, the cover letter or summary page is separated from the main report and used on its own. There could be legal ramifications if both the cover letter and the full report do not include the same information.

Scope of service

A proposal to conduct a lead-based paint inspection should include a description of the work to be done for the client. This section of the proposal is referred to as a *scope of service* (also called a *statement of work* or *scope of work*). The scope of service section should also outline what the client is expected to provide (e.g., access to all structures on the property being inspected, notice to tenants beforehand informing them what is being done, explanation of why the property is being inspected, and the date(s) of the inspection). This same section is repeated in the final report to reiterate what was contracted to be done.

In the final report, an inspector may also include any exceptions to the scope of service. These exceptions refer to what actually happened in the field and what the inspector was not able to do and why. If any testing combinations were not tested for any reason (e.g., inaccessibility) a statement indicating what testing combinations were not tested must be included in the summary report. If permission was obtained from the client and testing was abbreviated after inspecting the first five room equivalents, as allowed by the HUD inspection protocol, that fact should be clearly stated in this section.

Other examples of exceptions to the scope of work include:

1. An inspection firm contracts to conduct a complete lead-based paint inspection in a single-family home in accordance with the HUD inspection protocol. However, when the certified inspector visited the site, the bathroom was structurally unsafe and he/she was unable to inspect surfaces within the bathroom. An exception to the scope of work could include the statement “The bathroom (room equivalent number xx) was not perceived to be safe due to structural damage

Multifamily reports must also include development-wide and unit-specific results.

The scope of service section of the report outlines the who, what, and where of the inspection process.

(i.e., rotted floor boards) and was not inspected. Therefore, based on visual reconnaissance only, it should be assumed that the painted/stained surfaces within the bathroom may contain lead-based paint.”

2. An inspection firm contracts to conduct a complete lead-based paint inspection in a multifamily development in accordance with the HUD inspection protocol. However, when the certified inspector visited one of the randomly selected units, tenants remained in the unit and would not allow access to one bedroom (Room #5). An exception to the scope of work could include the statement

“The inspection results for unit #438-A do not include any testing of surfaces within room equivalent XX (master bedroom). One of the occupants of the unit would not allow our inspector access to that room. Therefore, it should be assumed that all painted or stained surfaces within that bedroom may contain lead-based paint until testing is conducted.”

The report should include a brief discussion of the assumptions used in conducting the lead-based paint inspection and in determining its scope. The inspector should include a discussion of any procedure(s) not utilized under the scope of work and the rationale for the omission. An example of this is if a client or housing owner will not allow paint-chip sampling to be conducted during the inspection. This may occur when an inspection is being done for a prospective buyer prior to purchasing a dwelling. Therefore, any inconclusive XRF results cannot be confirmed and must be assumed positive until paint chip samples are collected and analyzed. Additionally, if no destructive sampling is allowed by the client, substrate correction values cannot be determined unless bare areas of substrate are available and acceptable to both parties. The HUD protocol and the PCS for some XRF instruments establish a specific method for conducting substrate correction; if an inspector deviates from this protocol, it must be clearly noted in this section of the report. Make sure the client is aware that if no substrate correction is allowed, all readings less than 4.0 mg/cm² will be assumed positive.

All raw XRF data and laboratory results must be included in the final report.

Supporting documents or appendices

In addition to a cover letter or summary page, the final inspection report should include as supporting documents or appendices copies of

- all the raw XRF data (either the printout from the XRF software or the testing data sheets filled out onsite);
- the laboratory results on laboratory forms from a laboratory that is recognized by the National Lead Laboratory Accreditation Program (NLLAP);
- completed calibration check form(s);

Data Evaluation and Report Preparation

- completed substrate correction form(s) (if applicable);
- a sketch or diagram illustrating room equivalents and the locations of testing/sampling; and
- the lead hazard information pamphlet *Protect Your Family from Lead in Your Home* (optional).

Additionally for multifamily housing, attach the following:

- copies of *Multifamily Housing: Component Type Report* forms (or equivalent); and
- copies of unit selection forms (also used for selecting common areas and exterior sites)

Disclaimer and standard of care

This section of the inspection report includes a brief narrative about the site and the type of inspection conducted. In addition, this section should list the protocol used and any other information relied upon to generate this final report, including:

- copies of previous lead-based paint inspections, EBL investigations, or risk assessments; and
- information provided by the owner or tenant regarding renovations or previous lead-based paint hazard control activity that occurred.

This section of the report should also include a statement advising the client that those surfaces that do not contain lead-based paint at or above the federal standard (or state or local standard, if applicable) may still pose a hazard if disturbed. In addition, the inspector should include a statement informing the client that the Occupational Safety and Health Administration (OSHA) has regulations covering worker safety and health that may apply when any painted surfaces (whether lead-based paint or not) are disturbed. (Note: OSHA does not accept XRF results to determine if lead is *not* present in a coating.)

EPA's prerenovation notification rule requires that for any renovation or remodeling project which may disturb more than two square feet of paint in a dwelling built before 1978, the contractor must provide a copy of the booklet *Protect Your Family From Lead in Your Home*.

Any disclaimer should also note that the results of any inspection are only applicable to the dwelling inspected on the date(s) indicated and that future activities at the dwelling may alter the results.

Include protocol used and any other information relied upon to generate the final report.

Inspection Report Checklist for Single-Family Dwellings

These checklists may help to ensure the completeness of the inspector's report.

Cover letter or summary:

- full address of property and unit (if applicable)
- client's address and telephone number
- name, address, and telephone number of both lead-based paint inspector and firm
- certification/license number of both lead-based paint inspector and firm
- federal disclosure statement
- definitions of key terms and units of measure
- documents reviewed (if applicable)
- statement regarding abbreviation of testing (if applicable)
- list of positive components by room equivalent
- list of components assumed to be positive
- summary interpretive language and guidance
- statement certifying the accuracy of the inspection report, signed and dated

Basic inspection information:

- date(s) of lead-based paint inspection(s) and start and stop time(s)
- description of procedures used or reference to documented methods
- make, model, serial number, and source date for XRF machine (if applicable)
- description of quality control procedures for XRF machine and calibration data

Scope of service:

- exceptions to the scope of service (if applicable)

Supporting documents or appendices:

- raw XRF data and laboratory results from an NLLAP-recognized lab
- brief explanation of forms used and their purpose
- completed calibration check form(s)
- completed substrate correction forms(s), if applicable
- copy of XRF analyzer PCS

Data Evaluation and Report Preparation

- field sketch or diagram of the property, or other means of identification
- copy of *Protect Your Family from Lead in Your Home* (optional)

Disclaimer and standard of care

Inspection Report Checklist for Multifamily Dwellings**Cover letter or summary:**

- full address of property and unit (if applicable)
- client's address and telephone number
- name, address, and telephone number of both lead-based paint inspector and firm
- certification/license number of both lead-based paint inspector and firm
- federal disclosure statement
- definitions of key terms and units of measure
- list of documents reviewed (if applicable)
- statement regarding abbreviation of testing (if applicable)
- explanation of how units, common areas, and exterior sites were selected for testing
- list of component types determined to be positive development-wide
- list of component types in the development assumed to be positive
- list of units, common areas, and exterior sites in which specific testing combinations were found to be positive, but on which lead-based paint was not present development-wide
- summary interpretive language and guidance
- statement certifying the accuracy of the inspection report, signed and dated

Basic inspection information:

- date(s) of lead-based paint inspection(s) and start and stop time(s)
- description of procedures used or reference to documented methods
- make, model, serial number, and source date for XRF machine (if applicable)
- description of quality control procedures for XRF machine and calibration data

Scope of service:

- exceptions to the scope of service

Supporting documents or appendices:

- raw XRF data and laboratory results from an NLLAP-recognized lab
- brief explanation of forms used and their purpose

Data Evaluation and Report Preparation

- completed calibration check form(s)
- completed substrate correction forms(s) (if applicable)
- copy of XRF analyzer PCS
- completed unit selection forms (include common areas and exterior sites selection forms)
- completed *Multifamily Housing: Component Type Report* forms
- field sketch or diagram of development including common areas and exterior sites, or other means of identification
- copy of *Protect Your Family from Lead in Your Home* (optional)

Disclaimer and standard of care

Recordkeeping

One of the major responsibilities of the inspector is to keep detailed records. The forms developed for the HUD *Guidelines* have been included within the relevant chapters of this curriculum. (These forms are sample forms; inspectors are encouraged to develop forms suited to their company's needs. However, any form used should include at least this same information.)

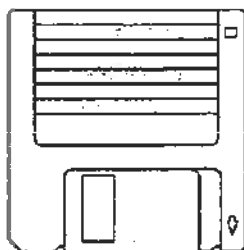

Two possible methods of data documentation are recommended. One method for recording XRF readings is to use handwritten forms, such as the complete set of forms provided in the HUD *Guidelines* or comparable forms. However, handwritten data collection can result in transcription errors; therefore, handwritten forms should be examined for missing data and copying errors. The other method of data collection is to utilize electronic storage. This method

is recommended only if sufficient data are recorded to allow another person to find the test location that corresponds to each XRF reading. Caution should be exercised when using electronic data collection due to potential loss of data. The *Guidelines* recommend examining on a daily basis "hard-copy" listings of the electronically stored data for extraneous symbols or missing data, including missing test location identification.

Always remember to backup electronic data.

Data management

As mentioned earlier in this chapter, large data sets are generated during lead-based paint inspections, especially in multifamily housing. A spreadsheet software program can be designed for handling large data sets and analyzing the data for development-wide patterns. Training on setting up and using these databases is critical for successful data management.

Records retention

Records generated during an environmental investigation, including a lead-based paint inspection, should be maintained for as long as the potential exists for questions to be raised regarding the quality, extent, and results of the inspection. In simple terms, records—including graphics or drawings—should be kept for at least as long as the structure is standing, and maybe even forever. Even after the structure is demolished and the waste has been placed in a landfill, the potential exists for issues to be raised regarding the lead content of the painted surfaces. However, legal advisors may suggest a shorter, less open-ended record maintenance policy.

Data Evaluation and Report Preparation

The EPA rules (40 CFR part 745) require all reports or plans be maintained by the certified firm or individual who prepared the report for no less than three years. The standard for record retention used by many consulting firms is based on the requirements of the Internal Revenue Service (IRS) which in practical terms is at least five years. Legal advice should be consulted in order to establish a record retention policy that adequately protects the inspector and his/her firm.

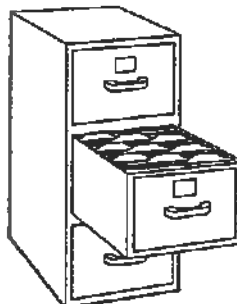

EPA requires that inspection reports be kept for at least three years.

Required Lead Warning Statements**Target Housing Sales Contracts****DISCLOSURE OF INFORMATION ON LEAD-BASED PAINT AND/OR
LEAD-BASED PAINT HAZARDS****Lead Warning Statement**

Every purchaser of any interest in residential real property on which a residential dwelling was built prior to 1978 is notified that such property may present exposure to lead from lead-based paint that may place young children at risk of developing lead poisoning. Lead poisoning in young children may produce permanent neurological damage, including learning disabilities, reduced intelligence quotient, behavioral problems, and impaired memory. Lead poisoning also poses a particular risk to pregnant women. The seller of any interest in residential real property is required to provide the buyer with any information on lead-based paint hazards from risk assessments or inspections in the seller's possession and notify the buyer of any known lead-based paint hazards. A risk assessment or inspection for possible lead-based paint hazards is recommended prior to purchase.

Target Housing Lease Contracts**DISCLOSURE OF INFORMATION ON LEAD-BASED PAINT AND/OR
LEAD-BASED PAINT HAZARDS****Lead Warning Statement**

Housing built before 1978 may contain lead-based paint. Lead from paint, paint chips, and dust can pose health hazards if not managed properly. Lead exposure is especially harmful to young children and pregnant women. Before renting pre-1978 housing, lessors must disclose the presence of known lead-based paint and/or lead-based paint hazards in the dwelling. Lessees must also receive a federally approved pamphlet on lead poisoning prevention.

Data Evaluation and Report Preparation

For More Information

These publications and organizations can provide more information on the topics covered in this chapter.

The Guidelines for the Evaluation and Control of Lead-based Paint Hazards in Housing, 1995 (rev. 1997), U.S. Department of Housing and Urban Development.

Lead; Requirements for Lead-Based Paint Activities in Target Housing and Child-Occupied Facilities; Final Rule, 40 CFR Part 745, U.S. Environmental Protection Agency, 1996.

Federal agencies

Consumer Product Safety Commission (CPSC)
Washington, DC 20207-0001
800-638-2772
Web site: www.cpsc.gov

Department of Housing and Urban Development (HUD)
Office of Lead Hazard Control
451 7th Street, S.W.
Washington, DC 20410
202-755-1785
Web site: www.hud.gov/lea

Department of Labor
Occupational Safety and Health Administration (OSHA)
200 Constitution Avenue, N.W.
Washington, D.C. 20210
202-693-2000
Web site: www.osha.gov

Environmental Protection Agency (EPA)
Office of Pollution Prevention and Toxics
401 M Street, S.W.
Washington, DC 20460-0003
202-260-2090
Web site: www.epa.gov/lead

Nongovernmental organizations

American Association for Laboratory Accreditation (A2LA)
5301 Buckeystown Pike, Suite 350
Frederick, MD 21704
301-644-3248
Web site: www.a2la.org

Inspecting for Lead-based Paint

American Industrial Hygiene Association (AIHA)
2700 Prosperity Ave., Suite 250
Fairfax, Virginia 22031
703-849-8888
Web site: www.aiha.org/lead.html

American Society for Testing and Materials (ASTM)
100 Barr Harbor Drive
West Conshohocken, Pennsylvania, 19428-2959
610-832-9585
Web site: www.astm.org

Environmental Information Association (EIA)
2915 Auburn Ave., Suite 303
Bethesda, Maryland 20814
301-961-4999
Web site: www.eia-usa.org

National Conference of State Legislatures (NCSL)
Denver Office: Washington Office:
1560 Broadway, Suite 700 444 North Capitol St, N.W., Suite 515
Denver, CO 80202 Washington, D.C. 20001
303-830-2200 202-624-5400
Web site: www.ncsl.org

National Lead Assessment and Abatement Council (NLAAC)
P.O. Box 535
Olney, Maryland 20830
800-590-6522

National Lead Information Center Hotline
800-424-LEAD
Web site: www.epa.gov/opptintr/lead/nlic.htm

The Lead Listing
888-LEADLIST
Web site: www.leadlisting.org

Data Evaluation and Report Preparation





CHAPTER 14

GLOSSARY



Inspecting for Lead-based Paint

A2LA	American Association for Laboratory Accreditation.
Abatement	any measure or set of measures designed to permanently eliminate lead-based paint hazards.
Accessible surface	an interior or exterior surface accessible for a young child to mouth or chew, such as a window sill.
Accreditation	a formal recognition that an organization, such as a laboratory, is competent to carry out specific tasks or types of tests.
Accuracy	the degree of agreement between an observed value and an accepted reference value (a "true" value); a data quality indicator. Accuracy includes a combination of random errors (precision) and systematic errors (bias) due to sampling and analysis.
Action level	the level at which an employer must begin certain compliance activities outlined in the OSHA lead standard. The action level, regardless of respirator use, for the lead in construction standard is an airborne concentration of 30 $\mu\text{g}/\text{m}^3$ calculated as an 8-hour TWA.
Acute effect	severe or immediate reaction, usually to a single large exposure.
Adequate quality control	means a plan or design which ensures the authenticity, integrity, and accuracy of samples, including dust, soil, and paint chip or paint film samples. Adequate quality control also includes provisions for representative sampling.
AIHA	American Industrial Hygiene Association
Anodic stripping voltametry (ASV)	an analytical method for identifying small amounts of metals within a substance. The ions of the metal in a solution are attracted to an electrode where they concentrate. After concentration, they are "stripped" from the electrode and measured.
Apron	a wood finish piece under a window sill, in the corner formed at the wall surface.



Glossary

- Atomic absorption** a method of measuring elements such as lead. The lead is vaporized at high temperature, usually several thousand degrees, and light of a very specific wavelength is shined through the vapor. If lead is present the light is partially extinguished. The instrument converts this change into a number that describes how concentrated the lead is in the test material.
- Balusters** the closely spaced vertical members in a stairway or balcony railing.
- Balustrade** a stairway or balcony railing consisting of *balusters*.
- Baseboard** a wood finish piece along and flat against the bottom of a wall to hide the joint between the wall and floor and to protect the base of the wall against damage.
- Base shoe** a wood molding, usually one-quarter round, nailed into the joint between a floor and a baseboard.
- Bias** a systematic error in the measurement process. For XRF readings, one source of bias is the substrate effect.
- Biological monitoring** the analysis of a person's blood and/or urine, to determine the level of a contaminant, such as lead, in the body.
- Blank** a non-exposed sample of the medium being used for testing (i.e., wipe or filter) that is analyzed to determine if the medium has been contaminated with lead (e.g., at the factory or during transport).
- Blind sample** a subsample submitted for analysis with a composition and identity known to the submitter but not to the analyst; used to test the analyst's laboratory proficiency in conducting measurements. (See also *spike sample*).
- Building component** any element of a building that may be painted or have dust on its surface, e.g., walls, stair treads, floors, railings, doors, and window sills.
- Capital** the topmost member, usually decorated, of a column, pilaster, anta, etc.

Inspecting for Lead-based Paint



Casing	a wood finish piece placed around the inside of a door or window opening.
Certified	the designation for contractors who have completed training and other requirements to allow them to safely undertake risk assessments, inspections, or abatement work.
Certified firm	a company, partnership, corporation, sole proprietorship, association, or other business entity that performs lead-based paint activities to which a state agency or EPA has issued a certificate of approval.
Certified inspector	an individual who has been trained by an accredited training program and certified by a state agency or by EPA to conduct inspections. A certified inspector also samples for the presence of lead in dust and soil for the purposes of abatement clearance testing.
Certified abatement worker	an individual who has been trained by an accredited training program and certified by a state agency or by EPA to perform abatements.
Certified project designer	an individual who has been trained by an accredited training program and certified by a state agency or by EPA to prepare abatement project designs, occupant protection plans, and abatement reports.
Certified risk assessor	an individual who has been trained by an accredited training program and certified by a state agency or by EPA to conduct risk assessments. A risk assessor also samples for the presence of lead in dust and soil for the purposes of abatement clearance testing.
Certified supervisor	an individual who has been trained by an accredited training program and certified by a state agency or by EPA to supervise and conduct abatement projects, and to prepare occupant protection plans and abatement reports.
Chair rail	a wooden protective strip placed horizontally along a wall to prevent damage from chairs striking the wall.



Glossary

- CFR—The Code of Federal Regulations** a codification of the regulations of the various federal agencies.
- Chalking** the photo-oxidation of paint binders—usually due to weathering—that causes a powder to form on the film surface.
- Characteristics** EPA has identified four characteristics of a hazardous waste: ignitability; corrosivity; reactivity; and toxicity. Any solid waste that exhibits one or more of these characteristics is classified as a hazardous waste under RCRA.
- Chelation therapy** the medical treatment in which a drug that is attracted to metals (such as lead) is infused into a patient's vein. The drug binds to the metal in the blood, and both are excreted by the kidney in urine.
- Chewable surface** an interior or exterior surface painted with lead-based paint that a young child can mouth or chew. A chewable surface is the same as an "accessible surface" as defined in 42 U.S.C. 4851b(2). Hard metal substrates and other materials that cannot be dented by the bite of a young child are not considered chewable.
- Child-occupied facility** a building, or portion of a building, constructed prior to 1978, visited regularly by the same child, six years of age or under, on at least two different days within any week (Sunday through Saturday period), provided that each day's visit lasts at least three hours and the combined weekly visit lasts at least six hours, and the combined annual visits last at least 60 hours. Child-occupied facilities may include, but are not limited to, day-care centers, preschools and kindergarten classrooms.
- Chronic effect** a response to exposure which may take days, months or years to develop.
- Clearance examination** visual examination and collection of environmental samples by an inspector or risk assessor and analysis by an accredited laboratory upon completion of an abatement project, interim control intervention, or maintenance job that disturbs lead-based paint.



Inspecting for Lead-based Paint

Clearance levels	values that indicate the maximum amount of lead permitted in dust on a surface following completion of an abatement activity.
cm	centimeter; 1/100 of a meter.
Code of Federal Regulations (CFR)	a codification of the regulations of the various federal agencies.
Common area	a portion of a building that is generally accessible to all occupants. Such an area may include, but is not limited to, hallways, stairways, laundry and recreational rooms, playgrounds, community centers, garages, and boundary fences.
Competent person	one who is capable of identifying existing and predictable lead hazards in the surroundings or working conditions and who has the authority to take prompt corrective measures to eliminate them.
Component or building component	specific design or structural elements or fixtures of a building, residential dwelling, or child-occupied facility that are distinguished from each other by form, function, and location. These include, but are not limited to, interior components such as: ceilings, crown molding, walls, chair rails, doors, door trim, floors, fireplaces, radiators and other heating units, shelves, shelf supports, stair treads, stair risers, stair stringers, newel posts, railing caps, balustrades, windows and trim (including sashes, window heads, jambs, sills or stools and troughs), built in cabinets, columns, beams, bathroom vanities, counter tops, and air conditioners; and exterior components such as: painted roofing, chimneys, flashing, gutters and downspouts, ceilings, soffits, fascias, rake boards, cornerboards, bulkheads, doors and door trim, fences, floors, joists, lattice work, railings and railing caps, siding, handrails, stair risers and treads, stair stringers, columns, balustrades, window sills or stools and troughs, casings, sashes and troughs, and air conditioners.
Composite sample	a single sample made up of individual subsamples. Analysis of a composite sample produces the arithmetic mean of all subsamples.



Glossary

Containment	a process to protect workers and the environment by controlling exposures to the lead-contaminated dust and debris created during an abatement.
Cornice	a decorative element projecting from a wall, at or near the roof line.
Deciliter (dL)	the unit of measure for blood lead levels. The prefix "deci-" means "one-tenth." One deciliter is roughly the same as about one-tenth of a quart, or about 3.4 fluid ounces.
Detection limit	the minimum amount of a substance that can be reliably measured by a particular method.
Deteriorated paint	paint that is cracking, flaking, chipping, peeling, or otherwise separating from the substrate of a building component.
Direct-reading XRF	an analyzer that provides the operator with a display of lead concentrations calculated from the lead K X-ray intensity without a graphic of the spectrum usually in mg/cm ² .
Distinct painting history	the application history, as indicated by its visual appearance or a record of application, over time, of paint or other surface coatings to a component or room.
Door casing	see <i>casing</i>
Door jamb	the sides of a door opening
Door stop	a small wood or metal strip around the inside of a <i>door jamb</i> against which a door closes.
Drywall	refers to a wall covering of <i>gypsum board</i> or similar "dry" sheets as opposed to <i>plaster</i> which is applied "wet."
Dust removal	a form of interim control that involves initial cleaning followed by periodic monitoring and recleaning, as needed.
Dwelling unit	the room or group of rooms within a residential premises used or intended for use by one family or household for living, sleeping, cooking and eating.



EBL child	See <i>elevated blood lead level (EBL)</i> .
Efflorescence	the salt rising to the surface of a material, such as masonry, plaster, or cement, caused by the movement of water through the material. Paint or encapsulants may not adhere to a surface contaminated with efflorescence.
Elevated blood lead level (EBL)	an excessive absorption of lead that is a confirmed concentration of lead in whole blood of 20 µg/dL (micrograms of lead per deciliter of whole blood) for a single venous test or of 15-19 µg/dL in two consecutive tests taken three to four months apart.
Environmental intervention blood lead level (EIBLL)	a confirmed concentration of lead in whole blood equal to or greater than 20 µg/dL (micrograms of lead per deciliter) for a single venous test or of 15-19 µg/dL in two consecutive tests taken at least three months apart.
Encapsulant	a substance that forms a barrier between lead-based paint and the environment using a liquid-applied coating (with or without reinforcement materials) or an adhesively bonded covering material.
Encapsulation	the application of an encapsulant.
Enclosure	the use of rigid, durable construction materials that are mechanically fastened to the substrate in order to act as a barrier between lead-based paint and the environment.
EPA	the United States Environmental Protection Agency.
Evaluation	risk assessment, paint inspection, reevaluation, investigation, clearance examination, or lead hazard screen.
Expected to reside	there is actual knowledge that a child will reside in a dwelling unit reserved for the elderly or designated exclusively for persons with disabilities. If a resident woman is known to be pregnant, there is actual knowledge that a child will reside in the dwelling unit.



Glossary

Exposure monitoring	the personal air monitoring of an employee's breathing zone to determine the amount of contaminant (e.g., lead) to which he/she is exposed.
Fascia	the exposed vertical edge of a roof.
Fascia board	a board that is nailed vertically to the ends of roof rafters; sometimes supports a gutter.
Federal Register (FR)	a document published daily by the federal government that contains either proposed or final regulations or notices.
Federally owned	residential property owned or managed by a Federal agency, or property for which a Federal agency is a trustee or conservator
Field blank	a clean sample of the matrix (e.g. filter or wipe) that has been exposed to the sampling conditions, returned to the laboratory, and analyzed as an environmental sample.
Fluorescence	see <i>X-ray fluorescence</i>
Friction surface	an interior or exterior building surface subject to abrasion or friction, such as a window or stair tread.
Generator	any person whose act or operation produces hazardous waste identified or listed in 40 CFR Part 261 or whose act causes a hazardous waste to come under regulation (40 CFR 260.10).
Gamma radiation	electromagnetic radiation emitted by radioactive decay and having energies in a range overlapping that of the highest energy X-rays.
Hazardous waste	any waste as defined in 40 CFR 261.3 (RCRA). RCRA's definition means a solid waste, or combination of solid wastes, which, because of its quantity, concentration, or physical, chemical, or infectious characteristics, may (a) cause or significantly contribute to an increase in mortality or an increase in serious irreversible or incapacitating reversible, illness, or (b) pose a substantial present or potential hazard to human health or the environment or when improperly treated, stored, transported, or disposed of, or otherwise managed.



Inspecting for Lead-based Paint

Heat gun	a device capable of heating lead-based paint causing it to separate from the substrate.
HEPA or high efficiency particulate air filter	a filter capable of filtering out particles of 0.3 microns or greater from a body of air at 99.97 percent efficiency or greater.
Housing for the elderly	retirement communities or similar types of housing reserved for households composed of one or more persons 62 years of age or more, or other age if recognized as elderly by a specific Federal housing assistance program.
Housing receiving Federal assistance	housing which is covered by an application for HUD mortgage insurance, receives housing assistance payments under a program administered by HUD, or otherwise receives more than \$5,000 in project-based assistance under a Federal housing program administered by an agency other than HUD.
HUD	the United States Department of Housing and Urban Development.
Impact surface	an interior or exterior building surface that is subject to damage by repeated sudden force, such as certain parts of door frames.
Inspection	a surface-by-surface investigation to determine the presence of lead-based paint and the provision of a report explaining the results of the investigation.
Indian Housing Authority (IHA)	a public housing agency established (a) by exercise of a tribe's powers of self-government independent of state law, or (b) by operation of state law providing specifically for housing authorities of Indians.
Indian tribe	a tribe as defined in the Native American Housing Assistance and Self-Determination Act of 1996 (25 U.S.C. 4101 et seq.)
Industrial hygienist	a person having a college or university degree in engineering, chemistry, physics, medicine, or a related physical or biological science who, by virtue of special training, is qualified to anticipate, recognize, evaluate, and control environmental and occupational health hazards and the impact of those hazards on the community and workers.



Glossary

In-place management	see <i>interim controls</i> .
Interim controls	a set of measures designed to temporarily reduce human exposure or likely exposure to lead-based paint hazards, including specialized cleaning, repairs, maintenance, painting, temporary containment, ongoing monitoring of lead-based paint hazards or potential hazards, and the establishment and operation of management and resident education programs.
Interior window sill	the portion of the horizontal window ledge that protrudes into the interior of the room, adjacent to the window sash when the window is closed; often called the window stool.
Ion	an atom or group of atoms that has either lost one or more electrons, making it positively charged, or gained one or more electrons, making it negatively charged.
Ionizing radiation	radiation of sufficiently high energy to cause ionization in the medium through which it passes.
Jamb	the side of a window or door opening.
Joist	one of a series of parallel beams used to support a floor (floor joists) or a ceiling (ceiling joists).
Laboratory analysis	a determination of the lead content by atomic absorption spectroscopy, inductively coupled plasma emission spectroscopy, laboratory-based K or L X-ray fluorescence, or an equivalent method.
Latex	a waterborne emulsion paint made with synthetic binders such as 100-percent acrylic, vinyl acrylic, terpolymer, or styrene acrylic; a stable emulsion of polymers and pigment in water.

Inspecting for Lead-based Paint



Lead (inorganic)	an element, represented by the symbol Pb, which means that its atomic structure is permanently arranged and is not changed by chemical reactions. Lead can combine chemically with other atoms or molecules to make new compounds. Lead is considered a heavy metal; "heavy" because lead weighs more than the same volume of water, and "metal," because when it is refined from raw ore into its pure form, lead can be hammered or drawn into shapes.
Lead-accredited laboratory	a laboratory that has been evaluated and received accreditation through EPA's National Lead Laboratory Accreditation Program (NLLAP) to perform lead measurement or analysis, usually over a specified period of time.
Lead-based paint	paint or other surface coatings that contain lead equal to or in excess of 1.0 milligrams per square centimeter or more than 0.5 percent by weight.
Lead-based paint activities	in the case of target housing and child-occupied facilities, inspection, risk assessment, and abatement.
Lead-based paint hazard	any condition that causes exposure to lead from lead-contaminated dust, lead-contaminated soil, or lead-contaminated paint that is deteriorated or present in accessible surfaces, friction surfaces, or impact surfaces that would result in adverse human health effects as identified by the EPA pursuant to TSCA section 403.
Lead-based paint hazard control	activities to control and eliminate lead-based paint hazards, including interim controls, and abatement.
Lead-contaminated dust	surface dust in residential dwellings, or child-occupied facilities, that contains an area or mass concentration of lead at or in excess of levels identified by the EPA pursuant to TSCA section 403.
Lead-contaminated soil	bare soil on residential real property and on the property of a child-occupied facility that contains lead at or in excess of levels identified by the EPA pursuant to TSCA section 403.



Glossary

Lead-based paint free certification	a rental dwelling certified by a certified lead-based paint inspector to contain no lead at or above 1.0 mg/cm ² .
Lead-hazard free dwelling	a dwelling that has been evaluated and contains no lead-based paint and has interior dust and exterior soil lead levels below the applicable federal standards.
Lead-hazard screen	a limited risk assessment activity that involves limited paint and dust sampling as described in Sec. 745.227(c).
Lead-specific detergent	a cleaning agent manufactured specifically for cleaning and removing leaded dust or other lead contamination.
Mean	the arithmetic average of a series of numerical data values; for example, the algebraic sum of the data values divided by the number of data values.
Medical removal	the temporary removal of workers due to elevated blood lead levels as defined in the OSHA Lead Standard (currently 50 µg/dL).
mg	milligram; 1/1,000 of a gram.
Micrograms	one millionth of a gram: µg; the prefix "micro-" means "1/1,000,000 of" (one millionth of). Since there are 453 grams in one pound and 16 ounces in one pound, one gram equals 0.035 ounces. A microgram is equal to about 35/1,000,000,000 (thirty-five billionths) of an ounce.
Mullion	A vertical framing or separating member between adjacent door or window sections.
Multifamily dwelling	a structure that contains more than one separate residential dwelling unit which is used or occupied or intended to be used or occupied, in whole or in part, as the home or residence of one or more persons.
Muntin	a secondary framing member to hold panes within a window, window wall, or glazed door.
Newell post	on a stairway, an end post supporting a run of handrail.



Inspecting for Lead-based Paint

- Paint stabilization** repairing any physical defect in the substrate of a painted surface that is causing paint deterioration, removing loose paint and other material from the surface to be treated, and applying a new protective coating of paint.
- Parting bead** a long narrow strip between the upper and lower sashes in a double-hung window frame, enabling them to slide past each other. Also called parting stop, parting strip.
- Pedestal** a support for a column consisting in classical architecture of a base, dado, or die and a cornice, surbase, or cap; in modern design often a plain unornamented block.
- Performance characteristic sheet (PCS)** a supplemental document developed for each model of portable XRF by EPA and HUD. It provides information on the operating parameters of each XRF instrument. The PCS specifies an inconclusive range, calibration check tolerances, and other instrument-specific information.
- Permanent** an expected design life of at least 20 years.
- Permanently covered soil** soil that has been separated from human contact by the placement of a barrier consisting of solid, relatively impermeable materials, such as pavement or concrete. Grass, mulch, and other landscaping materials are not considered permanent covering.
- Permissible Exposure Limit (PEL)** the maximum worker exposure to lead under the OSHA lead in construction standard. No employee may be exposed to lead at airborne concentrations greater than $50 \mu\text{g}/\text{m}^3$ averaged over an eight-hour period.
- Personal protective equipment (PPE)** equipment for protecting the eyes, face, head, and/or extremities; includes protective clothing, respiratory devices, and protective shields; used when hazards capable of causing bodily injury or impairment are encountered.



Glossary

- Personal samples** (for sampling lead dust) air samples collected from within the breathing zone of a worker, but outside the respirator. The samples are collected with a personal sampling pump, pulling 1 to 4 liters/minute of air.
- Picture molding** any of numerous types of moldings or other such devices so as to support picture hooks at or near the ceiling.
- Pigments** chemicals that have color, or properties which affect color. Usually, a small amount of these chemicals is mixed with another material to color all of the material. Lead carbonate and lead oxide are chemical forms of lead used as pigments.
- Pedestal** a support for a column consisting in classical architecture of a base, dado, or die and a cornice, surbase, or cap; in modern design often a plain unornamented block.
- Play area** an area of frequent soil contact by children of less than six years of age, as indicated by the presence of play equipment (e.g., sandboxes, swing sets, sliding boards, etc.) or toys or other children's possessions, observations of play patterns, or information provided by parents, residents or property owners.
- Plinth block** a wood finish piece placed at the base of a door casing and against which a *baseboard* abuts.
- ppm** "parts per million," meaning the weight of one part per weight of the total amount of material. For example, a lead concentration of one ppm expresses the ratio of one gram of lead dissolved into one million (1,000,000) grams of water.
- Precision** the degree of variation in a series of successive measurements of the same phenomenon. Commonly measured by standard deviation.
- Primary prevention** the process of controlling lead hazards to prevent exposure before a child is poisoned.
- Public Health Department** a state, tribal, county, or municipal public health department or the Indian Health Service.



Inspecting for Lead-based Paint

Public Housing Agency (PHA)	any state, county, municipal, or other governmental entity or public body (or agency or instrumentality thereof) which is authorized to engage or assist in the development or operation of housing for low income families.
Public housing development	a residential property assisted under the United States Housing Act of 1937 (42 U.S.C. 1437 et seq.), but not including housing assisted under Section 8 of the 1937 Act.
Quality assurance (QA)	an integrated system of activities involving planning, quality control, quality assessment, reporting, and quality improvement to ensure that a product or service meets defined standards of quality within a stated level of confidence.
Quality control (QC)	The overall system of technical activities with the purpose of measuring and controlling the quality of a product or service so that it meets the needs of users. The aim is to provide a level of quality that is satisfactory, adequate, dependable, and economical.
Random sample	a sample drawn from a population in a way that allows each member of the population to have an equal chance of being selected. Random sampling is a process used to identify locations for the lead-based inspections in multifamily dwellings.
RCRA	Resource Conservation and Recovery Act of 1976. What we commonly refer to as RCRA is an amendment to the Solid Waste Disposal Act of 1965. RCRA was amended in 1980 and 1984 by the Hazardous and Solid Waste Amendments.
Reevaluation	in lead hazard control work, the combination of a visual assessment and collection of environmental samples performed by a certified risk assessor to determine if a previously implemented lead-based paint hazard control measure is still effective and if the dwelling remains lead-safe.
Regulation or Rule	all or part of any federal statement of general or particular applicability and future effect designed to: (1) implement, interpret, or prescribe law or policy or (2) describe the federal department's organization or its procedure or practice requirements.



Glossary

Representative Sample	a sample of a universe or whole (e.g., painted surface, waste sample pile, lagoon, ground water, or waste stream) which can be expected to exhibit the average properties of the universe or whole.
Residential dwelling	(1) a detached single family dwelling unit, including attached structures such as porches and stoops; or (2) a single family dwelling unit in a structure that contains more than one separate residential dwelling unit which is used or occupied or intended to be used or occupied, in whole or in part, as the home or residence of one or more persons.
Resident	a person who lives in a dwelling.
Riser	in a stairway, the vertical part of a step. In plumbing, a vertical water supply pipe.
Risk assessment	(1) an on-site investigation to determine the existence, nature, severity, and location of lead-based paint hazards, and (2) the provision of a report by the individual or the firm conducting the risk assessment, explaining the results of the investigation and options for reducing lead-based paint hazards.
Room equivalent	an identifiable part of a residence, such as a room, a house exterior, a foyer, staircase, hallway, or an exterior area (exterior areas contain items such as play areas, painted play structures, painted sandboxes, etc.). Closets or other adjoining areas to room equivalents should be designated room equivalents only if large.
Sample site	a specific spot on a surface being tested for lead concentration or contamination.
Sash	the framework into which panes of glass are set.
Screening	the process of testing children to determine if they have elevated blood lead levels.
Secondary prevention	the process of identifying children who have elevated blood lead levels through screening and controlling or eliminating the sources of further exposure.



Inspecting for Lead-based Paint

- Sill** the bottom horizontal part of a window opening.
- Sodium rhodizonate** a chemical used to test a paint sample qualitatively for lead; a positive test is characterized by a pink or red discoloration of the paint film cross section.
- Sodium sulfide** a chemical used to test a paint sample qualitatively for lead; typical concentrations are from 6 to 10%. A positive test is characterized by a gray or black discoloration of the paint film cross section.
- Soffit** the underside of a horizontal surface which projects beyond a wall line, such as an overhanging roof.
- Solid waste** as defined in RCRA, any garbage, refuse, sludge from a waste treatment plant, water supply treatment plant, or air pollution control facility and other discarded material, resulting from industrial, commercial, mining, and agricultural operations, and from community activities, but does not include solid or dissolved material in domestic sewage, or solid or dissolved materials in irrigation return flows or industrial discharges which are point sources subject to permits under the Clean Water Act, or special nuclear or by-product material as defined by the Atomic Energy Act of 1954.
- Spectrum analyzer** a type of XRF analyzer which provides the operator with a plot of the energy and intensity of both "K" and "L" X rays, as well as a calculated lead concentration.
- XRF**
- Spiked sample** a sample prepared by adding a known mass of the target analyte (e.g., leaded dust) to a specific amount of matrix sample (e.g., one dust wipe) for which an independent estimate of the target analyte concentration is available.
- Standard** used in two ways in this manual: (a) levels established by law or regulation, such as 1.0 mg/cm²; (b) materials to which known quantities of lead have been applied; used to evaluate the accuracy and performance of the XRF analyzer, usually called Standard Reference Materials.



Glossary

- Standard deviation** a measure of the precision of the readings, defined as the root-mean-square deviation from the mean. The smaller the standard deviation, the more precise the analysis, and the less variation there is when an analysis is repeated. Scientific calculators generally have a standard deviation key.
- Standard treatments** a series of hazard reduction measures designed to reduce all lead-based paint hazards in a dwelling unit without the benefit of a risk assessment or other evaluation.
- Stile** one of the upright structural members of a frame, as at the outer edge of a door or a window sash.
- Stringer** a longitudinal inclined beam supporting a stairway.
- Subsample** a representative portion of a sample. A subsample may be either a field sample or a laboratory sample. A subsample is often combined with other subsamples to produce a composite sample.
- Substrate** a surface upon which paint or varnish has been or may be applied. Examples included in the HUD *Guidelines* are: wood, plaster, metal, brick, drywall, and concrete. Substrates can contain lead absorbed from paint or from other sources.
- Substrate correction** reducing the apparent lead reading by the level attributable to the substrate. The substrate correction level is determined by taking a total of six readings on two different locations of each bare substrate. The *XRF Performance Characteristic Sheet* must be consulted to determine if substrate correction is needed for the analyzer being used.
- Substrate effect** the returning of backscattered radiation from the paint, substrate or underlying material to the XRF analyzer. This radiation when counted as lead X rays by an XRF contributes to the bias. The inspector may have to compensate for this effect when using some XRF analyzers.



Inspecting for Lead-based Paint

Target housing	any housing constructed prior to 1978, except housing for the elderly or persons with disabilities (unless any one or more children age 6 years or under resides or is expected to reside in such housing for the elderly or persons with disabilities) or any 0-bedroom dwelling.
Tenant	the individual named as the lessee in a lease, rental agreement or occupancy agreement for a dwelling unit.
Tertiary prevention	providing medical treatment to children with elevated blood lead levels to prevent more serious injury or death.
Testing combination	a unique surface to be tested that is characterized by the room equivalent, component, and substrate.
Threshold	a strip of metal or wood used under a door to cover the joint between differing flooring materials on each side of the door and to help seal the gap under the door.
Toxicity characteristic leachate procedure (TCLP)	one of the tests for the determination of whether a solid waste is classified as a hazardous substance.
Transom	an openable window over a doorway.
Tread	the horizontal part of a stair step.
Trisodium phosphate (TSP) detergent	a detergent that contains trisodium phosphate.
Trough	see <i>window trough</i>
µg	microgram; the prefix micro- means 1/1,000,000 (or one millionth); a microgram is 1/1,000,000 of a gram and 1/1,000 of a milligram; equal to about 35/1,000,000,000 (35 billionths) of an ounce.
Visual inspection	the visual examination of a residential dwelling or a child-occupied facility following an abatement to determine whether or not the abatement has been successfully completed.



Glossary

- Visual examination** the examination of a residential dwelling or a child occupied facility to determine the existence of deteriorated lead-based paint or other potential sources of lead-based paint hazards.
- Window casing** see *casing*
- Window trough** for a typical double-hung window, the portion of the exterior window sill between the interior window sill (or stool) and the frame of the storm window. If there is no storm window, the window trough is the area that receives both the upper and lower window sashes when both are lowered. Sometimes inaccurately called the window "well."
- Window well** the space that provides exterior access and/or light to a window that is below grade, i.e., below the level of the surrounding earth or pavement.
- Worksite** an interior or exterior area where lead-based paint hazard reduction activity takes place. There may be more than one worksite in a dwelling unit or at a residential property.
- X rays** electromagnetic radiation of shorter wavelength than ultraviolet radiation and longer wavelength than gamma radiation. Atoms of all the elements emit a characteristic *X-ray spectrum* when they are bombarded by electrons.
- X-ray fluorescence** the emission of X rays from excited atoms produced by the impact of high-energy electrons, other particles, or primary beam of other X rays.
- X-ray fluorescence analyzer (XRF)** an instrument which estimates lead concentration in milligrams per square centimeter (mg/cm^2) using the principal of X-ray fluorescence.
- Zero-bedroom dwelling** any residential dwelling in which the living areas are not separated from the sleeping area. The term includes efficiencies, studio apartments, dormitory or single room occupancy housing, military barracks, and rentals of individual rooms in residential dwellings.



Credits

The definitions used in this glossary came from several sources including:

Brooks, H. *Illustrated Encyclopedic Dictionary of Building and Construction Terms*, Prentice-Hall, Inc., Englewood Cliffs, N.J., 1977.

Concise Science Dictionary, Oxford University Press, Oxford, 1984.

Dictionary of Architecture and Construction, 2nd Edition, C. M. Harris, Ed., McGraw-Hill, Inc., New York, 1993.

EPA 1996. *Lead; Requirements for Lead-based Paint Activities in Target Housing and Child-occupied Facilities; Final Rule*; 40 CFR Part 745.

HUD 1999. *Requirements for Notification, Evaluation and Reduction of Lead-Based Paint Hazards in Housing Receiving Federal Assistance and Federally Owned residential Property Being Sold*; 24 CFR Part 35.

HUD 1995. *Guidelines for the Evaluation of Lead-based Paint Hazards in Housing*, rev. 1997.

Greenville Technical College

Lead Inspector Training Review Questions

Chapter 1 - Course Overview

1. What should this course teach a lead inspector to do?
2. What does LBP mean?
3. What is Title X?
4. As of March 2000, lead inspections in _____ and _____ must be performed by certified lead inspectors.
5. Give three reasons we find higher blood lead levels among lower income children.
6. Explain the "CDC level of concern."
7. Define lead based paint.
8. Define lead based paint hazards and explain the definitions included in Title X relating to these hazards.

Greenville Technical College

Lead Inspector Training Review Questions

9. What is a lead based paint inspection?
10. Much of this course is based on the _____

11. What is the LBPPPA?
12. What does "Pb" mean?

Greenville Technical College

Lead Inspector Training Review Questions

Chapter 2 - Background Information for Lead Inspectors

1. What is lead?

2. How were lead compounds such as white lead and lead chromate commonly used?

3. List three main reasons lead was used in paint.

4. Explain why lead was often used in high moisture areas.

5. What limit was adopted in 1978 as part of the LBPPA for lead in residential paint?

6. What are the major sources of lead hazards for adults? for children?

7. Name four major sources for childhood lead poisoning.

8. How do children usually ingest lead?

9. What are some sources of contamination for lead in surface dust and soil?

Greenville Technical College

Lead Inspector Training Review Questions

10. What is the primary source for lead in drinking water?

11. What caused a decline in airborne lead in the last twenty years?

12. List several other potential sources of lead exposure.

Greenville Technical College

Lead Inspector Training Review Questions

Chapter 3 – Health Effects of Lead Exposure

1. Who is most vulnerable to lead poisoning?
2. Name three systems of your body that can be most affected by lead poisoning.
3. How did the NHANES surveys evaluate lead exposure in children? What were the results of these surveys?
4. What is the current CDC level of concern for blood lead levels in children and pregnant women?
5. Explain the difference between the common route of lead exposure for children and for adults.
6. What should lead inspectors do to prevent lead exposure?
7. Where is lead stored in the body?

Greenville Technical College

Lead Inspector Training Review Questions

Chapter 4– Regulatory Background

1. What law was passed in 1992 that switched the focus to lead based paint *hazards*?

2. What is TSCA and how was it amended by Title X?

3. What lead regulations are found at 24 CFR Part 35?

4. What methods of paint removal are prohibited by HUD?

5. What are the “de minimis” levels that require “safe work practices” according to HUD regulations?

6. List three examples of “safe work practices.”

7. What is the construction date for “target housing?”

8. Discuss the disclosure requirements that became effective in 1996?

Greenville Technical College

Lead Inspector Training Review Questions

9. How do EPA and HUD define lead paint in their determination of whether or not housing is “lead-based paint free?”

10. What is a child occupied facility?

11. When does the EPA require certified lead firms? Certified lead inspectors? Recertification?

12. Are the “documented methodologies” in the HUD Guidelines for the Evaluation and Control of Lead-based Paint Hazards in Housing enforceable by law?

13. Federal regulations concerning lead are sometimes superseded by _____.

14. What is the “PRE” Rule and when did it go into effect?

15. What is the OSHA PEL for lead? What is the action level?

16. When does OSHA require medical removal for lead workers?

17. What must be done if an employee’s blood lead level exceeds the medical removal protection level?

Greenville Technical College

Lead Inspector Training Review Questions

18. Where do you find the OSHA regulations for Lead in Construction?
19. Where do you find the OSHA regulations for Respiratory Protection?
20. Which federal law governs the disposal of lead waste?
21. Explain how lead is tested in waste and define the level of lead determined to be "hazardous waste" (included in the class discussion – not in text).
22. What minimum level of contamination is established as a goal for 90% of monitored household drinking water taps in the National Primary Drinking Water standard?
23. How does 40 CFR Part 745 define inspections and risk assessments? What are the major differences?

Greenville Technical College

Lead Inspector Training Review Questions

Chapter 5 - Theory and Use of X-Ray Fluorescence Analyzers

1. What does XRF mean?
2. Explain the two basic types of error that can be encountered when testing LBP.
3. What are the two types of portable XRF analyzers?
4. What two kinds of radiation are emitted by an XRF analyzer?
5. What is a *characteristic X ray*?
6. What is the main difference between a direct reader and a spectrum analyzer?
7. What is a "half-life" and how does it affect the cost of operating an XRF?
8. What is ionizing radiation?
9. List eight rules of operation for safe use of an XRF.

Greenville Technical College

Lead Inspector Training Review Questions

10. What does "mrem" mean?

11. How does the example of a lead inspector's radiation exposure given in your text compare to the NRC whole body limit of 5 rem per year?

12. Explain ALARA.

13. What are the three major considerations for radiation safety?

14. What is used to monitor radiation on an inspector?

15. What is a leak test and how often should it be performed?

16. Portable XRF analyzers operate from a _____ and come with a _____. Therefore, in order to operate the machine, you must first remember to do what?

17. What must the inspector do if the XRF cannot perform an accurate measurement?

Greenville Technical College

Lead Inspector Training Review Questions

18. Name four factors that affect the amount of backscattering interference and substrate bias exhibited by XRF analyzers.
19. What is a Performance Characteristic Sheet?
20. When choosing a location for performing a substrate correction, the initial XRF reading should be less than _____.
21. Explain the difference between accuracy, precision and bias.
22. What is an SRM? Which film is closest to the federal standard for LBP?
23. Review the procedure for performing a calibration check and discuss how often this should be performed.
24. Explain the training, transporting and recordkeeping requirements for XRF use.

Greenville Technical College

Lead Inspector Training Review Questions

Chapter 6 - Liability and Insurance Issues

1. Name three sources of liability for the lead inspector.
2. What can happen to a lead inspector who fails to adhere to applicable statutes and regulations?
3. List some possible damages related to tort or contract liability for lead inspectors.
4. What does indemnification mean?
5. What is "Tort Law" and what four elements must be present must be proven in tort liability claims?
6. What is the difference between negligence and vicarious liability?
7. List some general guidelines the lead inspector can follow to avoid contract liabilities.
8. When should the inspector report that a property is "lead free?"

Greenville Technical College

Lead Inspector Training Review Questions

9. What is the difference between E&O insurance and general liability insurance?

10. What is the difference between a claims made insurance policy and an occurrence insurance policy?

YOU BE THE JUDGE:

If a homeowner asks you to perform a limited lead inspection with minimum sampling to reduce costs, would you be responsible for informing the client about deficiencies in their proposed testing plan?

Who should inform the homeowner about the advantages of having a risk assessment performed instead of an inspection?

If a tenant hires you to do a lead inspection and tells you their child has an elevated blood lead level, should you inform them that their landlord is responsible for paying for lead inspections and abating hazards in properties with EBL children?

Greenville Technical College

Lead Inspector Training Review Questions

Chapter 7 – Lead-based Paint Testing Operations

25. Who should conduct an EBL investigation?
26. Name some things you should discuss with the client before you perform a lead inspection.
27. List nine responsibilities of the lead inspector.
28. Define a “testing combination.”
29. List six common types of substrates.
30. A “surface by surface” investigation means you should test surfaces that are representative of each _____ located in every _____.

Greenville Technical College

Lead Inspector Training Review Questions

31. Which components may be grouped to form a testing combination?

32. What is meant by the term “multi-family housing”?

33. List some typical parts of a stairwell

34. List some typical parts of a window.

35. Where should you record your information when you are conducting an initial inventory of painted surfaces?

36. Explain the recommended procedure for labeling the sides of a dwelling, numbering room equivalents, and numbering components

37. Review the calibration drift check procedure described in Chapter 5.

Greenville Technical College

Lead Inspector Training Review Questions

11. How many test locations should be selected for each testing combination?

12. Describe the appropriate sampling strategy for testing walls.

13. What special testing strategy is allowed for varnished, stained or similar clear-coated floors?

14. HUD guidelines require testing each component with a different substrate in each _____
_____.

15. Explain the provisions for abbreviated testing.

16. Summarize the substrate correction procedure.

Greenville Technical College

Lead Inspector Training Review Questions

Chapter 8 – Visual Inspections

1. What are the three responsibilities of the inspector in ensuring the effectiveness of cleanup activities?
2. List three problem areas typically encountered in visual inspections.
3. When should the inspector perform the visual inspection of components that are scheduled for paint removal and repainting?
4. How deep should the inspector look for soil contamination?

Greenville Technical College

Lead Inspector Training Review Questions

Chapter 9 – Dust Sampling for Lead Contamination

1. What is the difference between concentration and loading?

2. Give three pass/fail criteria for wipe sampling: EPA interim guidance, HUD, and EPA current clearance levels.

3. Describe the specifications for disposable wipes to be used for clearance dust sampling.

4. Describe the procedure for single-surface clearance wipe sampling on floors.

5. How must this procedure be modified if you are performing composite wipe sampling?

6. What procedures can you use to check the accuracy of your wipe sampling results?

Greenville Technical College

Lead Inspector Training Review Questions

7. How many clearance dust samples do you need to take for interior treatment with no containment?
With containment? Exterior treatments?

8. What is the formula for determining the area of a wipe sample in square feet if you measure your sampling area (such as a window sill) in inches?

9. What should you do if a wipe sample fails to pass the clearance criteria?

Greenville Technical College

Lead Inspector Training Review Questions

Chapter 10 – Soil Sampling for Lead Contamination

1. If clearance examinations do not require soil sampling, why does the text include a discussion of pre- and post-abatement soil sampling?
2. Describe soil sampling procedures.
3. What are some typical locations for soil samples?
4. What are the current levels of concern for residential soil and how do these levels compare to the pre-2001 soil concentration levels contained in HUD and EPA guidance documents?

Greenville Technical College

Lead Inspector Training Review Questions

Chapter 12 – Field Trip (no review questions)

Chapter 13 – Data Evaluation and Report Preparation

1. List some common errors found in lead inspection reports.
2. What information should be included in the XRF data evaluation for single-family housing?
Multifamily housing?
3. What is meant by the term “abbreviated testing”?
4. Name four sections that should be included in all inspection reports.
5. How long should inspection reports be kept?